

The IT 0-10 240/100-277/N series is a 240W, constant-current and IP20 rated LED driver that operates from 90-305Vac input with excellent power factor. Created for area lighting application, this family provides an auxiliary voltage and dim-to-off functionality for powering low voltage sensors. The dimming control supports 0(1)-10V, PWM dimming, resistor dimming, and AstroDIM dimming. The high efficiency of these drivers and compact metal case enables them to run cooler, significantly improving reliability and extending product life. To ensure trouble-free operation, protection is provided against input surge, output over voltage, short circuit, and over temperature.



Features

- Non-Isolated Design with Low Residual Output Voltage < 2 kV
- No Afterglow on Specific Models
- Ultra High Efficiency (Up to 97%)
- Full Power at Wide Output Current Range (Constant Power)
- Adjustable Output Current (AOC) with T4T(Tuner4TRONIC)
- Isolated 0(1)-10V/PWM/Resistor/AstroDIM(Timer) Dimmable
- Dim-to-Off with Standby Power ≤ 0.5 W
- Adjustable Dimming Curve
- Always-on Auxiliary Power: 12Vdc, 200mA
- End-of-Life Indicator
- Override Dimming
- Constant Lumen
- Additional port (BM+) for current setting via external Dip Switch
- Additional port (OP+) for external Light Sensor on Specific Models
- Input Surge Protection: DM 6kV, CM 6kV
- All-Around Protection: OTP, OVP, SCP
- 5 Years Warranty

Application

- IP20 Design and Suitable for Outdoor Applications in Luminaires with IP>54
- Suitable for Luminaires with Protection Class I
- Suitable for Built-in Use

Models

Adjustable Output Current Range(mA)	Full Power Current Range (mA) ⁽¹⁾	Default Output Current (mA)	Nominal Output Voltage Range(Vdc)	Maximum Output Power(W) ⁽²⁾	Typical Efficiency ⁽³⁾	Power Factor λ	Product Name ⁽⁴⁾⁽⁵⁾
80-1100	800-1100	1000	180-300	240	97.0%	0.97	IT 0-10 240/100-277/1A1/N y

- Notes:** (1) Output current range with constant power at 240W.
 (2) Output power shall not exceed the rated maximum.
 (3) Measured at 100% load and 230Vac input (see below "General Specifications" for details).
 (4) Certified input voltage range: 100-277Vac.
 (5) Definition of y (see below "Product Version Description" for details).

Product Version Description

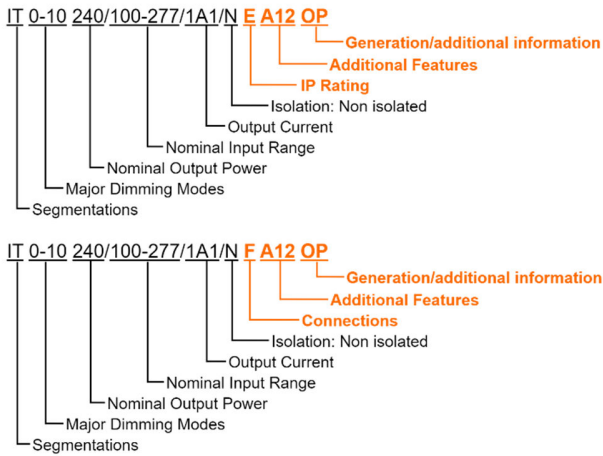

Markers	Value	Definition	Notes
IP rating	Blank	IP20	Indoor
	E	IP20	Outdoor
Connections	Blank	Push Terminals	
	F	Flying Leads	
Additional Features	A12	Aux-12V	
Generation/additional information	Blank	First generation	
	OP	Optical Sensor	Light Sensor

Input Specifications

Parameter	Min.	Typ.	Max.	Notes
Input Voltage AC	90 Vac	-	305 Vac	
Input Voltage DC	127 Vdc	-	300 Vdc	
Mains Frequency	47 Hz	-	63 Hz	
Leakage Current	-	-	0.75 MIU	UL 8750; 277Vac/60Hz
	-	-	0.70 mA	IEC 60598-1; 277ac/60Hz
Nominal Input Current	-	-	2.35 A	Measured at 100% load and 120 Vac input.
	-	-	1.21 A	Measured at 100% load and 230 Vac input.
Power Factor λ	0.9	-	-	At 100-277Vac, 50-60Hz, 70%-100% Load (168-240W)
Total Harmonic Distortion	-	-	20%	
Power Factor λ Extended Range	0.95	0.97	-	At 220-240Vac, 50-60Hz, 100% load
Total Harmonic Distortion Extended Range	-	8%	10%	

Output Specifications

Parameter	Min.	Typ.	Max.	Notes
Programmable Output Current	80 mA	-	1100 mA	
Nominal Output Voltage	180 V	-	300 V	
Output Current Tolerance	-5%	-	+5%	At 100% load condition
Total Output Current Ripple HF	-	-	10%Iomax	At 100% load condition. 20 MHz BW (pk-avg)
Output Current Ripple LF	-	5%Iomax	-	At 100% load condition, <200 Hz (pk-avg)
P_{stLM}	-	-	1.0	
SVM	-	-	0.4	
Startup Overshoot Current	-	-	10%Iomax	At 100% load condition

Output Specifications (Continued)

Parameter	Min.	Typ.	Max.	Notes
U _{out}	-	-	350 V	
Line Regulation	-	-	± 3.0%	Measured at 100% load
Load Regulation	-	-	± 5.0%	
Turn-on Delay Time	-	-	1.0 s	Measured at 120-277Vac input, 70%-100% load
Temperature Coefficient	-	0.03%/°C	-	Case temperature = 0°C ~T _c max
Auxiliary Output Voltage	10.8 V	12 V	13.2 V	Return terminal is "Dim--"
Auxiliary Output Source Current	0 mA	-	200 mA	

General Specifications

Parameter	Min.	Typ.	Max.	Notes
Efficiency at 120Vac Input I _o = 800 mA I _o =1100 mA	93.0% 92.0%	95.0% 94.0%	- -	Measured at 100% load and Steady-state temperature in 25°C ambient; (Efficiency will be about 2.0% lower if measured immediately after startup.)
Efficiency at 230Vac Input I _o = 800 mA I _o =1100 mA	95.0% 94.0%	97.0% 96.0%	- -	Measured at 100% load and Steady-state temperature in 25°C ambient; (Efficiency will be about 2.0% lower if measured immediately after startup.)
Efficiency at 277Vac Input I _o = 800 mA I _o =1100 mA	95.0% 94.0%	97.0% 96.0%	- -	Measured at 100% load and Steady-state temperature in 25°C ambient; (Efficiency will be about 2.0% lower if measured immediately after startup.)
Networked Standby Power	-	-	0.5 W	Measured at 230Vac/50Hz; Dimming off
MTBF	-	307,000 Hours	-	Measured at 230Vac input, 80%Load and 25°C ambient temperature (MIL-HDBK-217F)
Surge Protection (L - N)	6KV	-	-	2ohm, IEC 61000-4-5
Surge Protection (L/N - E)	6KV	-	-	12ohm, IEC 61000-4-5
Operating Case Temperature for Safety T _{c_s}	-40°C	-	+90°C	
Operating Case Temperature for Warranty T _{c_w}	-40°C	-	+85°C	Case temperature for 5 years warranty Humidity: 10% RH to 95% RH; No Condensation
Lifetime	-	103,000 Hours	-	Measured at 230Vac input, 80%load and 75°C case temperature; See lifetime vs. tc curve for the details
Ambient Temperature	-40°C	-	+60°C	Measured at 230Vac input, 100% load
Permitted rel. Humidity During Operation	5%	-	95%	No Condensation
Temperature at Storage	-40°C	-	+85°C	Humidity: 5%RH to 95%RH, No Condensation
Mains Switching Cycles	100,000	-	-	
IP Rating	IP20			
Dimensions (L × W ×H)	5.34 x 2.17 x 1.30 inches 135.6 x 55 x 33 mm			Mounting distance 5.03 inches 127.8 mm
Net Weight	-	415 g	-	

Inrush Current Waveform

Input AC Voltage	Inrush Current I_{peak}	Inrush Current Width t_{width} (@ 50% I_{peak})	The Number of LED Driver can be Configured (MCB)							
			B10A	B16A	B20A	B25A	C10A	C16A	C20A	C25A
120Vac	35.8 A	240 μ s	2	4	5	7	3	5	6	8
230Vac	77.5 A	220 μ s	4	7	9	11	6	10	12	15
277Vac	90.5 A	224 μ s	4	7	8	11	7	11	14	18

Notes: The maximum number of units per circuit breaker is an indicative value.

Dimming Specifications

Parameter	Min.	Typ.	Max.	Notes	
Absolute Maximum Voltage on the Vdim (+) Pin	-20 V	-	20 V		
Source Current on Vdim (+)Pin	95 μ A	100 μ A	105 μ A	Vdim(+) = 0 V	
Dimming Output Range	10%loset	-	loset	800 mA \leq loaset \leq 1100 mA	
	80 mA	-	loset	80 mA \leq loaset < 800 mA	
AstroDIM (Timer)	10%	-	100%		
Dimming for 0(1)-10V	0 V	-	10 V	Dimming mode set to 0(1)-10V in T4T.	
Dim off Voltage	0.50 V	0.75 V	0.90 V		
Dim on Voltage	0.75 V	1.0 V	1.15 V		
Hysteresis	-	0.2 V	-		
Recommended Dimming for 0(1)-10V	1 V	-	9 V	Default 0-10V dimming mode with positive logic.	
Dimming Curve Adjustable	0 V	-	10 V	Dimming mode set to Adjustable Dimming Curve in T4T.	
PWM_in High Level	3 V	-	10 V	Dimming mode set to PWM Dimming in T4T.	
PWM_in Low Level	-0.3 V	-	0.6 V		
PWM_in Frequency	200 Hz	-	3 KHz		
PWM_in Duty Cycle	1%	-	99%		
PWM Dimming off (Positive Logic)	3%	5%	8%		
PWM Dimming on (Positive Logic)	5%	7%	10%		
PWM Dimming off (Negative Logic)	92%	95%	97%		
PWM Dimming on (Negative Logic)	90%	93%	95%		
Hysteresis	-	2%	-		
Dip Switch Port (BM+)	Output Current Setting Range	80 mA	-	1100 mA	Output current can be set in T4T.
	Current 1	-	600 mA	-	Resistor value between BM+ and Dim- 470 Ohm
	Current 2	-	800 mA	-	Resistor value between BM+ and Dim- 1k Ohm
	Current 3	-	1000 mA	-	Resistor value between BM+ and Dim- 3.3k Ohm
Light Sensor Port (OP+)	OFF/Low signal	0 V	1.0 V	1.2 V	Default: 5S action; Time / Voltage / Dimming level can be set in T4T
	ON/High signal	2.5 V	3.5 V	10.0 V	

Certificates & Standards

Safety Category	Standard
UL/CUL	UL 8750, CAN/CSA-C22.2 No. 250.13
FCC Part 15	ANSI C63.4 Class B
	This device complies with Part 15 of the FCC Rules. Operation is subject to the following two conditions: [1] this device may not cause harmful interference, and [2] this device must accept any interference received, including interference that may cause undesired Operation.
ENEC	EN 61347-1, EN 61347-2-13, EN IEC 62384
CE	EN 61347-1, EN 61347-2-13, EN IEC 55015, EN 61547, EN IEC 61000-3-2, EN 61000-3-3
CB	IEC 61347-1, IEC 61347-2-13
CCC	GB/T 19510.1, GB/T 19510.213, GB/T 17743, GB 17625.1
KS	KS C 7655

Note: (1) This LED driver meets the EMI specifications above, but EMI performance of a luminaire that contains it depends also on the other devices connected to the driver and on the fixture itself.

Isolation Levels

	Input	Output	Dimming	Aux	Housing
Input	N/A	Non	Reinforced	Reinforced	Basic
Output	Non	N/A	Reinforced	Reinforced	Basic
Dimming	Reinforced	Reinforced	N/A	Non	Basic
Aux	Reinforced	Reinforced	Non	N/A	Basic
Housing	Basic	Basic	Basic	Basic	N/A

Note: The LED module must be insulated at least for 2500V.

Operating Window

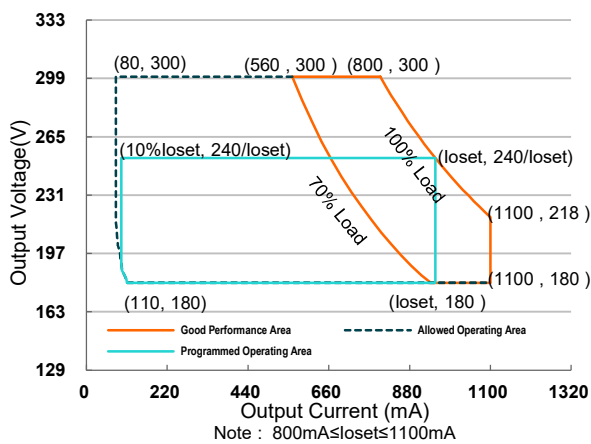

Derating

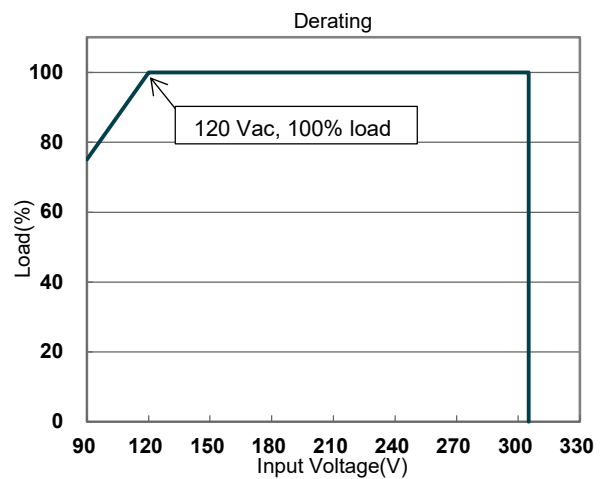

Lifetime vs. Case Temperature

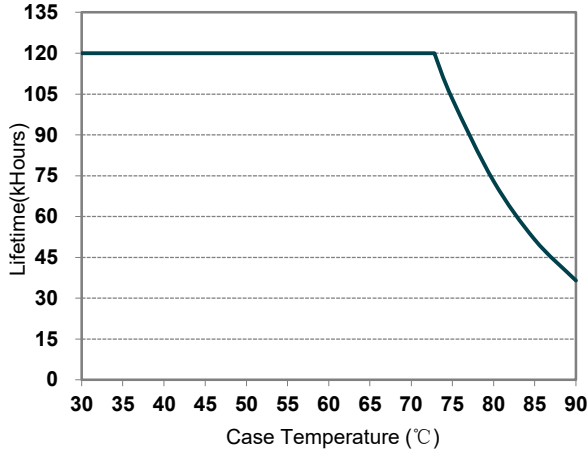

Efficiency vs. Load@277Vac

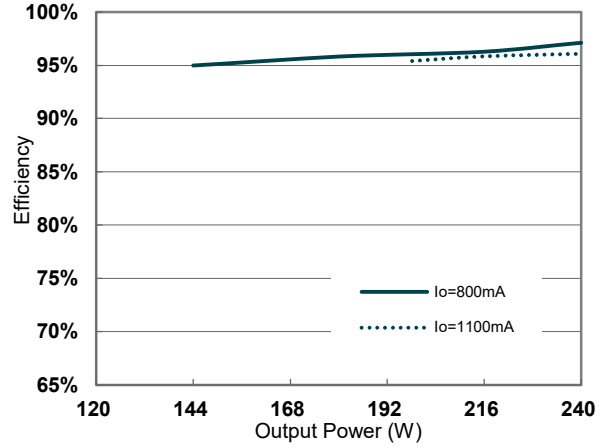

Efficiency vs. Load@120Vac

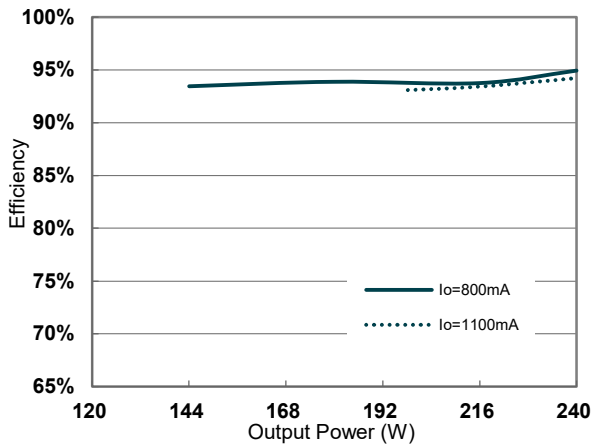

Power Factor

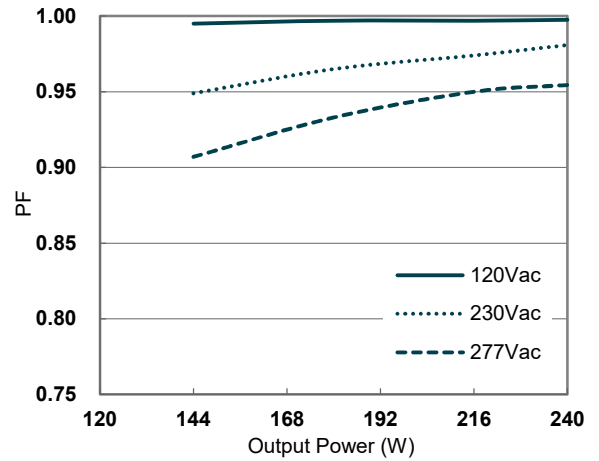

Efficiency vs. Load@230Vac

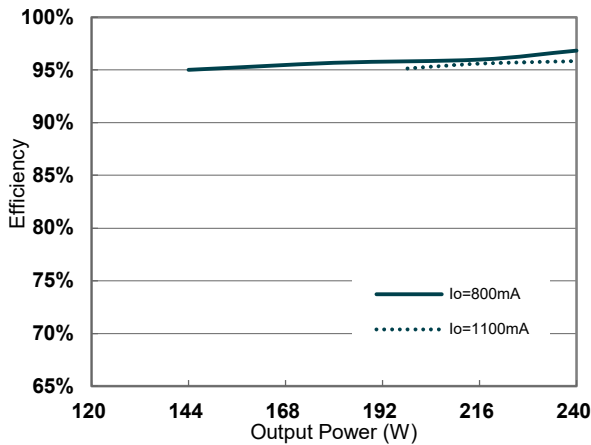

Total Harmonic Distortion

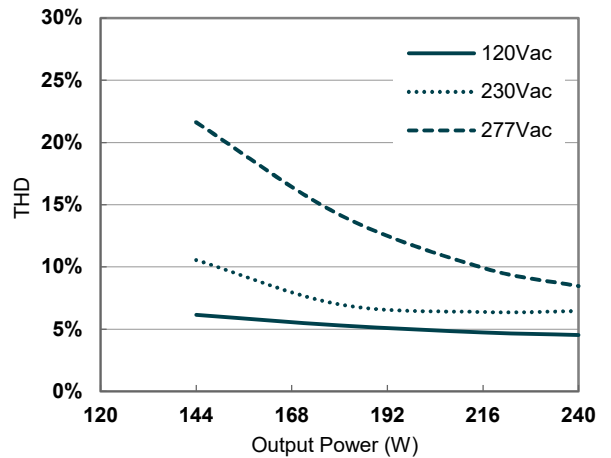

Protection Functions

Over Temperature Protection(OTP)

Protection based on safety: decreases output current if maximum internal temperature is reached, returning to normal value after over temperature is removed.

When output current reaches 20%, switch-off until over temperature is removed.

Driver Guard

Default setting: disabled.

Protection based on lifetime: It can be activated via T4T. Set a lower internal temperature threshold (Thermal Settings: reduce the temperature threshold by 5°C, 10°C, 15°C or 20°C) to activate the over temperature protection.

Dimming

Adjustable Dimming Curve

0-10V curve can be set as corresponding dimming voltage by T4T. Take the 0-10V positive logic dimming mode as an example, the recommended implementation of the dimming control is provided below:

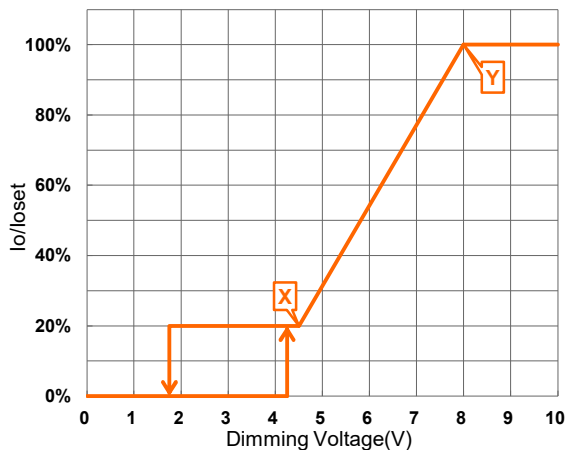

Notes:

1. Do NOT connect Dim- to the output V- or V+, otherwise the driver will not work properly.
2. The dimmer can also be replaced by an active 0-10V voltage source signal or passive components like zener.
3. When dimming voltage X point is set to be smaller than Y point, the dimming curve is positive logic; conversely, when X point is set to be bigger than Y point, the dimming curve is negative logic.
4. For best dimming accuracy, the difference between X point and Y point is advised not less than 4V.

0(1)-10V Dimming

The recommended implementation of the dimming control is provided below:

The driver is protected against temporary overheating by automatically reduction of the output current.

Over Voltage Protection(OVP)

Limits output voltage at no load and in case the normal voltage limit fails.

Short Circuit Protection(SCP)

Auto Recovery. No damage will occur when any output is short circuited. The output shall return to normal when the fault condition is removed.

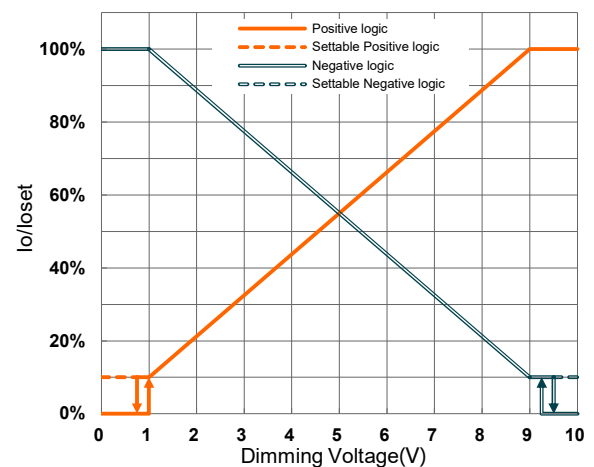

Notes:

1. Do NOT connect Dim- to the output V- or V+, otherwise the driver will not work properly.
2. The dimmer can also be replaced by an active 1-10V voltage source signal or passive components like zener.

PWM Dimming

The recommended implementation of the dimming control is provided below:

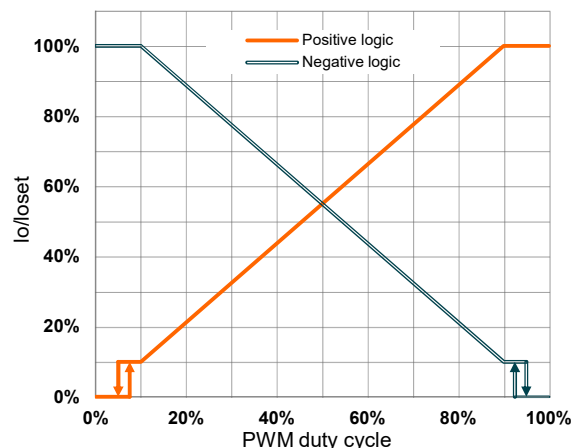

Notes:

1. Do NOT connect Dim- to the output V- or V+, otherwise the driver will not work properly.
2. When PWM negative logic dimming mode and Dim+ is open, the driver will dim to off and be standby.

Resistor Dimming

The recommended implementation of the dimming control is provided below:

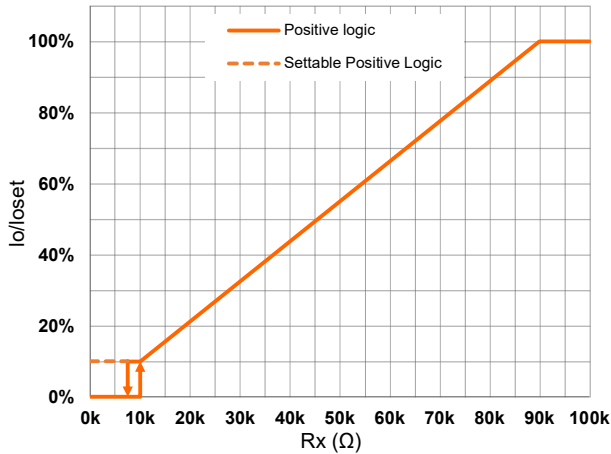

Notes:

1. Do NOT connect Dim- to the output V- or V+, otherwise the driver will not work properly.

AstroDIM(Timer)

AstroDIM (Timer) includes 2 kinds of modes, they are Astro Based and Time Based.

- **Astro Based:** The benchmark for the dimming profile is based on the average midnight each year, which is precisely calculated using

theoretical sunrise and sunset times. The LED driver strictly adheres to daily power-on and power-off times to execute the corresponding dimming configuration file. Furthermore, the adjustment of the dimming schedule is dynamic, automatically adapting according to the actual length of the night to ensure that the lighting effect aligns with nighttime environmental needs.

- **Time Based:** The dimming profile defined in the reference schedule is referenced to the switch-on time of the LED driver.
- **Override Dimming:** When the integrated "AstroDIM(Timer)+Override" is enabled, it is possible to override the dimming mode from 'AstroDIM' into 'Adjustable Dimming Curve' mode by applying a voltage of 1(0)-10V between DIM+ and DIM-. Once a voltage ≤ 10.5 Vdc is detected the output current will coincide with the dimming voltage. By opening the DIM+ and DIM- circuitry, the LED driver will switch again to AstroDIM mode. During override, our product continues to count while the AstroDIM is being overridden. Once the override is removed, the output current returns to the same point in its AstroDIM cycle.

Constant Lumen

Constant lumen function may be used to maintain constant light output over the life of the LEDs by driving them at a reduced current when new, then gradually increasing the drive current over time to counteract LED lumen degradation. This function is disabled by default.

End Of Life

End-of-Life (EOL) is providing a visual notification to a user that the LED module has reached the end of manufacturer-specified life and that the replacement is recommended. Once active, an indication is given at each power-up of the driver, which the driver indicates this through a lower light output (minimum output current level) during the first 10 minutes before normal operation is continue.

Programming Connection Diagram

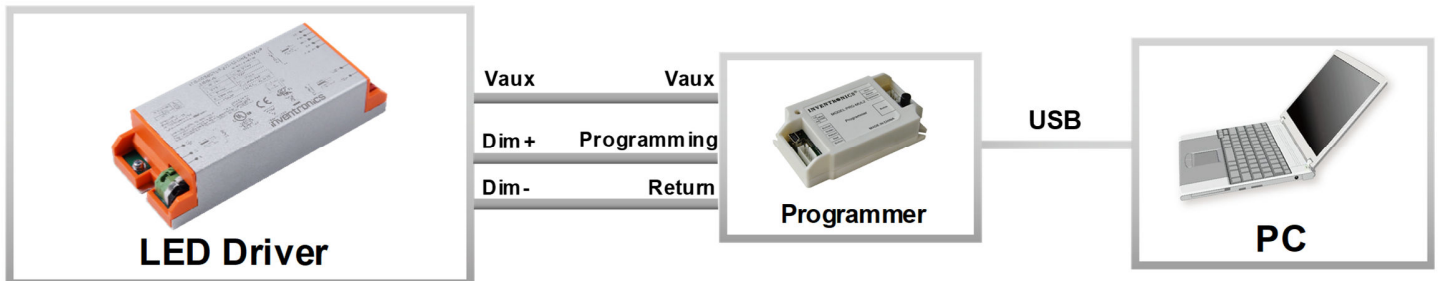

- Note:** (1) The driver does not need to be powered on during the programming process.
 (2) Please refer to [PRG-MUL2](#) (Programmer) datasheet for details.
 (3) Supports [T4T](#) functionality.

Mechanical Outline

IT 0-10 240/100-277/1A1/N E A12 OP

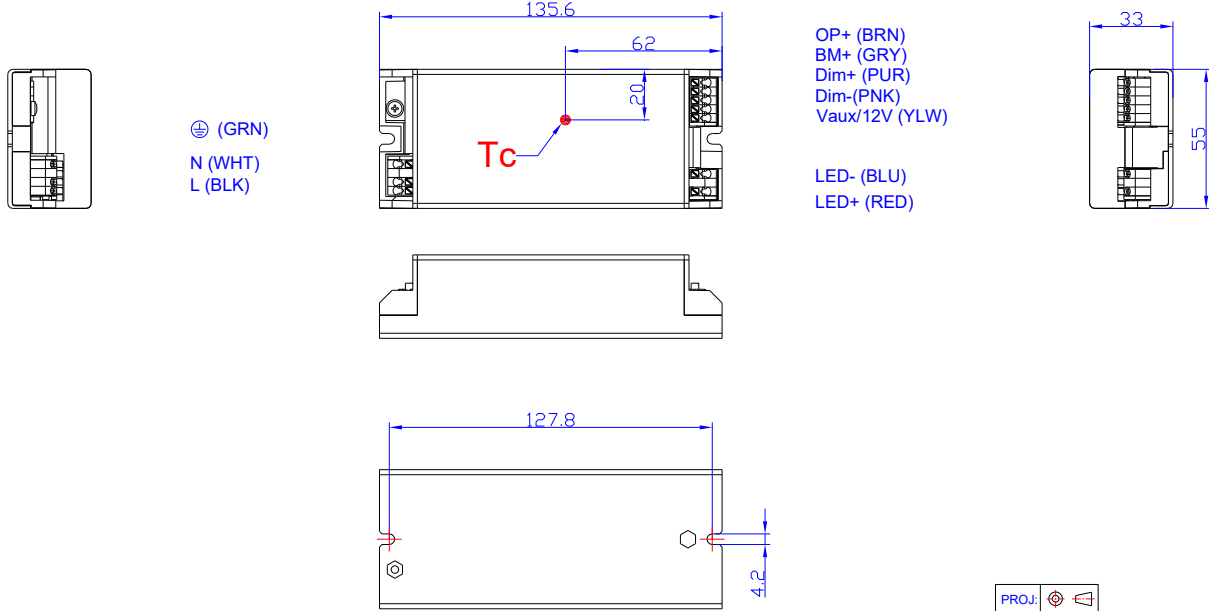

Unspecified tolerance: ±1

IT 0-10 240/100-277/1A1/N F A12 OP

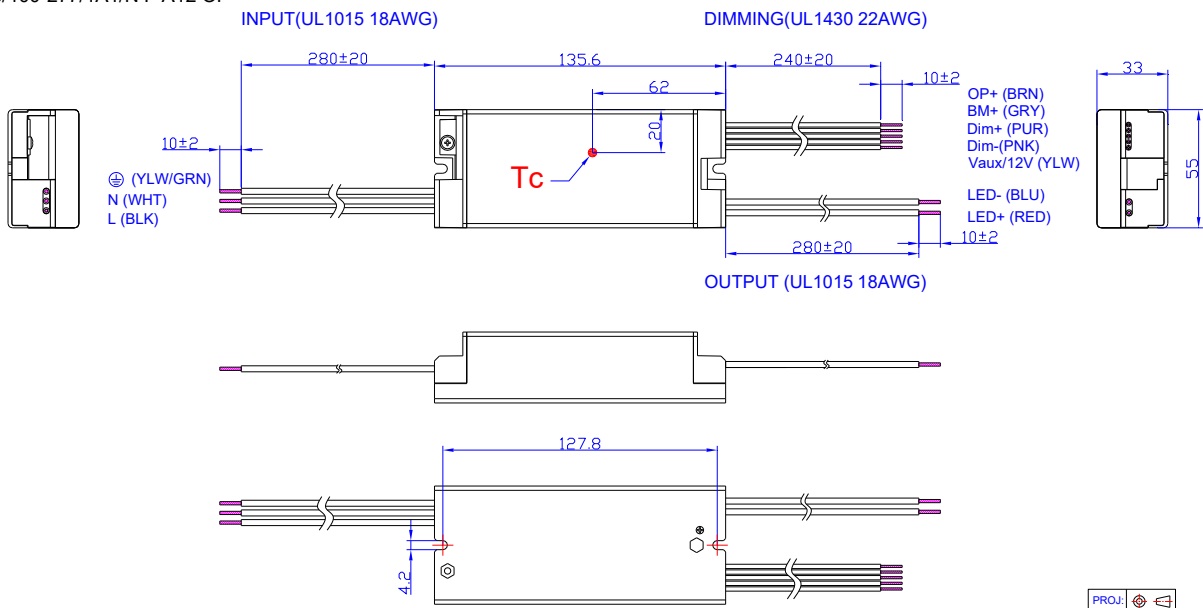

Unspecified tolerance: ±1

Environmental Compliance

RoHS

Our products comply with reference to RoHS Directive (EU) 2015/863 amending 2011/65/EU, calling for the elimination of lead and other hazardous substances from electronic products.

Product Order Overview

Order Code & Packaging

Order Code (EAN)	Product Version Name	Certification Markings on Product	Packaging unit (Pieces/Box)	Packing Dimensions (L x W x H)(mm)	Gross Weight (Kg)
6937186162342	IT 0-10 240/100-277/1A1/N E A12 OP	Class P, ENEC, CE	48	540 x 355 x 310	23.7
6937186162946	IT 0-10 240/100-277/1A1/N F A12 OP	Class P, ENEC, CE	48	540 x 355 x 310	23.7