

The IT 0-10 200/100-277/N series is a 200W, constant-current and IP20 rated LED driver that operates from 90-305Vac input with excellent power factor. Created for area lighting application, this family provides an auxiliary voltage and dim-to-off functionality for powering low voltage sensors. The dimming control supports 0(1)-10V, PWM dimming, resistor dimming, and AstroDIM dimming. The high efficiency of these drivers and compact metal case enables them to run cooler, significantly improving reliability and extending product life. To ensure trouble-free operation, protection is provided against input surge, output over voltage, short circuit, and over temperature.



### Features

- Non-Isolated Design with Low Residual Output Voltage < 2 kV
- No Afterglow on Specific Models
- Ultra High Efficiency (Up to 97%)
- Full Power at Wide Output Current Range (Constant Power)
- Adjustable Output Current (AOC) with T4T(Tuner4TRONIC)
- Isolated 0(1)-10V/PWM/Resistor/AstroDIM(Timer) Dimmable
- Dim-to-Off with Standby Power  $\leq 0.5$  W
- Adjustable Dimming Curve
- Always-on Auxiliary Power: 12Vdc, 200mA
- End-of-Life Indicator
- Override Dimming
- Constant Lumen
- Additional port (BM+) for current setting via external Dip Switch
- Additional port (OP+) for external Light Sensor on Specific Models
- Input Surge Protection: DM 6kV, CM 6kV
- All-Around Protection: OTP, OVP, SCP
- 5 Years Warranty

### Application

- IP20 Design and Suitable for Outdoor Applications in Luminaires with IP>54
- Suitable for Luminaires with Protection Class I
- Suitable for Built-in Use

### Models

| Adjustable Output Current Range(mA) | Full Power Current Range (mA) <sup>(1)</sup> | Default Output Current (mA) | Nominal Output Voltage Range(Vdc) | Maximum Output Power(W) <sup>(2)</sup> | Typical Efficiency <sup>(3)</sup> | Power Factor $\lambda$ | Product Name <sup>(4)(5)</sup> |
|-------------------------------------|--|-----------------------------|-----------------------------------|--|-----------------------------------|------------------------|--------------------------------|
| 67-900                              | 667-900                                      | 830                         | 180-300                           | 200                                    | 96.0%                             | 0.97                   | IT 0-10 200/100-277/0A9/N y    |

- Notes:** (1) Output current range with constant power at 200W.  
 (2) Output power shall not exceed the rated maximum.  
 (3) Measured at 100% load and 230Vac input (see below "General Specifications" for details).  
 (4) Certified input voltage range: 100-277Vac.  
 (5) Definition of y (see below "Product Version Description" for details).

## Product Version Description

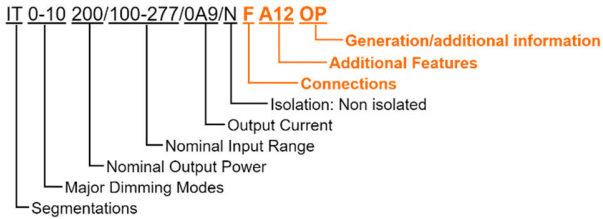
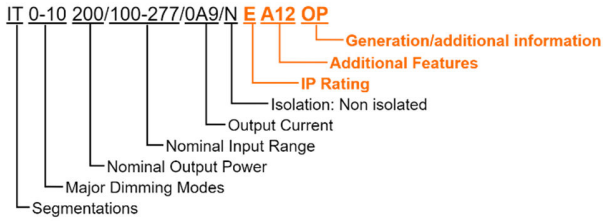

| Markers                           | Value | Definition       | Notes        |
|-----------------------------------|-------|------------------|--------------|
| IP rating                         | Blank | IP20             | Indoor       |
|                                   | E     | IP20             | Outdoor      |
| Connections                       | Blank | Push Terminals   |              |
|                                   | F     | Flying Leads     |              |
| Additional Features               | A12   | Aux-12V          |              |
| Generation/additional information | Blank | First generation |              |
|                                   | OP    | Optical Sensor   | Light Sensor |

## Input Specifications

| Parameter                                | Min.    | Typ. | Max.     | Notes  |
|--|---------|------|----------|--|
| Input Voltage AC                         | 90 Vac  | -    | 305 Vac  |  |
| Input Voltage DC                         | 127 Vdc | -    | 300 Vdc  |  |
| Mains Frequency                          | 47 Hz   | -    | 63 Hz    |  |
| Leakage Current                          | -       | -    | 0.75 MIU | UL 8750; 277Vac/60Hz                             |
|  | -       | -    | 0.70 mA  | IEC 60598-1; 277ac/60Hz                          |
| Nominal Input Current                    | -       | -    | 1.96 A   | Measured at 100% load and 120 Vac input.         |
|  | -       | -    | 1.03 A   | Measured at 100% load and 230 Vac input.         |
| Power Factor $\lambda$                   | 0.9     | -    | -        | At 100-277Vac, 50-60Hz, 70%-100% Load (140-200W) |
| Total Harmonic Distortion                | -       | -    | 20%      |  |
| Power Factor $\lambda$ Extended Range    | 0.95    | 0.97 | -        | At 220-240Vac, 50-60Hz, 100% load                |
| Total Harmonic Distortion Extended Range | -       | 8%   | 10%      |  |

## Output Specifications

| Parameter                      | Min.  | Typ.    | Max.     | Notes                                      |
|--------------------------------|-------|---------|----------|--|
| Programmable Output Current    | 67mA  | -       | 900 mA   |  |
| Nominal Output Voltage         | 180 V | -       | 300 V    |  |
| Output Current Tolerance       | -5%   | -       | +5%      | At 100% load condition                     |
| Total Output Current Ripple HF | -     | -       | 10%Iomax | At 100% load condition. 20 MHz BW (pk-avg) |
| Output Current Ripple LF       | -     | 5%Iomax | -        | At 100% load condition, <200 Hz (pk-avg)   |
| $P_{stLM}$                     | -     | -       | 1.0      |  |
| SVM                            | -     | -       | 0.4      |  |
| Startup Overshoot Current      | -     | -       | 10%Iomax | At 100% load condition                     |

## Output Specifications (Continued)

| Parameter                       | Min.   | Typ.     | Max.   | Notes                                       |
|---------------------------------|--------|----------|--------|---|
| U <sub>out</sub>                | -      | -        | 350 V  |   |
| Line Regulation                 | -      | -        | ± 3.0% | Measured at 100% load                       |
| Load Regulation                 | -      | -        | ± 5.0% |   |
| Turn-on Delay Time              | -      | -        | 1.0 s  | Measured at 120-277Vac input, 70%-100% load |
| Temperature Coefficient         | -      | 0.03%/°C | -      | Case temperature = 0°C ~T <sub>c</sub> max  |
| Auxiliary Output Voltage        | 10.8 V | 12 V     | 13.2 V | Return terminal is "Dim--"                  |
| Auxiliary Output Source Current | 0 mA   | -        | 200 mA |   |

## General Specifications

| Parameter  | Min.  | Typ.           | Max.   | Notes   |
|--|---|----------------|--------|---|
| Efficiency at 120Vac Input<br>I <sub>o</sub> =667 mA<br>I <sub>o</sub> =900 mA | 92.0%<br>92.0%                                  | 94.0%<br>94.0% | -<br>- | Measured at 100% load and Steady-state temperature in 25°C ambient;<br>(Efficiency will be about 2.0% lower if measured immediately after startup.) |
| Efficiency at 230Vac Input<br>I <sub>o</sub> =667 mA<br>I <sub>o</sub> =900 mA | 94.0%<br>94.0%                                  | 96.0%<br>96.0% | -<br>- | Measured at 100% load and Steady-state temperature in 25°C ambient;<br>(Efficiency will be about 2.0% lower if measured immediately after startup.) |
| Efficiency at 277Vac Input<br>I <sub>o</sub> =667 mA<br>I <sub>o</sub> =900 mA | 95.0%<br>94.0%                                  | 97.0%<br>96.0% | -<br>- | Measured at 100% load and Steady-state temperature in 25°C ambient;<br>(Efficiency will be about 2.0% lower if measured immediately after startup.) |
| Networked Standby Power  | -   | -              | 0.5 W  | Measured at 230Vac/50Hz; Dimming off  |
| MTBF   | -   | 352,000 Hours  | -      | Measured at 230Vac input, 80%Load and 25°C ambient temperature (MIL-HDBK-217F)  |
| Surge Protection (L - N)   | 6KV   | -              | -      | 2ohm, IEC 61000-4-5   |
| Surge Protection (L/N - E)   | 6KV   | -              | -      | 12ohm, IEC 61000-4-5  |
| Operating Case Temperature for Safety T <sub>c_s</sub>                         | -40°C   | -              | +90°C  |   |
| Operating Case Temperature for Warranty T <sub>c_w</sub>                       | -40°C   | -              | +85°C  | Case temperature for 5 years warranty<br>Humidity: 10% RH to 95% RH; No Condensation  |
| Lifetime   | -   | 120,000 Hours  | -      | Measured at 230Vac input, 80%load and 75°C case temperature; See lifetime vs. tc curve for the details  |
| Ambient Temperature  | -40°C   | -              | +60°C  | Measured at 230Vac input, 100% load   |
| Permitted rel. Humidity During Operation                                       | 5%  | -              | 95%    | No Condensation   |
| Temperature at Storage   | -40°C   | -              | +85°C  | Humidity: 5%RH to 95%RH, No Condensation  |
| Mains Switching Cycles   | 100,000   | -              | -      |   |
| IP Rating  | IP20  |                |        |   |
| Dimensions (L × W ×H)  | 5.34 x 2.17 x 1.30 inches<br>135.6 x 55 x 33 mm |                |        | Mounting distance<br>5.03 inches<br>127.8 mm  |
| Net Weight   | -   | 410 g          | -      |   |

## Inrush Current Waveform

| Input AC Voltage | Inrush Current<br>$I_{peak}$ | Inrush Current Width $t_{width}$<br>(@ 50% $I_{peak}$ ) | The Number of LED Driver can be Configured (MCB) |      |      |      |      |      |      |      |
|------------------|------------------------------|---|--|------|------|------|------|------|------|------|
|                  |                              |   | B10A   | B16A | B20A | B25A | C10A | C16A | C20A | C25A |
| 120Vac           | 35.8 A                       | 240 $\mu$ s   | 3  | 5    | 6    | 8    | 3    | 6    | 7    | 9    |
| 230Vac           | 77.5 A                       | 220 $\mu$ s   | 4  | 7    | 9    | 11   | 7    | 12   | 15   | 18   |
| 277Vac           | 90.5 A                       | 224 $\mu$ s   | 4  | 7    | 8    | 11   | 7    | 11   | 14   | 18   |

Notes: The maximum number of units per circuit breaker is an indicative value.

## Dimming Specifications

| Parameter                                    | Min.                         | Typ.        | Max.        | Notes  |   |
|--|------------------------------|-------------|-------------|--|---|
| Absolute Maximum Voltage on the Vdim (+) Pin | -20 V                        | -           | 20 V        |  |   |
| Source Current on Vdim (+)Pin                | 95 $\mu$ A                   | 100 $\mu$ A | 105 $\mu$ A | Vdim(+) = 0 V  |   |
| Dimming Output Range                         | 10%loset                     | -           | loset       | 667 mA $\leq$ loset $\leq$ 900 mA                    |   |
|  | 67 mA                        | -           | loset       | 67 mA $\leq$ loset < 667 mA                          |   |
| AstroDIM (Timer)                             | 10%                          | -           | 100%        |  |   |
| Dimming for 0(1)-10V                         | 0 V                          | -           | 10 V        | Dimming mode set to 0(1)-10V in T4T.                 |   |
| Dim off Voltage                              | 0.50 V                       | 0.75 V      | 0.90 V      |  |   |
| Dim on Voltage                               | 0.75 V                       | 1.0 V       | 1.15 V      |  |   |
| Hysteresis                                   | -                            | 0.2 V       | -           |  |   |
| Recommended Dimming for 0(1)-10V             | 1 V                          | -           | 9 V         | Default 0-10V dimming mode with positive logic.      |   |
| Dimming Curve Adjustable                     | 0 V                          | -           | 10 V        | Dimming mode set to Adjustable Dimming Curve in T4T. |   |
| PWM_in High Level                            | 3 V                          | -           | 10 V        | Dimming mode set to PWM Dimming in T4T.              |   |
| PWM_in Low Level                             | -0.3 V                       | -           | 0.6 V       |  |   |
| PWM_in Frequency                             | 200 Hz                       | -           | 3 KHz       |  |   |
| PWM_in Duty Cycle                            | 1%                           | -           | 99%         |  |   |
| PWM Dimming off (Positive Logic)             | 3%                           | 5%          | 8%          |  |   |
| PWM Dimming on (Positive Logic)              | 5%                           | 7%          | 10%         |  |   |
| PWM Dimming off (Negative Logic)             | 92%                          | 95%         | 97%         |  |   |
| PWM Dimming on (Negative Logic)              | 90%                          | 93%         | 95%         |  |   |
| Hysteresis                                   | -                            | 2%          | -           |  |   |
| Dip Switch Port (BM+)                        | Output Current Setting Range | 67 mA       | -           | 900 mA   | Output current can be set in T4T.                                       |
|  | Current 1                    | -           | 500 mA      | -  | Resistor value between BM+ and Dim- 470 Ohm                             |
|  | Current 2                    | -           | 670 mA      | -  | Resistor value between BM+ and Dim- 1k Ohm                              |
|  | Current 3                    | -           | 830 mA      | -  | Resistor value between BM+ and Dim- 3.3k Ohm                            |
| Light Sensor Port (OP+)                      | OFF/Low signal               | 0 V         | 1.0 V       | 1.2 V  | Default: 5S action;<br>Time / Voltage / Dimming level can be set in T4T |
|  | ON/High signal               | 2.5 V       | 3.5 V       | 10.0 V   |   |

## Certificates & Standards

| Safety Category | Standard  |
|-----------------|---|
| UL/CUL          | UL 8750, CAN/CSA-C22.2 No. 250.13   |
| FCC Part 15     | ANSI C63.4 Class B  |
|                 | This device complies with Part 15 of the FCC Rules. Operation is subject to the following two conditions: [1] this device may not cause harmful interference, and [2] this device must accept any interference received, including interference that may cause undesired Operation. |
| ENEC            | EN 61347-1, EN 61347-2-13, EN IEC 62384   |
| CE              | EN 61347-1, EN 61347-2-13, EN IEC 55015, EN 61547, EN IEC 61000-3-2, EN 61000-3-3   |
| CB              | IEC 61347-1, IEC 61347-2-13   |
| CCC             | GB/T 19510.1, GB/T 19510.213, GB/T 17743, GB 17625.1  |
| KS              | KS C 7655   |

**Note:** (1) This LED driver meets the EMI specifications above, but EMI performance of a luminaire that contains it depends also on the other devices connected to the driver and on the fixture itself.

## Isolation Levels

|         | Input      | Output     | Dimming    | Aux        | Housing |
|---------|------------|------------|------------|------------|---------|
| Input   | N/A        | Non        | Reinforced | Reinforced | Basic   |
| Output  | Non        | N/A        | Reinforced | Reinforced | Basic   |
| Dimming | Reinforced | Reinforced | N/A        | Non        | Basic   |
| Aux     | Reinforced | Reinforced | Non        | N/A        | Basic   |
| Housing | Basic      | Basic      | Basic      | Basic      | N/A     |

**Note:** The LED module must be insulated at least for 2500V.

## Operating Window

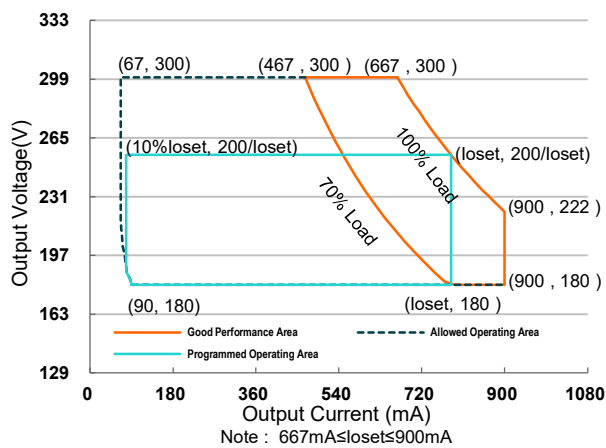

## Derating

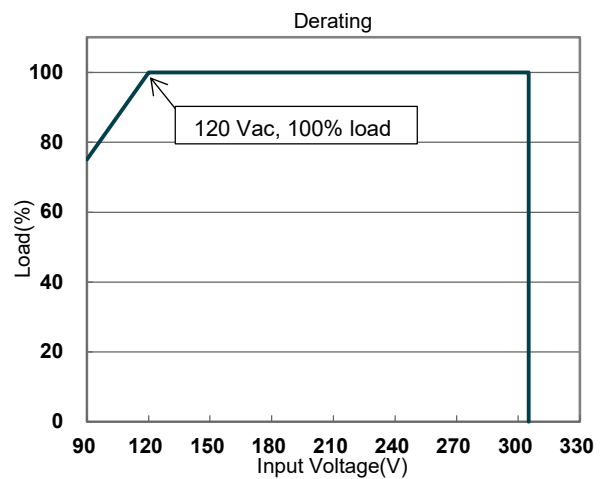

## Lifetime vs. Case Temperature

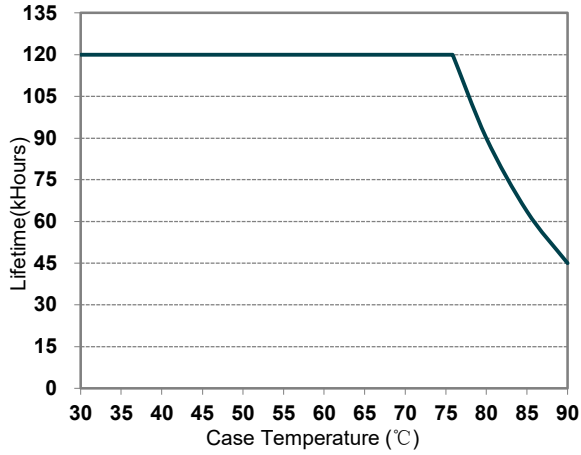

## Efficiency vs. Load@277Vac

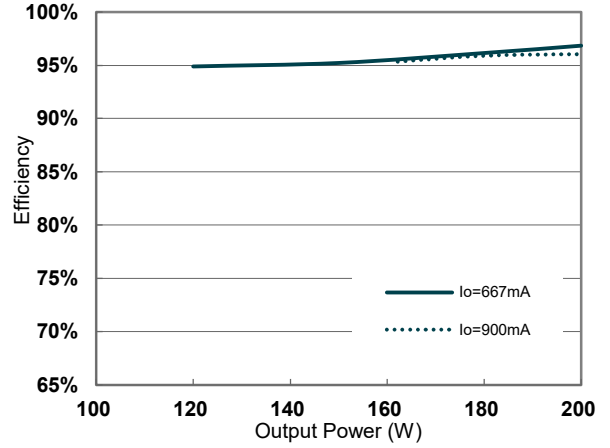

## Efficiency vs. Load@120Vac

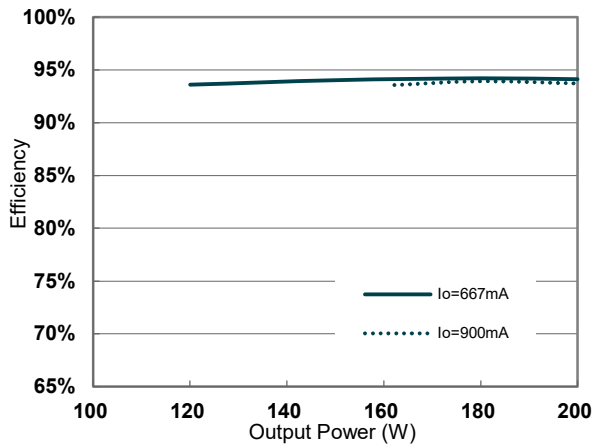

## Power Factor

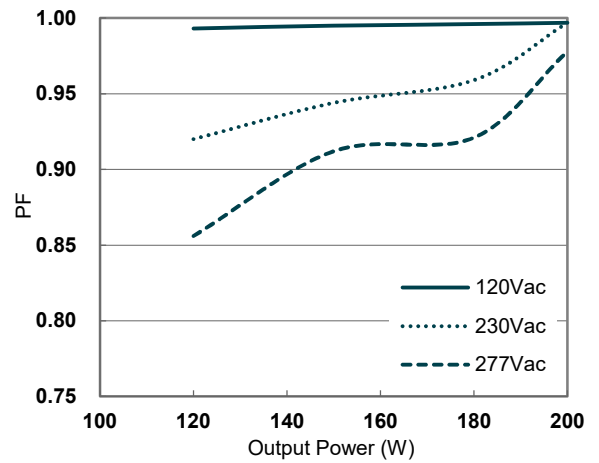

## Efficiency vs. Load@230Vac

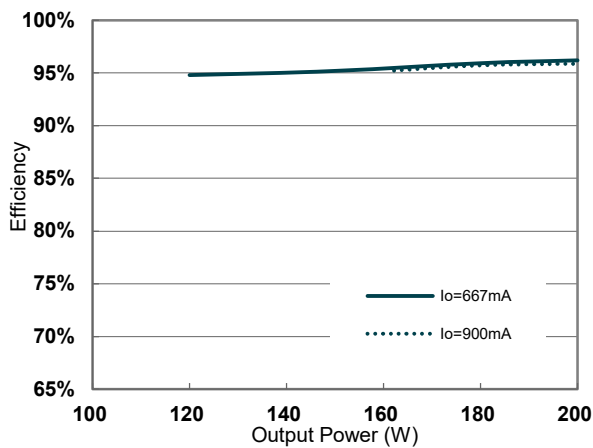

## Total Harmonic Distortion

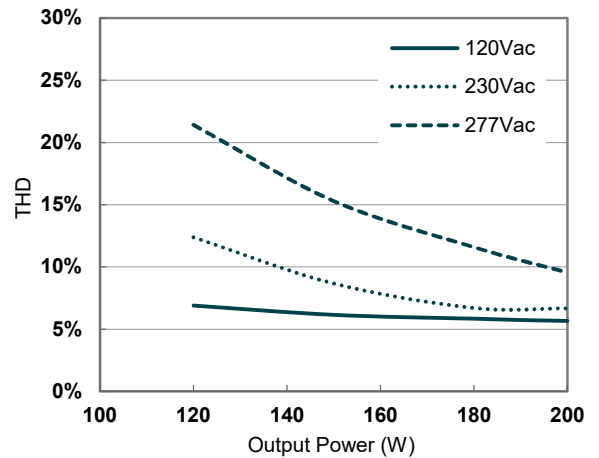

## Protection Functions

### Over Temperature Protection(OTP)

Protection based on safety: decreases output current if maximum internal temperature is reached, returning to normal value after over temperature is removed.

When output current reaches 20%, switch-off until over temperature is removed.

### Driver Guard

Default setting: disabled.

Protection based on lifetime: It can be activated via T4T. Set a lower internal temperature threshold (Thermal Settings: reduce the temperature threshold by 5°C, 10°C, 15°C or 20°C) to activate the over temperature protection.

## Dimming

### Adjustable Dimming Curve

0-10V curve can be set as corresponding dimming voltage by T4T. Take the 0-10V positive logic dimming mode as an example, the recommended implementation of the dimming control is provided below:

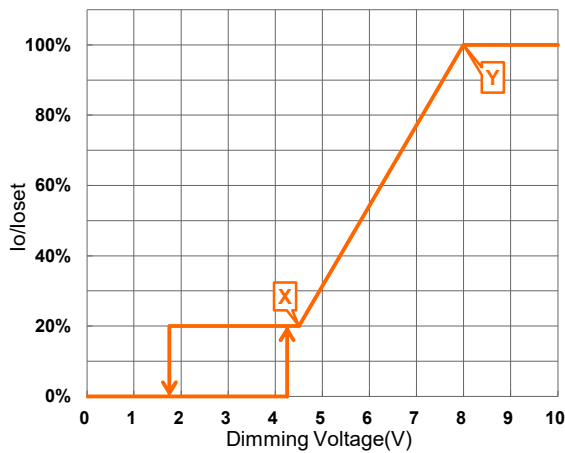

#### Notes:

1. Do NOT connect Dim- to the output V- or V+, otherwise the driver will not work properly.
2. The dimmer can also be replaced by an active 0-10V voltage source signal or passive components like zener.
3. When dimming voltage X point is set to be smaller than Y point, the dimming curve is positive logic; conversely, when X point is set to be bigger than Y point, the dimming curve is negative logic.
4. For best dimming accuracy, the difference between X point and Y point is advised not less than 4V.

### 0(1)-10V Dimming

The recommended implementation of the dimming control is provided below:

The driver is protected against temporary overheating by automatically reduction of the output current.

### Over Voltage Protection(OVP)

Limits output voltage at no load and in case the normal voltage limit fails.

### Short Circuit Protection(SCP)

Auto Recovery. No damage will occur when any output is short circuited. The output shall return to normal when the fault condition is removed.

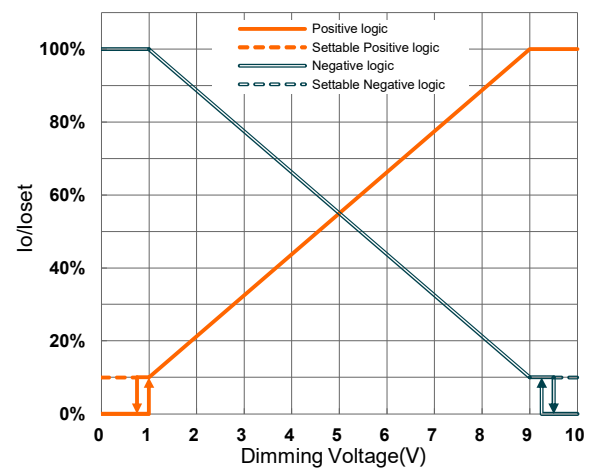

#### Notes:

1. Do NOT connect Dim- to the output V- or V+, otherwise the driver will not work properly.
2. The dimmer can also be replaced by an active 1-10V voltage source signal or passive components like zener.

### PWM Dimming

The recommended implementation of the dimming control is provided below:

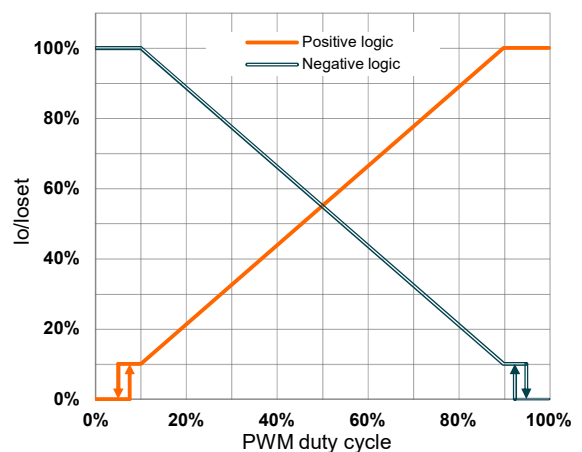

#### Notes:

1. Do NOT connect Dim- to the output V- or V+, otherwise the driver will not work properly.
2. When PWM negative logic dimming mode and Dim+ is open, the driver will dim to off and be standby.

## Resistor Dimming

The recommended implementation of the dimming control is provided below:

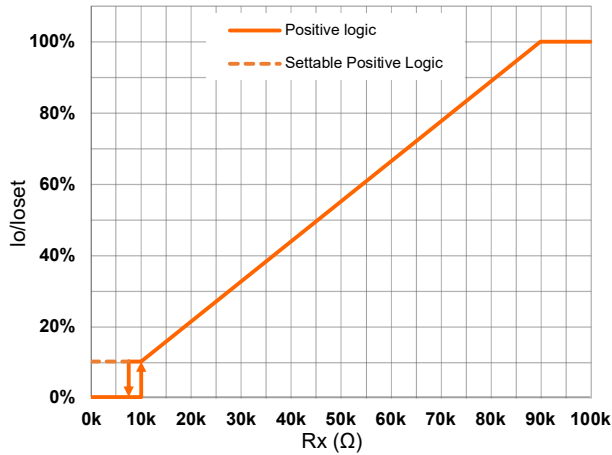

### Notes:

- Do NOT connect Dim- to the output V- or V+, otherwise the driver will not work properly.

## AstroDIM(Timer)

AstroDIM (Timer) includes 2 kinds of modes, they are Astro Based and Time Based.

- Astro Based:** The benchmark for the dimming profile is based on the average midnight each year, which is precisely calculated using theoretical sunrise and sunset times. The LED driver strictly adheres to

daily power-on and power-off times to execute the corresponding dimming configuration file. Furthermore, the adjustment of the dimming schedule is dynamic, automatically adapting according to the actual length of the night to ensure that the lighting effect aligns with nighttime environmental needs.

- Time Based:** The dimming profile defined in the reference schedule is referenced to the switch-on time of the LED driver.
- Override Dimming:** When the integrated "AstroDIM(Timer)+Override" is enabled, it is possible to override the dimming mode from 'AstroDIM' into 'Adjustable Dimming Curve' mode by applying a voltage of 1(0)-10V between DIM+ and DIM-. Once a voltage  $\leq 10.5$  Vdc is detected the output current will coincide with the dimming voltage. By opening the DIM+ and DIM- circuitry, the LED driver will switch again to AstroDIM mode. During override, our product continues to count while the AstroDIM is being overridden. Once the override is removed, the output current returns to the same point in its AstroDIM cycle.

## Constant Lumen

Constant lumen function may be used to maintain constant light output over the life of the LEDs by driving them at a reduced current when new, then gradually increasing the drive current over time to counteract LED lumen degradation. This function is disabled by default.

## End Of Life

End-of-Life (EOL) is providing a visual notification to a user that the LED module has reached the end of manufacturer-specified life and that the replacement is recommended. Once active, an indication is given at each power-up of the driver, which the driver indicates this through a lower light output (minimum output current level) during the first 10 minutes before normal operation is continue.

## Programming Connection Diagram

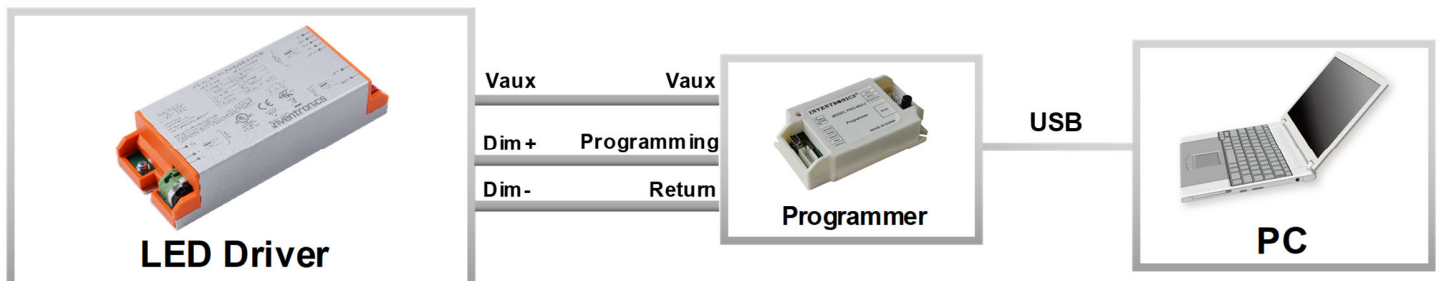

- Note:** (1) The driver does not need to be powered on during the programming process.  
 (2) Please refer to [PRG-MUL2](#) (Programmer) datasheet for details.  
 (3) Supports [I4T](#) functionality.

## Mechanical Outline

IT 0-10 200/100-277/0A9/N E A12 OP

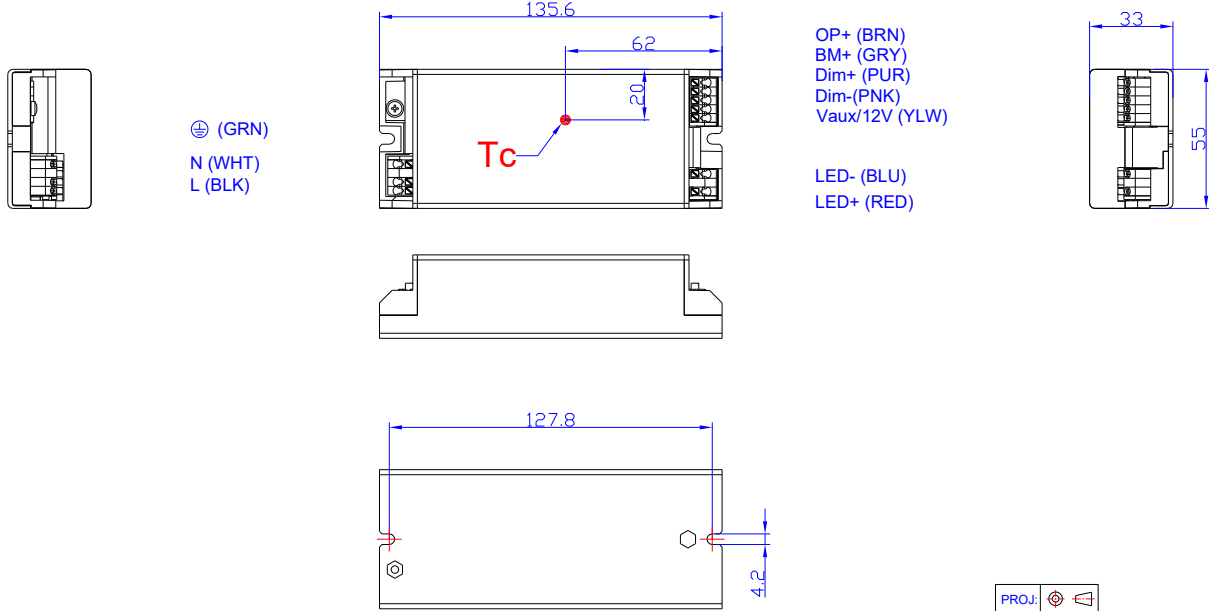

Unspecified tolerance: ±1

IT 0-10 200/100-277/0A9/N F A12 OP

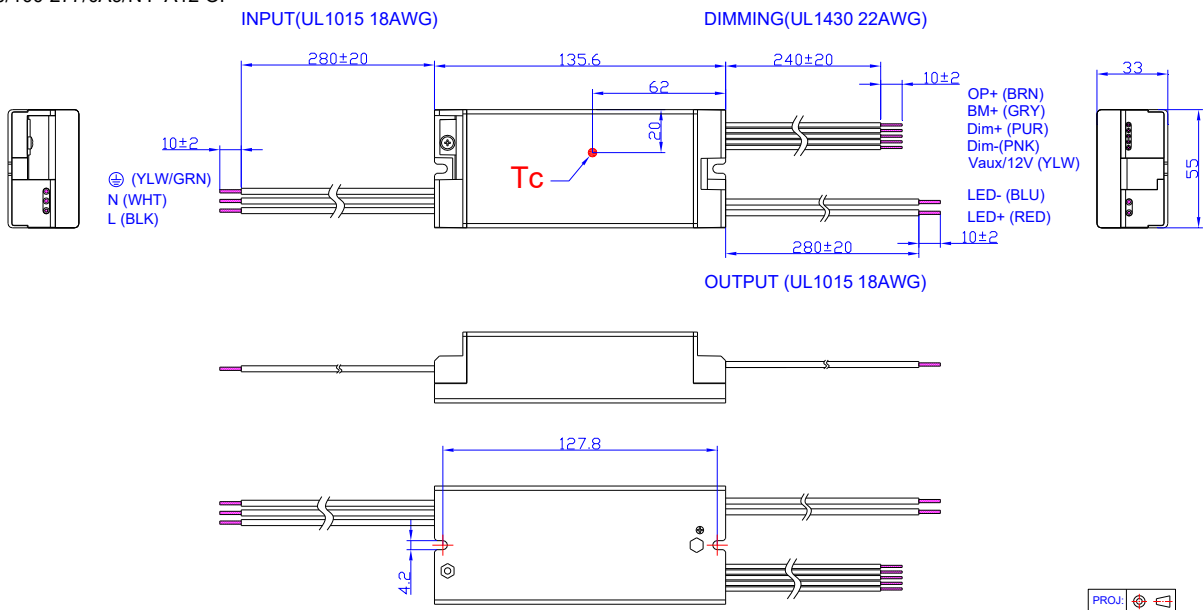

Unspecified tolerance: ±1

## Environmental Compliance

### RoHS

Our products comply with reference to RoHS Directive (EU) 2015/863 amending 2011/65/EU, calling for the elimination of lead and other hazardous substances from electronic products.

## Product Order Overview

### Order Code & Packaging

| Order Code (EAN) | Product Version Name               | Certification Markings on Product | Packaging unit (Pieces/Box) | Packing Dimensions (L x W x H)(mm) | Gross Weight (Kg) |
|------------------|------------------------------------|-----------------------------------|-----------------------------|------------------------------------|-------------------|
| 6937186162328    | IT 0-10 200/100-277/0A9/N E A12 OP | Class P, ENEC, CE                 | 48                          | 540 x 355 x 310                    | 23.5              |
| 6937186162922    | IT 0-10 200/100-277/0A9/N F A12 OP | Class P, ENEC, CE                 | 48                          | 540 x 355 x 310                    | 23.5              |