

## Features

- Full Power at Wide Output Current Range (Constant Power)
- Adjustable Output Current (AOC) with NFC
- DALI-2 Certified (Part 251, 252, 253)
- 3-Timer-Modes Dimmable
- Dim-to-Off with Standby Power  $\leq 0.5W$
- Integrated Power Monitoring with High Accuracy up to  $\pm 1\%$
- Output Lumen Compensation
- End-of-Life Indicator
- Input Surge Protection: DM 6kV, CM 10kV
- All-Around Protection: IUVP, IOVP, OVP, SCP, OTP
- IP66/IP67
- UL Dry/Damp/Wet Location (ET/EG models)
- TYPE HL, for Use in a Class I, Division 2 Hazardous (Classified) Location (ET/EG models)
- Suitable for Luminaires with Protection Class I
- Suitable for Luminaires with Protection Class I and II (EE models)
- 5 Years Warranty



## Description

The EUM-100SxxxEx series is a 100W, DALI-2, constant-current, NFC programmable and IP66/IP67 rated LED driver that operates from 90-305Vac input with excellent power factor. Created for intra-luminaire solutions and health monitoring applications, this family provides integrated AC power monitoring and dim-to-off functionality. The dimming control supports two-way communication via DALI-2. The high efficiency of these drivers and compact metal case enables them to run cooler, significantly improving reliability and extending product life. To ensure trouble-free operation, protection is provided against input surge, input under voltage, input over voltage, output over voltage, short circuit, and over temperature.

## Models

Adjustable Output Current Range (mA)	Full-Power Current Range (mA) <sup>(1)</sup>	Default Output Current (mA)	Output Voltage Range (Vdc)	Max. Output Power (W)	Typical Efficiency <sup>(2)</sup>	Typical Power Factor		Model Number <sup>(3)(6)(7)</sup>
						120Vac	220Vac	
35-530	350-530	530	94-286	100	92.0%	0.99	0.96	EUM-100S053Ex
70-1050	700-1050	700	48-143	100	91.5%	0.99	0.96	EUM-100S105Ex
105-1500	1050-1500	1050	34-95	100	91.5%	0.99	0.96	EUM-100S150Ex <sup>(4)</sup>
175-2800	1750-2800	2100	17-54	96	90.5%	0.99	0.96	EUM-100S280Ex <sup>(5)</sup>

**Notes:** (1) Output current range with constant power at 100W

(2) Measured at 100% load and 220Vac input (see below "General Specifications" for details).

(3) Certified input voltage range: UL, FCC 100-277Vac; otherwise 100-240Vac.

(4) SELV Output.

(5) LED Class 2, LVLE & SELV output

(6) All the models are certificated to KS, except EUM-100S053Ex.

(7) x = G are UL Recognized, ENEC and CCC, etc. models; x = T are UL Class P models; x = E are Class II models with ENEC, etc. x = B are BIS models. See below "Mechanical Outline" for details.

## I-V Operation Area

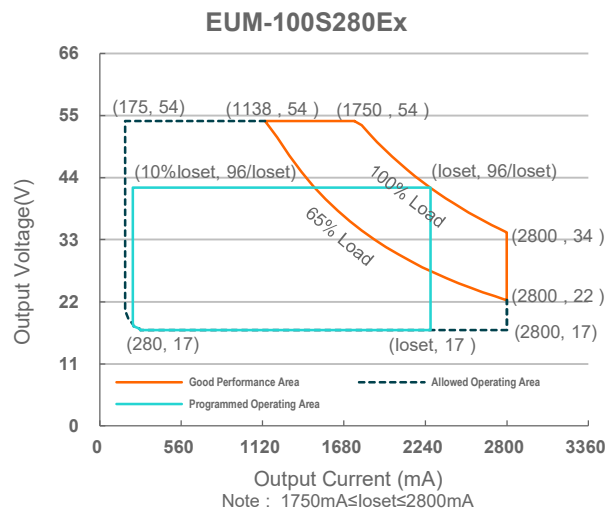
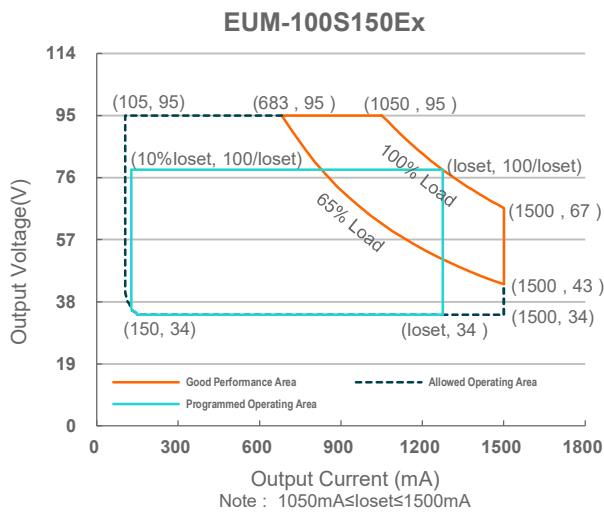
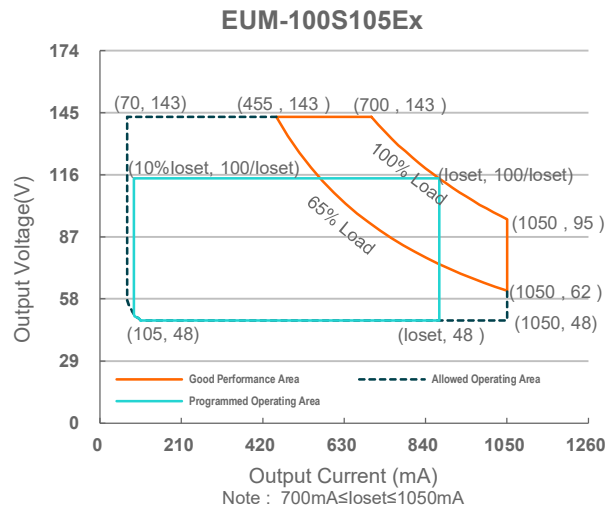
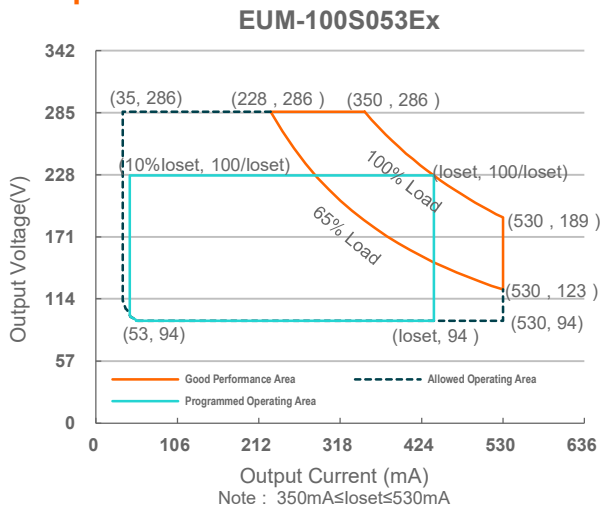

## Input Specifications

Parameter	Min.	Typ.	Max.	Notes
Input AC Voltage	90 Vac	-	305 Vac	
Input DC Voltage	127 Vdc	-	300 Vdc	
Input Frequency	47 Hz	-	63 Hz	
Leakage Current	-	-	0.75 MIU	UL 8750; 277Vac/60Hz
	-	-	0.70 mA	IEC 60598-1; 240Vac/60Hz
Input AC Current	-	-	1.06 A	Measured at 100%load and 120 Vac input.
	-	-	0.57 A	Measured at 100%load and 220 Vac input.
Inrush Current(I <sup>2</sup> t)	-	-	1.88 A <sup>2</sup> s	At 220Vac input, 25°C cold start, duration=256μs, 10%l <sub>pk</sub> -10%l <sub>pk</sub> .

## Input Specifications (Continued)

Parameter	Min.	Typ.	Max.	Notes
PF	0.9	-	-	At 100-277Vac, 50-60Hz, 65%-100% Load (65-100W)
THD	-	-	20%	
THD	-	-	10%	At 220-240Vac, 50-60Hz, 75%-100% Load (75-100W)

## Output Specifications

Parameter	Min.	Typ.	Max.	Notes
Output Current Tolerance	-5%loset	-	5%loset	At 100%load condition
Output Current Setting(loset) Range				
EUM-100S053Ex	35 mA	-	530 mA	
EUM-100S105Ex	70 mA	-	1050 mA	
EUM-100S150Ex	105 mA	-	1500 mA	
EUM-100S280Ex	175 mA	-	2800 mA	
Output Current Setting Range with Constant Power				
EUM-100S053Ex	350 mA	-	530 mA	
EUM-100S105Ex	700 mA	-	1050 mA	
EUM-100S150Ex	1050 mA	-	1500 mA	
EUM-100S280Ex	1750 mA	-	2800 mA	
Total Output Current Ripple (pk-pk)	-	5%lomax	10%lomax	At 100%load condition. 20 MHz BW
Output Current Ripple at < 200 Hz (pk-pk)	-	2%lomax	-	At 100%load condition. Only this component of ripple is associated with visible flicker.
Startup Overshoot Current	-	-	10%lomax	At 100%load condition
No Load Output Voltage				
EUM-100S053Ex	-	-	330 V	
EUM-100S105Ex	-	-	170 V	
EUM-100S150Ex	-	-	120 V	
EUM-100S280Ex	-	-	60 V	
Line Regulation	-	-	±1%	Measured at 100%load
Load Regulation	-	-	±5%	
Turn-on Delay Time	-	-	0.5 s	Measured at all dimming modes except DALI-2, and 120-277Vac input, 65%-100% Load
	-	-	1.0 s	Measured at DALI-2 dimming mode, and 120-277Vac input, 65%-100% Load
Temperature Coefficient of loset	-	0.06%/°C	-	Case temperature = 0°C~Tc max

## General Specifications

Parameter	Min.	Typ.	Max.	Notes
Efficiency at 120 Vac input: EUM-100S053Ex				
Io= 350 mA	87.5%	89.5%	-	
Io= 530 mA	87.5%	89.5%	-	
EUM-100S105Ex				Measured at 100% load and steady-state temperature in 25°C ambient; (Efficiency will be about 2.0% lower if measured immediately after startup.)
Io= 700 mA	87.5%	89.5%	-	
Io=1050 mA	87.5%	89.5%	-	
EUM-100S150Ex				
Io=1050 mA	87.5%	89.5%	-	
Io=1500 mA	87.5%	89.5%	-	
EUM-100S280Ex				
Io=1750 mA	86.5%	88.5%	-	
Io=2800 mA	86.0%	88.0%	-	
Efficiency at 220 Vac input: EUM-100S053Ex				
Io= 350 mA	90.0%	92.0%	-	Measured at 100% load and steady-state temperature in 25°C ambient; (Efficiency will be about 2.0% lower if measured immediately after startup.)
Io= 530 mA	90.0%	92.0%	-	
EUM-100S105Ex				
Io= 700 mA	89.5%	91.5%	-	
Io=1050 mA	89.5%	91.5%	-	
EUM-100S150Ex				
Io=1050 mA	89.5%	91.5%	-	
Io=1500 mA	89.5%	91.5%	-	
EUM-100S280Ex				
Io=1750 mA	88.5%	90.5%	-	
Io=2800 mA	88.0%	90.0%	-	
Efficiency at 277 Vac input: EUM-100S053Ex				
Io= 350 mA	90.5%	92.5%	-	Measured at 100% load and steady-state temperature in 25°C ambient; (Efficiency will be about 2.0% lower if measured immediately after startup.)
Io= 530 mA	90.0%	92.0%	-	
EUM-100S105Ex				
Io= 700 mA	90.0%	92.0%	-	
Io=1050 mA	90.0%	92.0%	-	
EUM-100S150Ex				
Io=1050 mA	90.0%	92.0%	-	
Io=1500 mA	89.5%	91.5%	-	
EUM-100S280Ex				
Io=1750 mA	88.5%	90.5%	-	
Io=2800 mA	88.0%	90.0%	-	
Power Monitoring Accuracy	-1%	-	1%	Measured at 220Vac input and 100%Load
Standby Power	-	-	0.5 W	Measured at 230Vac/50Hz; Dimming off
MTBF	-	343,000 Hours	-	Measured at 220Vac input, 80%Load and 25°C ambient temperature (MIL-HDBK-217F)
Lifetime	-	101,000 Hours	-	Measured at 220Vac input, 80%Load and 70°C case temperature; See lifetime vs. Tc curve for the details
Operating Case Temperature for Safety Tc_s	-40°C	-	+90°C	
Operating Case Temperature for Warranty Tc_w	-40°C	-	+80°C	Case temperature for 5 years warranty Humidity: 10% RH to 95% RH
Storage Temperature	-40°C	-	+85°C	Humidity: 5%RH to 95%RH

## General Specifications (Continued)

Parameter	Min.	Typ.	Max.	Notes
Dimensions Inches (L × W × H) Millimeters (L × W × H)		5.16 × 2.52 × 1.44 131 × 64 × 36.5		With mounting ear 5.83 × 2.52 × 1.44 148 × 64 × 36.5
Net Weight	-	655 g	-	

## Dimming Specifications

Parameter	Min.	Typ.	Max.	Notes	
DA, DA High Level	9.5 V	16 V	22.5 V		
DA, DA Low Level	-6.5 V	0 V	6.5 V		
DA, DA Current	0 mA	-	2 mA		
Dimming Output Range	EUM-100S053Ex EUM-100S105Ex EUM-100S150Ex EUM-100S280Ex	10%loset	-	loset	350 mA ≤ loiset ≤ 530 mA 700 mA ≤ loiset ≤ 1050 mA 1050 mA ≤ loiset ≤ 1500 mA 1750 mA ≤ loiset ≤ 2800 mA
	EUM-100S053Ex EUM-100S105Ex EUM-100S150Ex EUM-100S280Ex	35 mA 70 mA 105 mA 175 mA	-	loset	35 mA ≤ loiset < 350 mA 70 mA ≤ loiset < 700 mA 105 mA ≤ loiset < 1050 mA 175 mA ≤ loiset < 1750 mA

## Safety & EMC Compliance

Safety Category	Standard
UL/CUL	UL 8750,CAN/CSA-C22.2 No. 250.13
ENEC	EN 61347-1 <sup>(1)</sup> , EN 61347-2-13
CE	EN 61347-1 <sup>(1)</sup> , EN 61347-2-13 EN 301 489-1 EN 301 489-3 EN 300 330 EN 62479/EN 50663/EN 50665/EN 50364
CB	IEC 61347-1 <sup>(1)</sup> , IEC 61347-2-13
CCC	GB 19510.1, GB 19510.14
KS	KS C 7655
BIS	IS 15885(Part2/Sec13)
global-mark	AS/NZS 61347.1, AS/NZS 61347.2.13
Performance	Standard
ENEC	EN IEC 62384

## Safety & EMC Compliance (Continued)

EMI Standards	Notes
EN IEC 55015/GB/T 17743 <sup>(2)</sup>	Conducted emission Test & Radiated emission Test
EN IEC 61000-3-2/GB 17625.1	Harmonic current emissions
EN 61000-3-3	Voltage fluctuations & flicker
FCC Part 15 <sup>(2)</sup>	ANSI C63.4 Class B
	This device complies with Part 15 of the FCC Rules. Operation is subject to the following two conditions: [1] this device may not cause harmful interference, and [2] this device must accept any interference received, including interference that may cause undesired Operation.
EMS Standards	Notes
EN 61000-4-2	Electrostatic Discharge (ESD): 8 kV air discharge, 4 kV contact discharge
EN 61000-4-3	Radio-Frequency Electromagnetic Field Susceptibility Test-RS
EN 61000-4-4	Electrical Fast Transient / Burst-EFT
EN 61000-4-5	Surge Immunity Test: AC Power Line: Differential Mode 6 kV, Common Mode 10 kV
EN 61000-4-6	Conducted Radio Frequency Disturbances Test-CS
EN 61000-4-8	Power Frequency Magnetic Field Test
EN 61000-4-11	Voltage Dips
EN 61547	Electromagnetic Immunity Requirements Applies To Lighting Equipment
DALI-2 Standards	Notes
DALI-2 <sup>(3)</sup>	IEC 62386-101, 102 & 207

**Notes:** (1) EE models meet the requirements for EN/IEC 61347-1(Class II), when the driver is energized, the allowed leakage current is perceptible but harmless.

(2) This LED driver meets the EMI specifications above, but EMI performance of a luminaire that contains it depends also on the other devices connected to the driver and on the fixture itself.

(3) DALI Parts: 101, 102, 207, 251, 252, 253.

## Derating

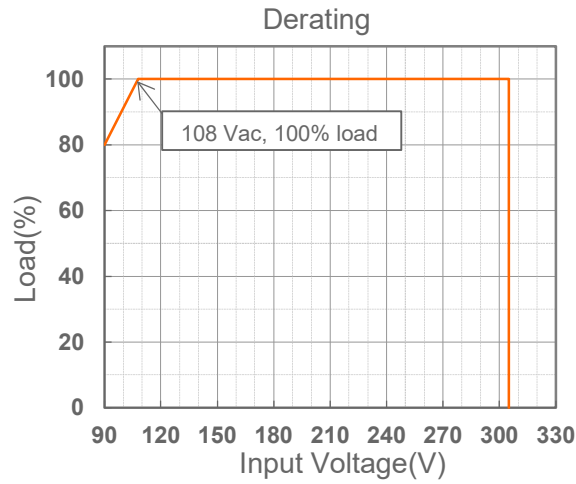

## Lifetime vs. Case Temperature

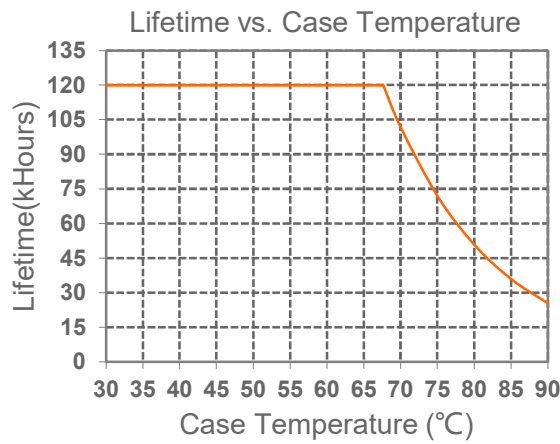

## Inrush Current Waveform

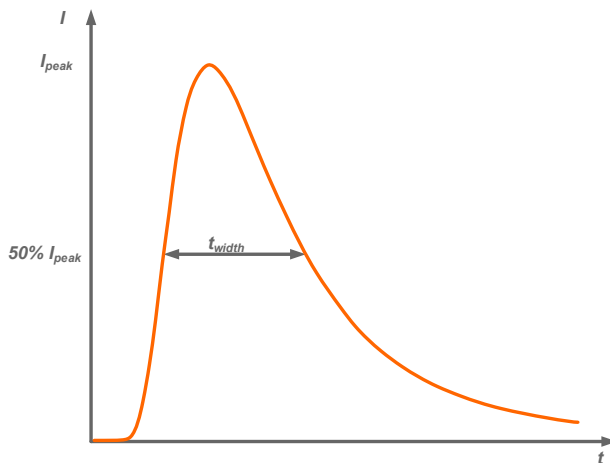

Input AC Voltage	$I_{peak}$	$t_{width}$ (@ 50% $I_{peak}$ )
120 Vac	53.4 A	104 $\mu s$
220 Vac	99 A	102 $\mu s$
277 Vac	126 A	106 $\mu s$

## Inrush Current Waveform (Continued)

MCB	Tripping Curves	B	B	B	B	C	C	C	C
	Rated Current	10A	16A	20A	25A	10A	16A	20A	25A
The Number of LED Driver can be Configured	120 Vac	6	10	12	16	7	11	14	18
	220 Vac	8	12	16	20	13	21	26	33
	277 Vac	6	9	12	15	10	16	20	25

## Efficiency vs. Load

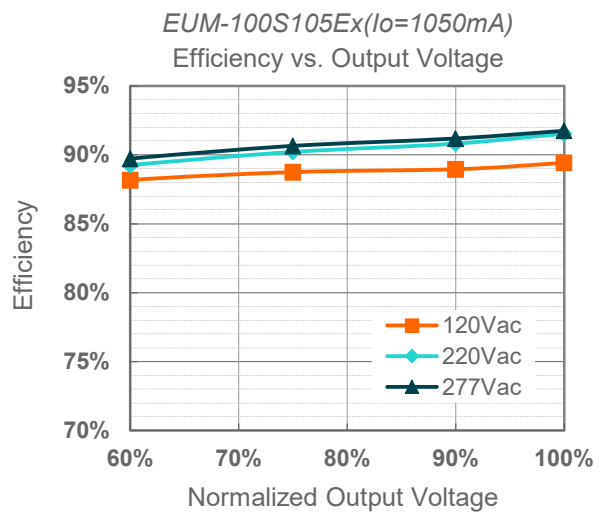
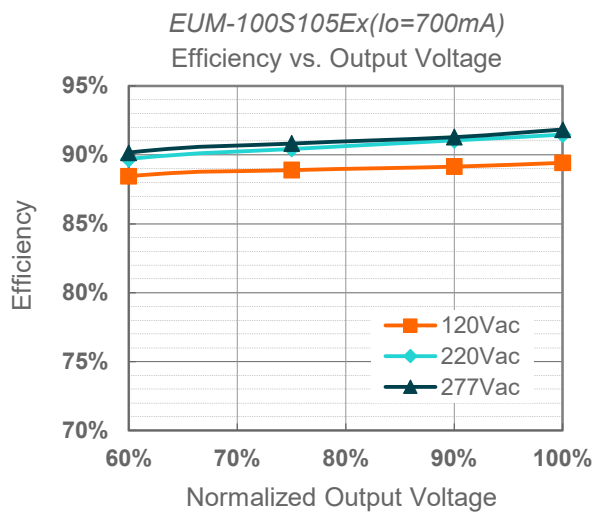
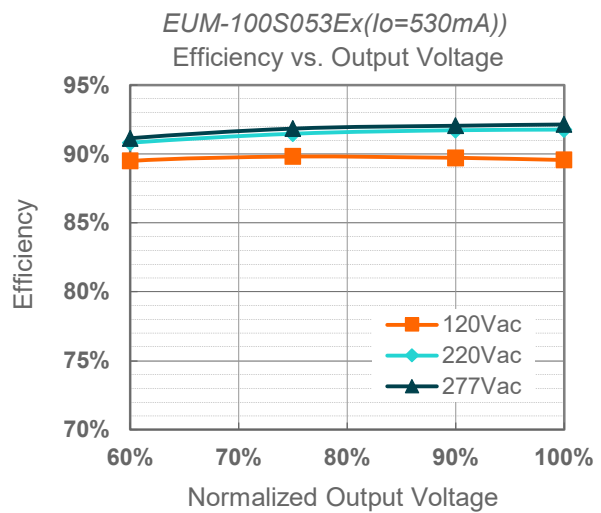
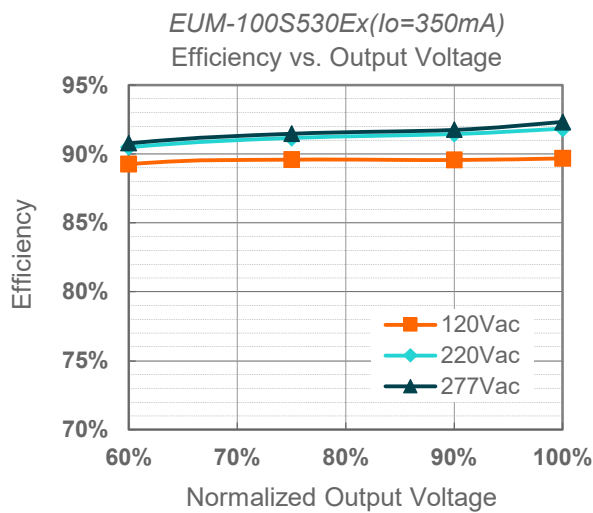

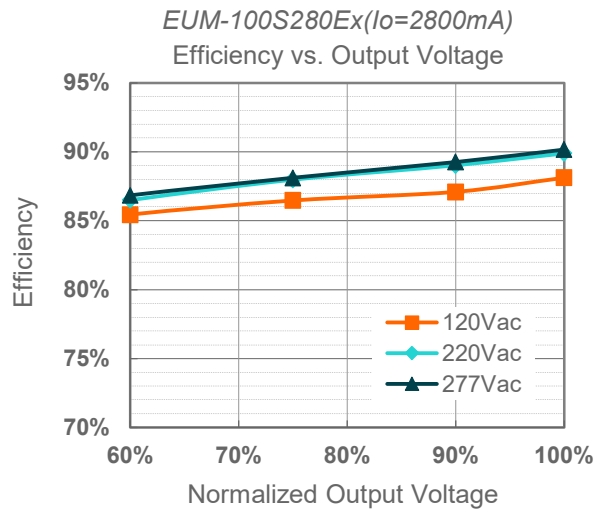
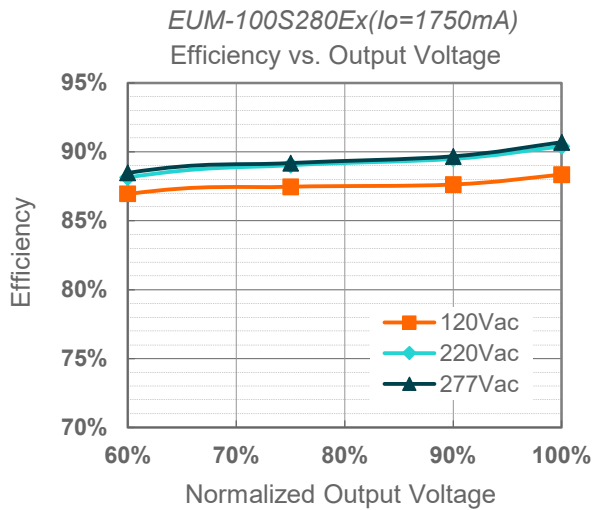
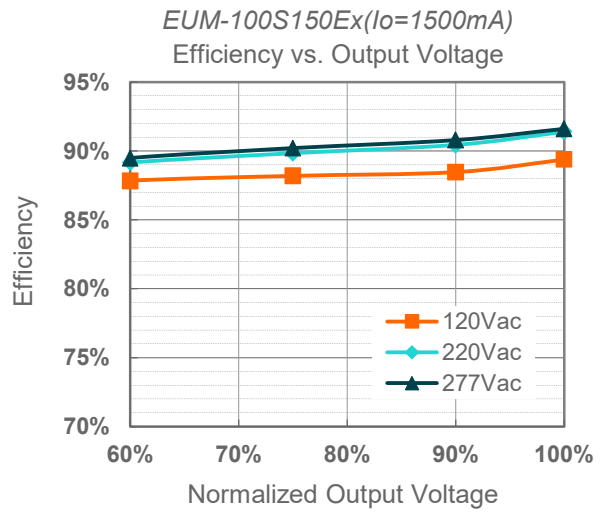
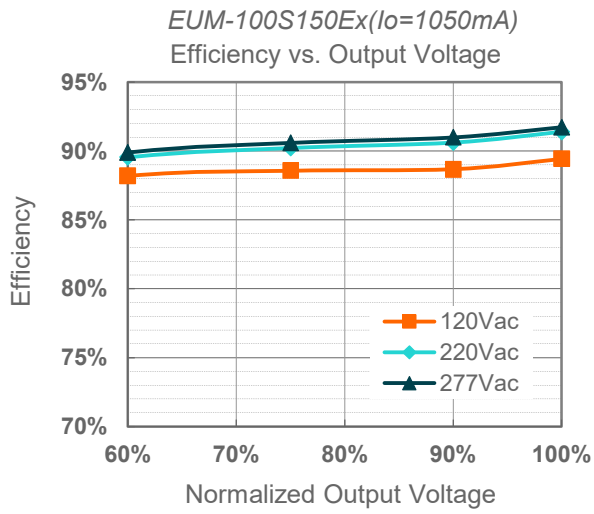

## Power Factor

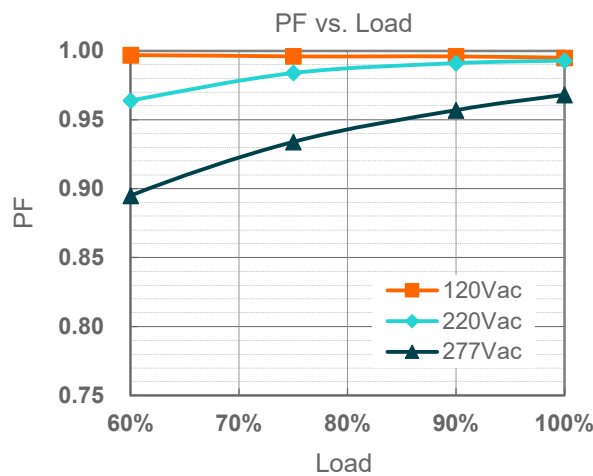

## Total Harmonic Distortion

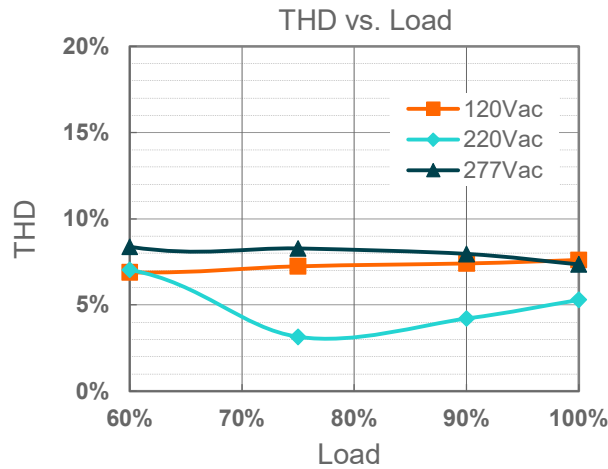

## Protection Functions

Parameter		Min.	Typ.	Max.	Notes
Over Voltage Protection		Limits output voltage at no load and in case the normal voltage limit fails.			
Short Circuit Protection		Auto Recovery. No damage will occur when any output is short circuited. The output shall return to normal when the fault condition is removed.			
Over Temperature Protection		Decreases output current, returning to normal after over temperature is removed.			
Input Under Voltage Protection (IUVP)	Input Under Voltage Protection	70 Vac	80 Vac	90 Vac	Turn off the output when the input voltage falls below protection voltage.
	Input Under Voltage Recovery	75 Vac	85 Vac	95 Vac	Auto Recovery. The driver will restart when the input voltage exceeds recovery voltage.
Input Over Voltage Protection	Input Over Voltage Protection	310 Vac	320 Vac	330 Vac	Turn off the output when the input voltage exceeds protection voltage.
	Input Over Voltage Recovery	300 Vac	310 Vac	320 Vac	Auto Recovery. The driver will restart when the input voltage falls below recovery voltage.
	Max. of Input Over Voltage	-	-	350 Vac	The driver can survive stabilized input over voltage conditions up to 350Vac for a total of 8 hours.

## ● Input Under Voltage Protection Diagram

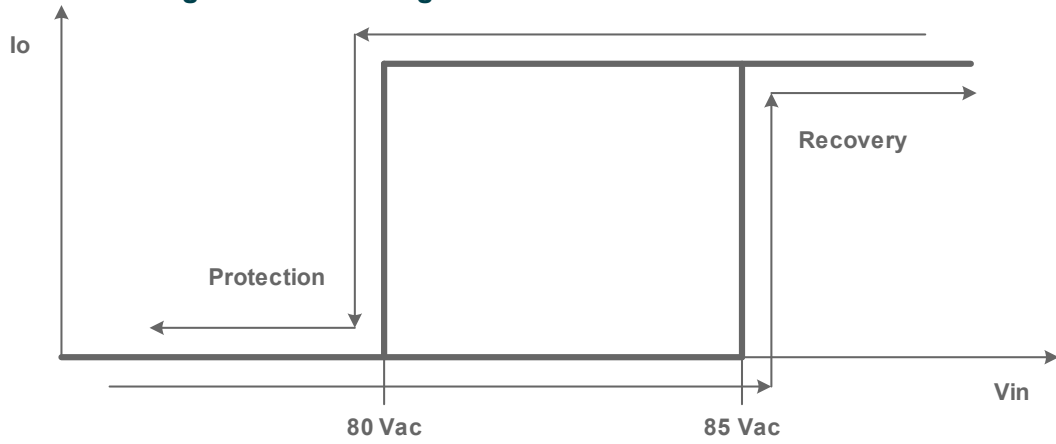

## ● Input Over Voltage Protection Diagram

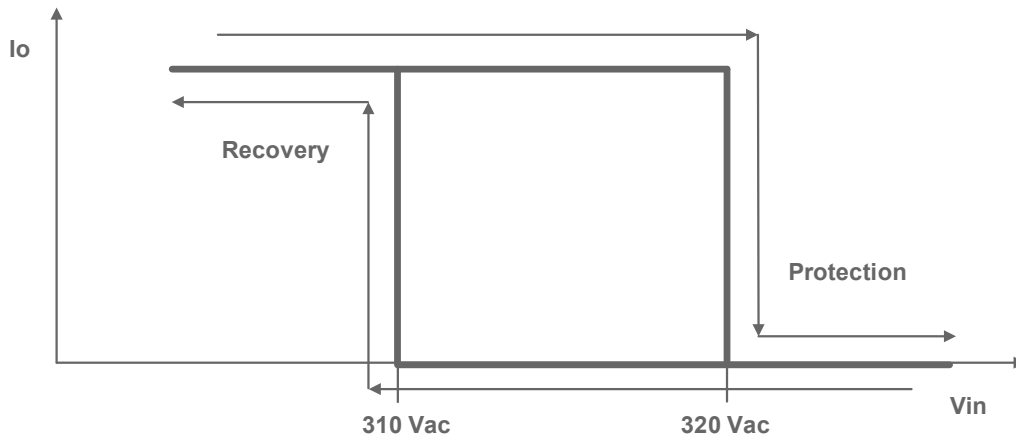

## Dimming

### ● DALI-2 Dimming

The recommended implementation of the dimming control is provided below.

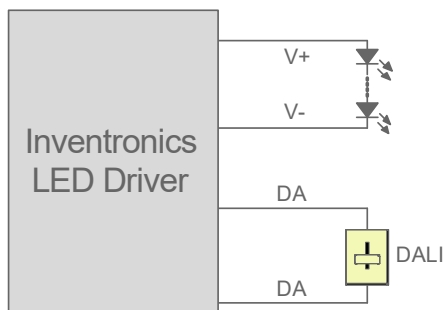

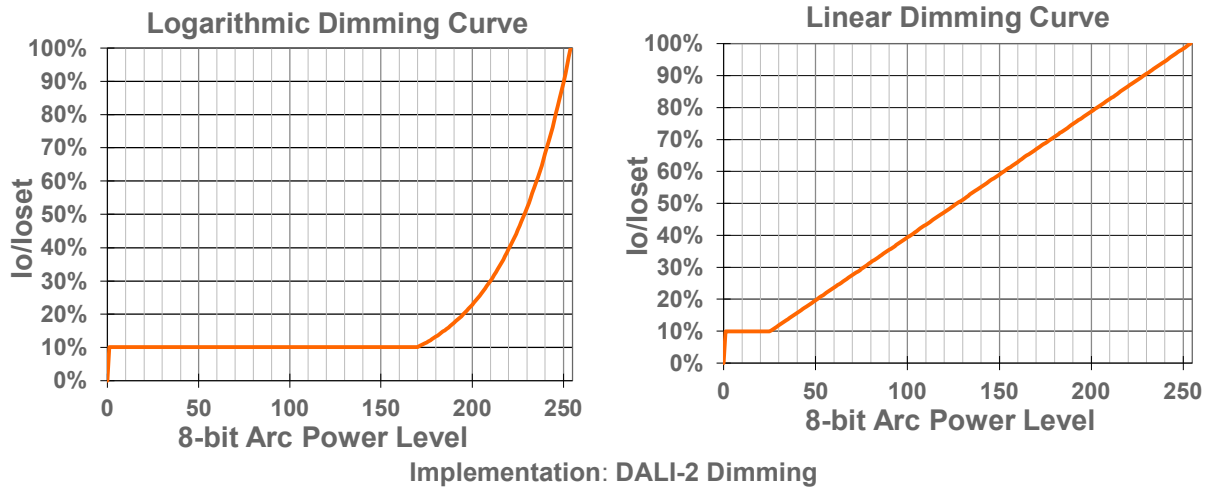

## ● Time Dimming

Time dimming control includes 3 kinds of modes, they are Self Adapting-Midnight, Self Adapting-Percentage and Traditional Timer.

- **Self Adapting-Midnight:** Automatically adjusts the dimming curve based on the on-time of past two days (if difference <15 minutes), assuming that the center point of the dimming curve is midnight local time.
- **Self Adapting-Percentage:** Automatically adjusts the on-time of each step by a constant percentage = (actual on-time for the past 2 days if difference <15 min) / (programmed on-time from the dimming curve).
- **Traditional Timer:** Follows the programmed timing curve after power on with no changes.

## ● Output Lumen Compensation

Output Lumen Compensation (OLC) may be used to maintain constant light output over the life of the LEDs by driving them at a reduced current when new, then gradually increasing the drive current over time to counteract LED lumen degradation.

## ● End Of Life

End-of-Life (EOL) is providing a visual notification to a user that the LED module has reached the end of manufacturer-specified life and that the replacement is recommended. Once active, an indication is given at each power-up of the driver, which the driver indicates this through a lower light output during the first 1 minute before normal operation is continued.

## Programming Connection Diagram

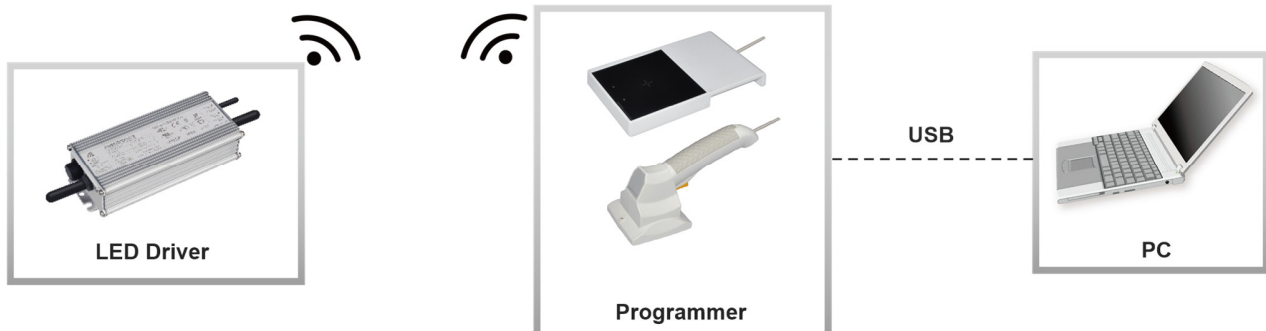

**Note:** The driver does not need to be powered on during the programming process.

● Please refer to [PRG-NFC-H](#) or [PRG-NFC-D2](#) (Programmer) datasheet for details.

## Mechanical Outline

### EUM-100SxxxEG

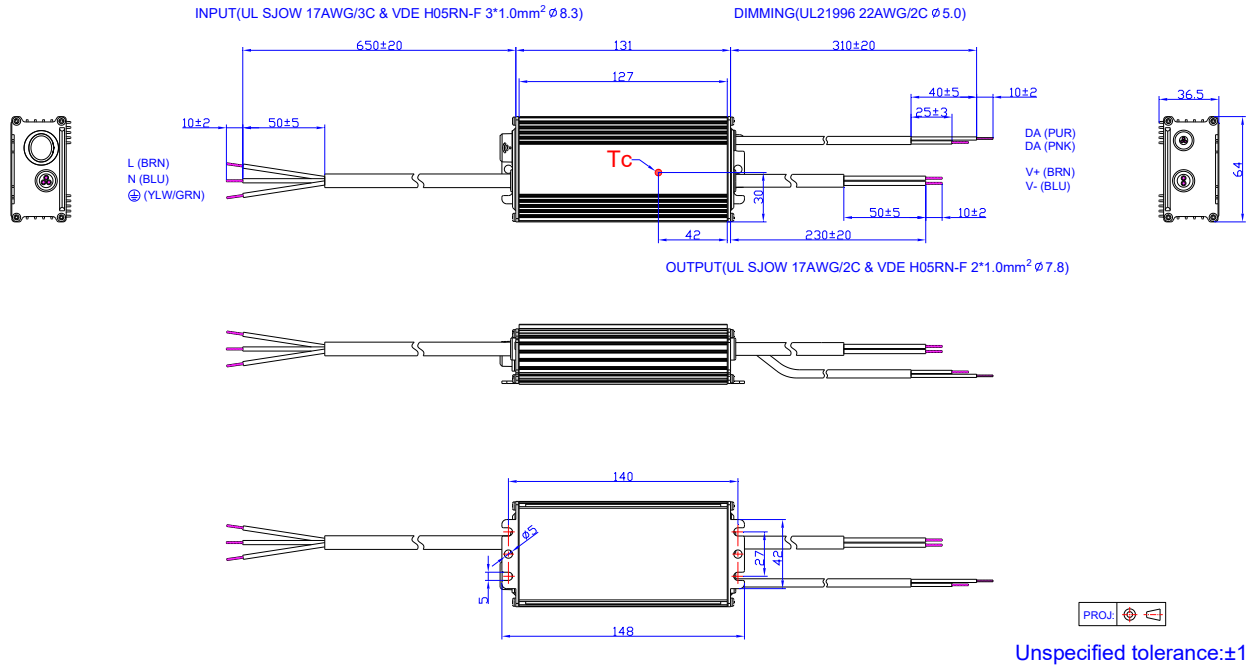

### EUM-100SxxxET

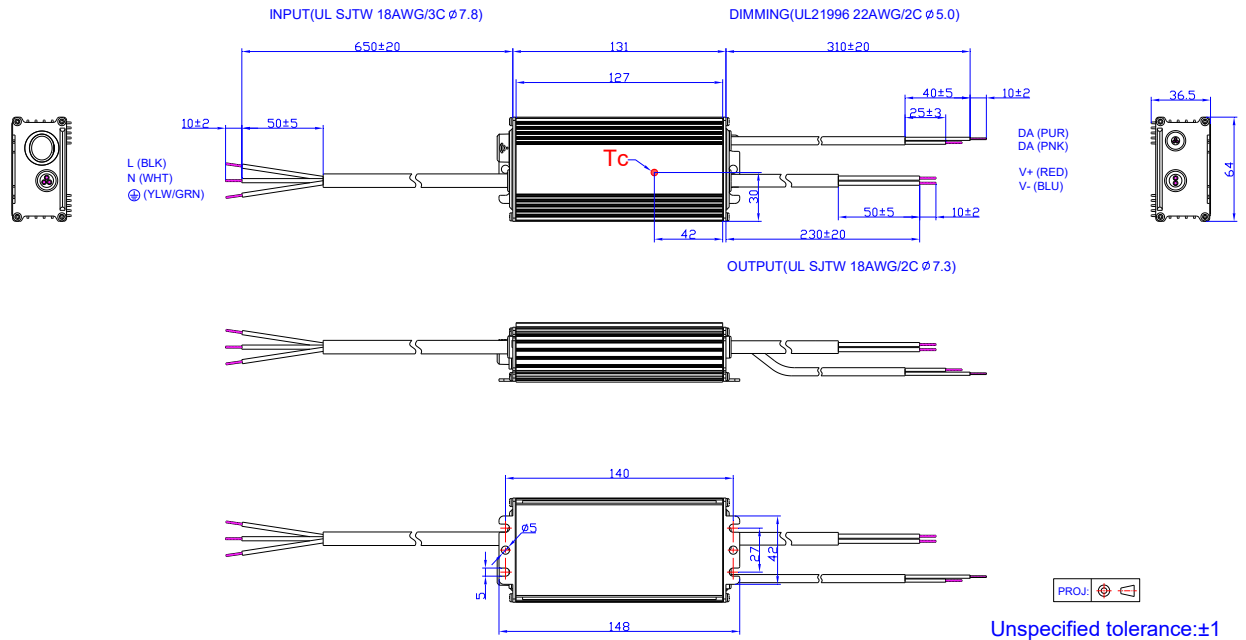

EUM-100SxxxEE

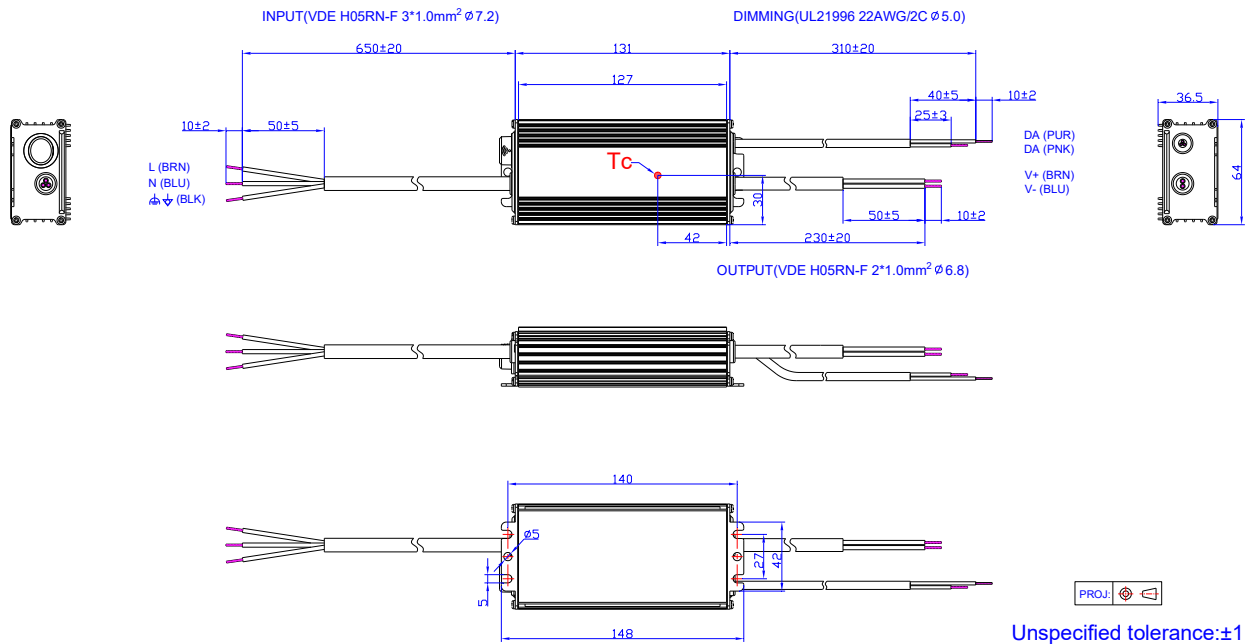

EUM-100SxxxEB

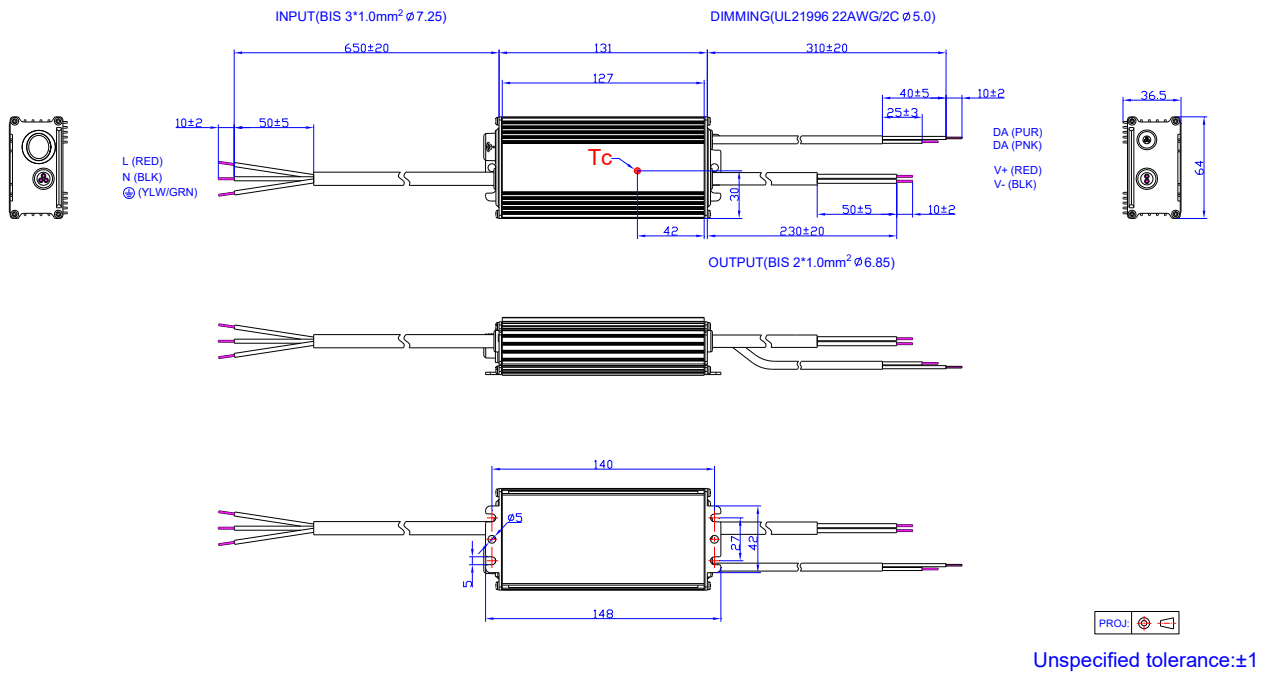

## RoHS Compliance

Our products comply with reference to RoHS Directive (EU) 2015/863 amending 2011/65/EU, calling for the elimination of lead and other hazardous substances from electronic products.

## Revision History

Change Date	Rev.	Description of Change		
		Item	From	To
2023-08-03	A	Datasheets Release	/	/
2024-01-20	B	Format	/	Updated
		BIS logo	/	Added
		Models	/	Updated
		Safety & EMC Compliance	/	Updated
		Inrush Current Waveform	/	Updated
		Dimming	/	Updated
		Mechanical Outline	/	Updated
2026-03-16	C	Product Photograph	/	Updated
		UKCA logo	/	Deleted
		global-mark logo	/	Added
		Safety & EMC Compliance	/	Updated
		Inrush Current Waveform	/	Updated