

## Features

- Ultra High Efficiency (Up to 91.5%)
- Full Power at Wide Output Current Range (Constant Power)
- Adjustable Output Current (AOC) with Programmability
- Isolated 0-10V/10V PWM/Resistor Dimmable
- Adjustable Dimming Curve
- Dim-to-Low-Voltage (DTLV) with Standby Power  $\leq 0.5W$
- Fade-Time Adjustable
- Output Lumen Compensation
- End-of-Life Indicator
- Input Surge Protection: DM 6kV, CM 10kV
- All-Around Protection: OVP, SCP, OTP
- IP65 and UL Dry/Damp Location
- TYPE HL, for Use in a Class I, Division 2 Hazardous (Classified) Location
- 5 Years Warranty



## Description

The SUM-110SxxxHF series is a 110W, constant-current, IP65 rated LED driver that operates from 90-305Vac input with excellent power factor. Created for many lighting applications including horticulture, high bay, etc. The high efficiency of this driver enables it to run cooler, significantly improving reliability and extending product life. To ensure trouble-free operation, protection is provided against input surge, output over voltage, short circuit, and over temperature.

## Models

Adjustable Output Current Range(mA)	Full-Power Current Range(mA) <sup>(1)</sup>	Default Output Current(mA)	Output Voltage Range(Vdc)	Max. Output Power(W)	Typical Efficiency <sup>(2)</sup>	Typical Power Factor		Model Number <sup>(3)</sup>
						120Vac	277Vac	
70-1050	700-1050	700	80-157	110	91.0%	0.99	0.96	SUM-110S105HF
195-2600	1950-2600	1950	30-56	110	90.5%	0.99	0.96	SUM-110S260HF <sup>(4)</sup>

- Notes:** (1) Output current range with constant power at 110W.  
 (2) Measured at 100% load and 220Vac input (see below "General Specifications" for details).  
 (3) Certified input voltage range: UL, FCC 100-277Vac; otherwise: 100-240Vac.  
 (4) SELV output.

## I-V Operation Area

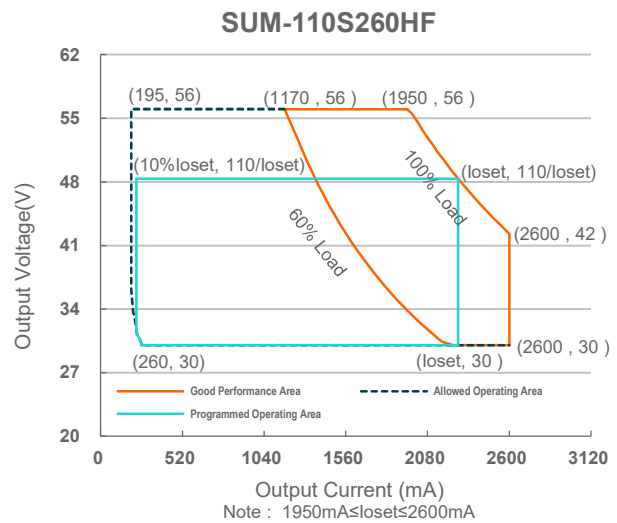
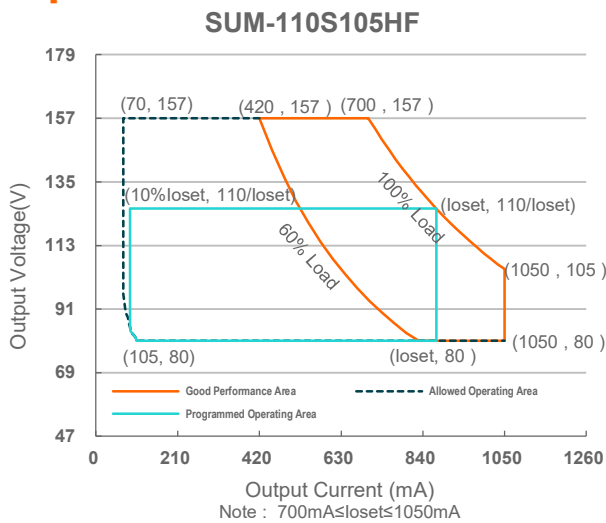

## Input Specifications

Parameter	Min.	Typ.	Max.	Notes
Input AC Voltage	90 Vac	-	305 Vac	
Input DC Voltage	127 Vdc	-	300 Vdc	
Input Frequency	47 Hz	-	63 Hz	
Leakage Current	-	-	0.75 MIU	UL 8750; 277Vac/ 60Hz
	-	-	0.70 mA	IEC 60598-1; 240Vac/ 60Hz
Input AC Current	-	-	1.18 A	Measured at 100% load and 120 Vac input.
	-	-	0.63 A	Measured at 100% load and 220 Vac input.
Inrush Current(I <sup>2</sup> t)	-	-	2.46 A <sup>2</sup> s	At 220Vac input, 25°C cold start, duration=228 μs, 10%I <sub>pk</sub> -10%I <sub>pk</sub> .
PF	0.9	-	-	At 100-277Vac, 50-60Hz, 60%-100% load (66-110W)
THD	-	-	20%	
THD	-	-	10%	At 220-240Vac, 50-60Hz, 75%-100% load (83-110W)

## Output Specifications

Parameter	Min.	Typ.	Max.	Notes
Output Current Tolerance	-5%loset	-	5%loset	At 100% load condition
Output Current Setting(I <sub>o</sub> set) Range				
SUM-110S105HF	70 mA	-	1050 mA	
SUM-110S260HF	195 mA	-	2600 mA	

## Output Specifications (Continued)

Parameter	Min.	Typ.	Max.	Notes
Output Current Setting Range with Constant Power SUM-110S105HF SUM-110S260HF	700 mA 1950 mA	- -	1050 mA 2600 mA	
Total Output Current Ripple (pk-pk)	-	5%I <sub>omax</sub>	10%I <sub>omax</sub>	At 100% load condition. 20 MHz BW
Output Current Ripple at < 200 Hz (pk-pk)	-	2%I <sub>omax</sub>	-	At 100% load condition. Only this component of ripple is associated with visible flicker.
Startup Overshoot Current	-	-	10%I <sub>omax</sub>	At 100% load condition
No Load Output Voltage SUM-110S105HF SUM-110S260HF	- -	- -	180 V 60 V	
Line Regulation	-	-	±0.5%	Measured at 100% load
Load Regulation	-	-	±3.0%	
Turn-on Delay Time	-	-	0.5 s	Measured at 120-277Vac input, 60%-100%load
Temperature Coefficient of I <sub>o</sub> set	-	0.03%/°C	-	Case temperature = 0°C ~T <sub>c</sub> max

## General Specifications

Parameter	Min.	Typ.	Max.	Notes
Efficiency at 120 Vac input: SUM-110S105HF I <sub>o</sub> =700 mA I <sub>o</sub> =1050 mA SUM-110S260HF I <sub>o</sub> =1950 mA I <sub>o</sub> =2600 mA	87.5% 87.5%	89.5% 89.5%	- -	Measured at 100% load and steady-state temperature in 25°C ambient; (Efficiency will be about 2.0% lower if measured immediately after startup.)
	86.5% 86.5%	88.5% 88.5%	- -	
Efficiency at 220 Vac input: SUM-110S105HF I <sub>o</sub> =700 mA I <sub>o</sub> =1050 mA SUM-110S260HF I <sub>o</sub> =1950 mA I <sub>o</sub> =2600 mA	89.0% 89.0%	91.0% 91.0%	- -	Measured at 100% load and steady-state temperature in 25°C ambient; (Efficiency will be about 2.0% lower if measured immediately after startup.)
	88.5% 88.5%	90.5% 90.5%	- -	
Efficiency at 277 Vac input: SUM-110S105HF I <sub>o</sub> =700 mA I <sub>o</sub> =1050 mA SUM-110S260HF I <sub>o</sub> =1950 mA I <sub>o</sub> =2600 mA	89.5% 89.5%	91.5% 91.5%	- -	Measured at 100% load and steady-state temperature in 25°C ambient; (Efficiency will be about 2.0% lower if measured immediately after startup.)
	89.0% 89.0%	91.0% 91.0%	- -	
Standby Power	-	-	0.5 W	Measured at 230Vac/50Hz; Dimming off
MTBF	-	297,000 Hours	-	Measured at 220Vac input, 80%load and 25°C ambient temperature (MIL-HDBK-217F)

## General Specifications (Continued)

Parameter	Min.	Typ.	Max.	Notes
Lifetime	-	120,000 Hours	-	Measured at 220Vac input, 80%load and 70°C case temperature; See lifetime vs. Tc curve for the details
	-	57,000 Hours	-	Measured at 120Vac input, 100%load and 40°C ambient temperature;
Operating Case Temperature for Safety Tc_s	-40°C	-	+90°C	
Operating Case Temperature for Warranty Tc_w	-40°C	-	+80°C	Case temperature for 5 years warranty Humidity: 10% RH to 95% RH;
Storage Temperature	-40°C	-	+85°C	Humidity: 5%RH to 95%RH
Dimensions Inches (L × W × H) Millimeters (L × W × H)	7.32 × 1.71 × 1.24 186 × 43.5 × 31.5			With mounting ear 8.27 × 1.71 × 1.24 210 × 43.5 × 31.5
Net Weight	-	550 g	-	

## Dimming Specifications

Parameter	Min.	Typ.	Max.	Notes
Absolute Maximum Voltage on the Vdim (+) Pin	-20 V	-	20 V	
Source Current on Vdim (+)Pin	90 μA	100 μA	110 μA	Vdim(+) = 0 V
Dimming Output Range	SUM-110S105HF	10%loset	-	700mA ≤ loiset ≤ 1050 mA
	SUM-110S260HF	10%loset	-	1950mA ≤ loiset ≤ 2600 mA
Dimming Output Range	SUM-110S105HF	70 mA	-	70 mA ≤ loiset ≤ 700 mA
	SUM-110S260HF	195 mA	-	195 mA ≤ loiset ≤ 1950 mA
Recommended Dimming Input Range	0 V	-	10 V	Default 0-10V dimming mode.
Dim off Voltage	0.35 V	0.5 V	0.65 V	
Dim on Voltage	0.55 V	0.7 V	0.85 V	
Hysteresis	-	0.2 V	-	
PWM_in High Level	-	10 V	-	
PWM_in Low Level	-	0 V	-	
PWM_in Frequency Range	200 Hz	-	3 KHz	
PWM_in Duty Cycle	0%	-	100%	
PWM Dimming off	3%	5%	8%	
PWM Dimming on	5%	7%	10%	
Hysteresis	-	2%	-	

## Safety & EMC Compliance

Safety Category	Standard
UL/CUL	UL 8750,CAN/CSA-C22.2 No. 250.13
CE	EN 61347-1, EN 61347-2-13
CB	IEC 61347-1, IEC 61347-2-13
KS	KS C 7655
EMI Standards	Notes
EN IEC 55015 <sup>(1)</sup>	Conducted emission Test & Radiated emission Test
EN IEC 61000-3-2	Harmonic current emissions
EN 61000-3-3	Voltage fluctuations & flicker
FCC Part 15 <sup>(1)</sup>	ANSI C63.4 Class B
	This device complies with Part 15 of the FCC Rules. Operation is subject to the following two conditions: [1] this device may not cause harmful interference, and [2] this device must accept any interference received, including interference that may cause undesired operation.
EMS Standards	Notes
EN 61000-4-2	Electrostatic Discharge (ESD): 8 kV air discharge, 4 kV contact discharge
EN 61000-4-3	Radio-Frequency Electromagnetic Field Susceptibility Test-RS
EN 61000-4-4	Electrical Fast Transient / Burst-EFT
EN 61000-4-5	Surge Immunity Test: AC Power Line: Differential Mode 6 kV, Common Mode 10 kV
EN 61000-4-6	Conducted Radio Frequency Disturbances Test-CS
EN 61000-4-8	Power Frequency Magnetic Field Test
EN 61000-4-11	Voltage Dips
EN 61547	Electromagnetic Immunity Requirements Applies To Lighting Equipment
ANSI Standards	Notes
ANSI C82.77-5	6kV combi-wave surge rating to comply with ANSI C82.77-5 CAT low

**Note:** (1) This LED driver meets the EMI specifications above, but EMI performance of a Luminaire that contains it depends also on the other devices connected to the driver and on the fixture itself.

## Derating

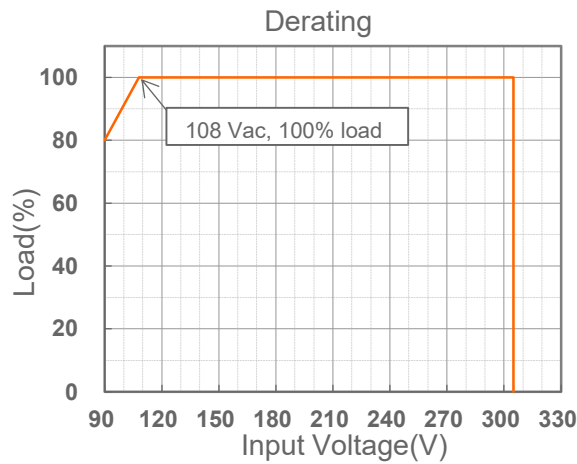

## Lifetime vs. Case Temperature

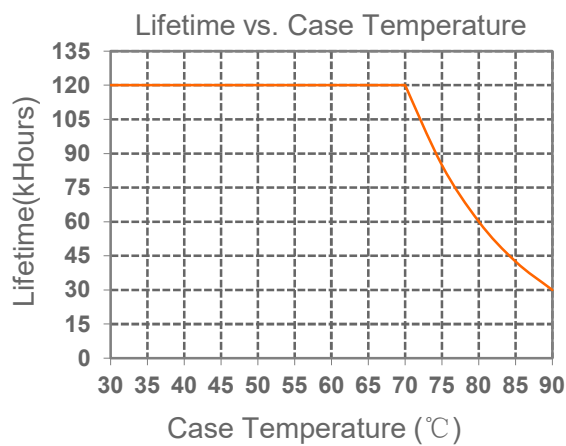

## Inrush Current Waveform

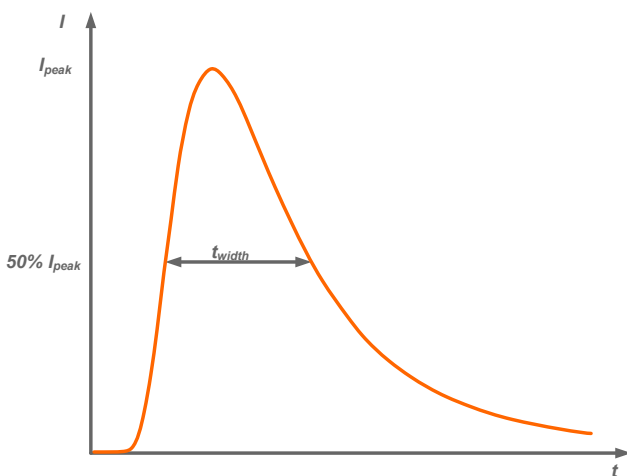

Input AC Voltage	$I_{peak}$	$t_{width}$ (@ 50% $I_{peak}$ )
220Vac	120A	104µs

## Efficiency vs. Load

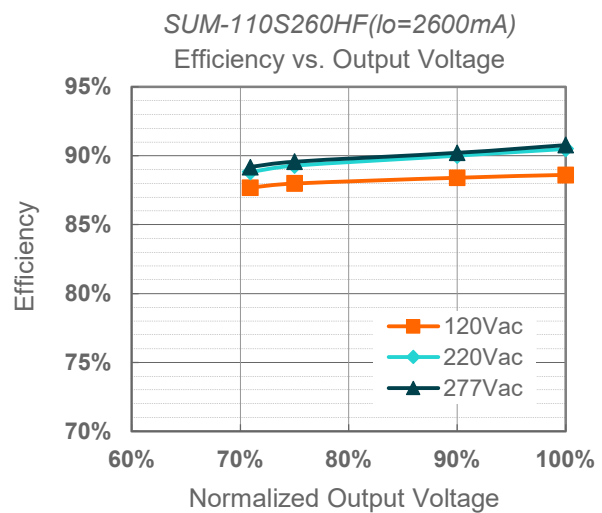
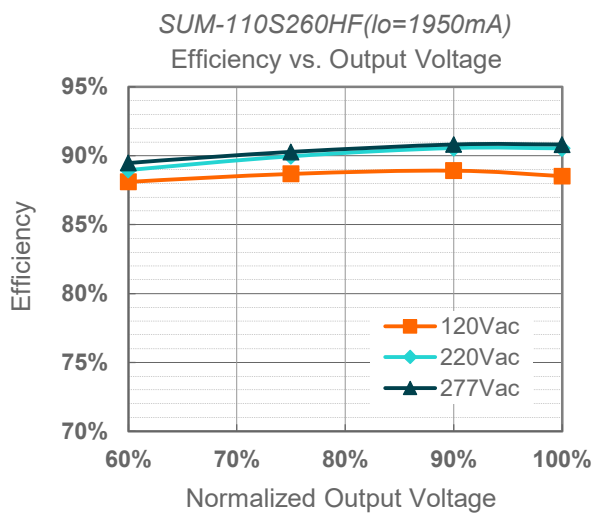
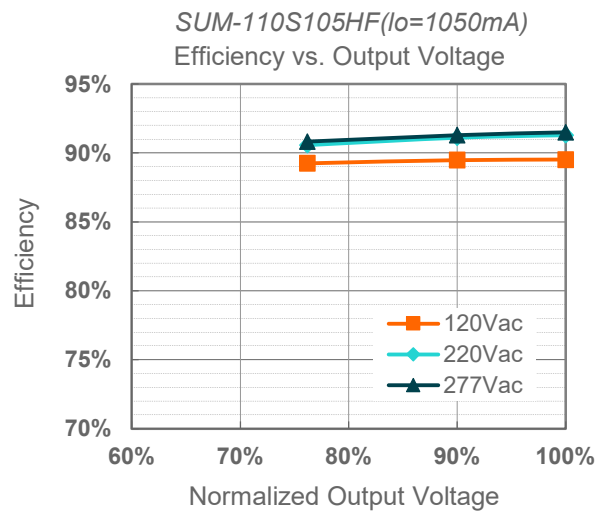
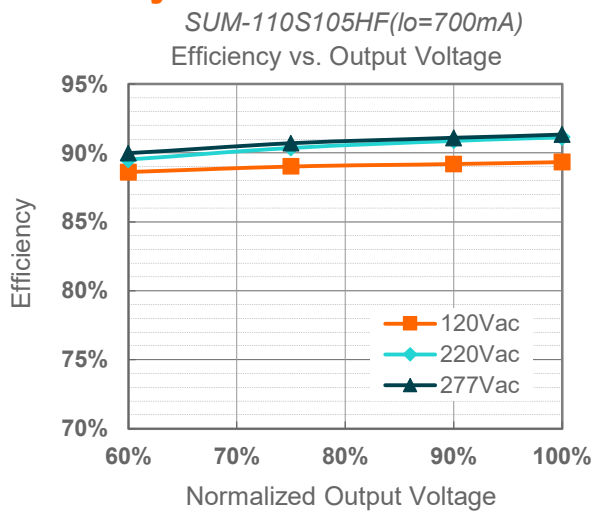

## Power Factor

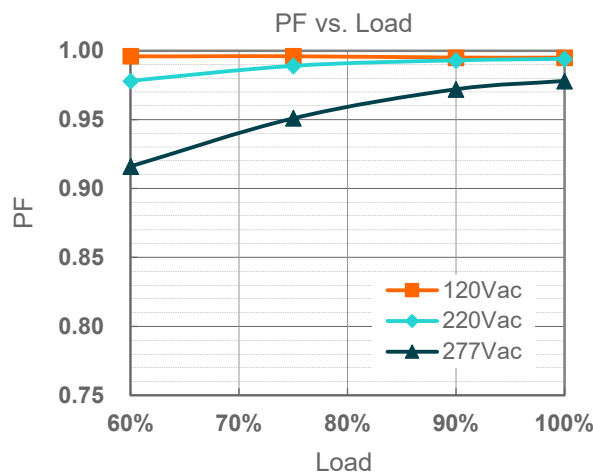

## Total Harmonic Distortion

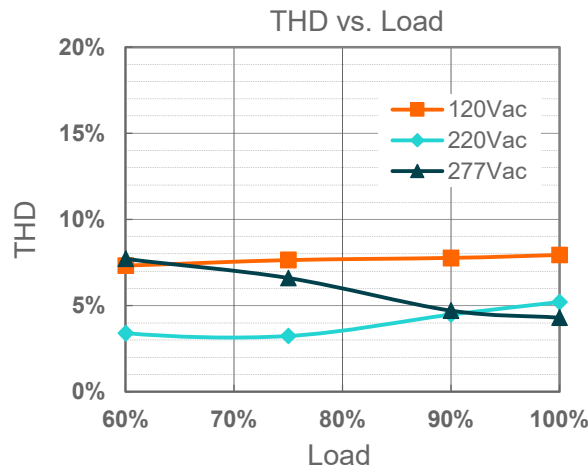

## Protection Functions

Parameter	Notes
Over Voltage Protection	Limits output voltage at no load and in case the normal voltage limit fails.
Short Circuit Protection	Auto Recovery. No damage will occur when any output is short circuited. The output shall return to normal when the fault condition is removed.
Over Temperature Protection	Decreases output current, returning to normal after over temperature is removed.

## Dimming

### ● 0-10V Dimming

The recommended implementation of the dimming control is provided below.

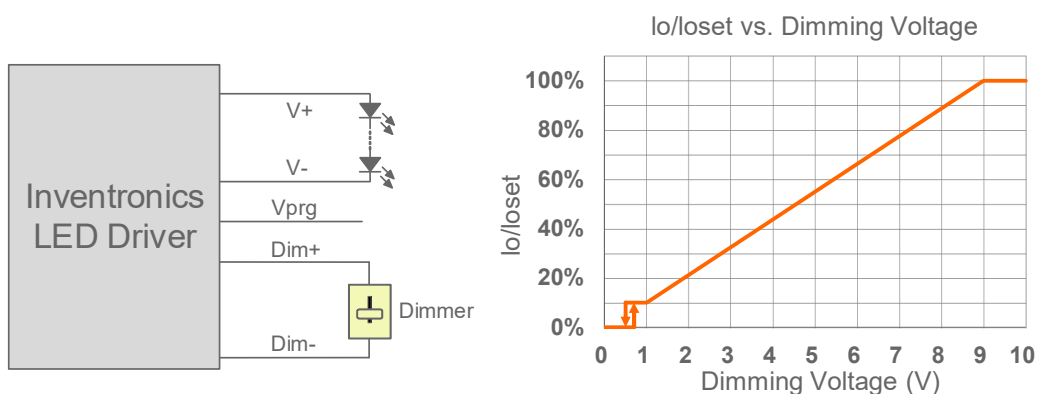

### Implementation 1: Positive logic

#### Notes:

1. Do NOT connect Dim- to the output V- or V+, otherwise the driver will not work properly.
2. The dimmer can also be replaced by an active 0-10V voltage source signal or passive components like zener.

## ● 10V PWM Dimming

The recommended implementation of the dimming control is provided below.

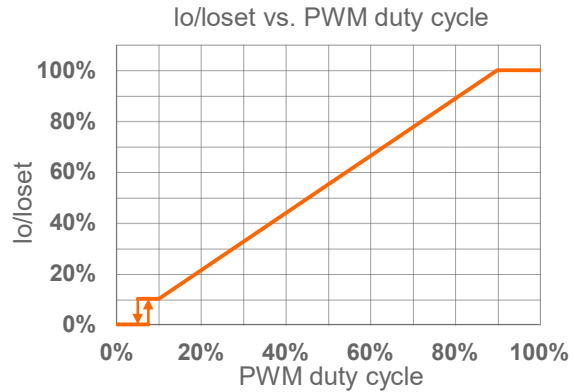
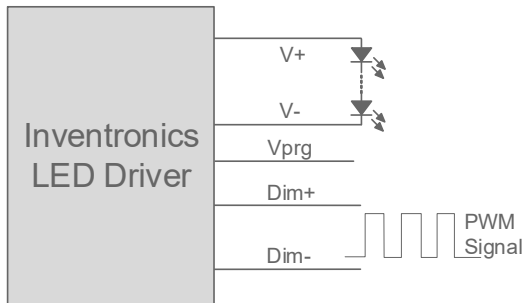

**Implementation 2: Positive logic**

**Notes:** Do NOT connect Dim- to the output V- or V+, otherwise the driver will not work properly.

## ● Resistor Dimming

The recommended implementation of the dimming control is provided below.

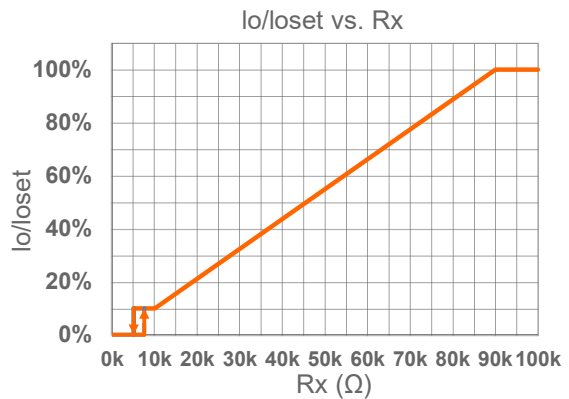
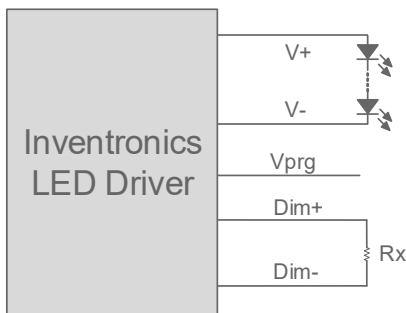

**Implementation 3: Positive logic**

**Notes:** Do NOT connect Dim- to the output V- or V+, otherwise the driver will not work properly.

## ● Adjustable Dimming Curve

0-10V, 10V PWM and resistor dimming curve can be set as corresponding dimming voltage by Inventronics Multi Programmer. Take the 0-10V positive logic dimming mode as an example, the recommended implementation of the dimming control is provided below.

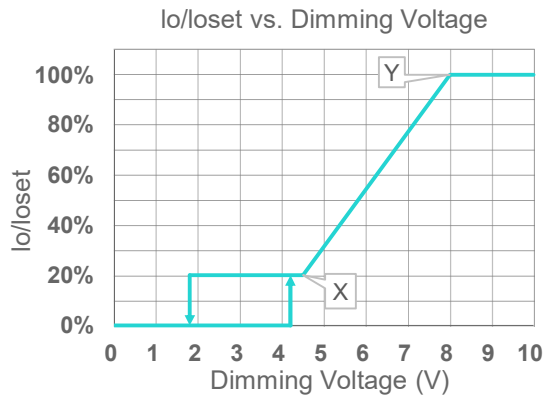
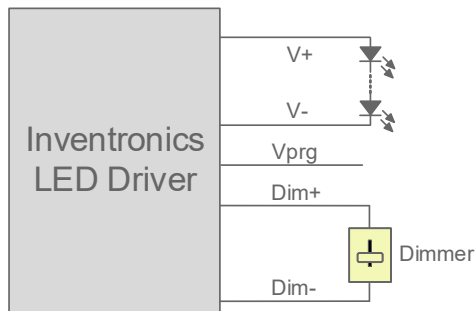

Implementation 4: Positive logic

### Notes:

1. Do NOT connect Dim- to the output V- or V+, otherwise the driver will not work properly.
2. The dimmer can also be replaced by an active 0-10V voltage source signal or passive components like zener.
3. When dimming voltage X point is set to be smaller than Y point, the dimming curve is positive logic, conversely, when X point is set to be bigger than Y point, the dimming curve is negative logic.

## ● Output Lumen Compensation

Output Lumen Compensation (OLC) may be used to maintain constant light output over the life of the LEDs by driving them at a reduced current when new, then gradually increasing the drive current over time to counteract LED lumen degradation.

## ● Fade Time Adjustable

Soft-start time and dimming slope can be adjusted by Inventronics Multi Programmer to get customized fade time experience, disable mode is default.

## ● End Of Life

End-of-Life (EOL) is providing a visual notification to a user that the LED module has reached the end of manufacturer-specified life and that the replacement is recommended. Once active, an indication is given at each power-up of the driver, which the driver indicates this through a lower light output during the first 1 minute before normal operation is continued.

## Programming Connection Diagram

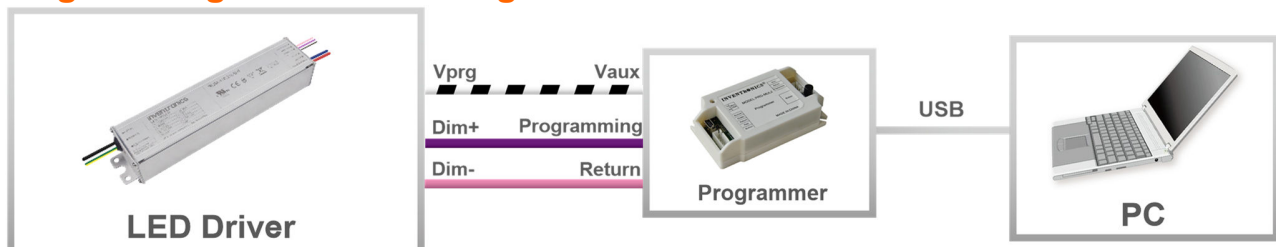

Note: The driver does not need to be powered on during the programming process.

- Please refer to [PRG-MUL2 \(Programmer\) datasheet for details.](#)

## Mechanical Outline

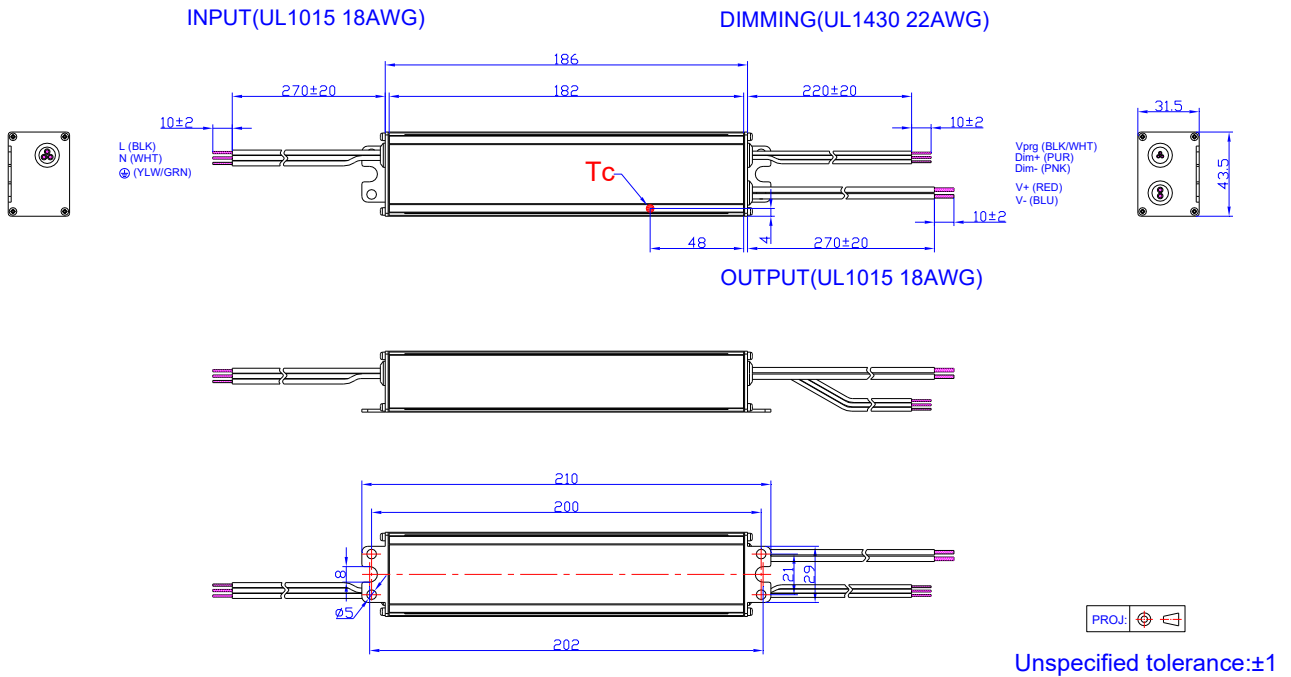

## RoHS Compliance

Our products comply with reference to RoHS Directive (EU) 2015/863 amending 2011/65/EU, calling for the elimination of lead and other hazardous substances from electronic products.

## Revision History

Change Date	Rev.	Description of Change		
		Item	From	To
2023-07-27	A	Datasheet Release	/	/
2026-04-03	B	Format	/	Updated
		Product photograph	/	Updated