

Features

- Full Power at Wide Output Current Range (Constant Power)
- Adjustable Output Current (AOC) with NFC
- DALI-2 Certified (Part 251, 252, 253)
- 3-Timer-Modes Dimmable
- Dim-to-Off with Standby Power $\leq 0.5W$
- Integrated Power Monitoring with High Accuracy up to $\pm 1\%$
- Output Lumen Compensation
- End-of-Life Indicator
- Input Surge Protection: DM 4kV, CM 6kV
- All-Around Protection: IUVP, IOVP, OVP, SCP, OTP
- IP66/IP67
UL Dry/Damp/Wet Location (ET/EG models)
- TYPE HL, for Use in a Class I, Division 2 Hazardous (Classified) Location (ET/EG models)
- Suitable for Luminaires with Protection Class I
- Suitable for Luminaires with Protection Class I and II (EE models)
- 5 Years Warranty

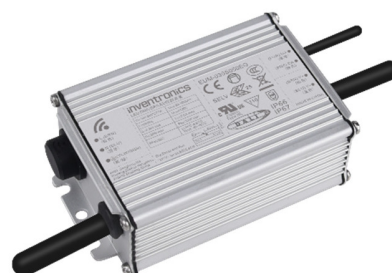

Description

The EUM-030SxxxEx series is a 30W, DALI-2 constant-current, NFC programmable and IP66/IP67 rated LED driver that operates from 90-305Vac input with excellent power factor. Created for intra-luminaire solutions and health monitoring applications, this family provides integrated AC power monitoring and dim-to-off functionality. The dimming control supports two-way communication via DALI-2. The high efficiency of these drivers and compact metal case enables them to run cooler, significantly improving reliability and extending product life. To ensure trouble-free operation, protection is provided against input surge, input under voltage, input over voltage, output over voltage, short circuit, and over temperature.

Models

Adjustable Output Current Range (mA)	Full-Power Current Range (mA) ⁽¹⁾	Default Output Current (mA)	Output Voltage Range (Vdc)	Max. Output Power (W)	Typical Efficiency ⁽²⁾	Typical Power Factor		Model Number ⁽³⁾⁽⁶⁾
						120Vac	220Vac	
30-500	300-500	350	30-100	30	90.0%	0.99	0.96	EUM-030S050Ex ⁽⁴⁾
55-1050	550-1050	700	17-54	30	87.5%	0.99	0.96	EUM-030S105Ex ⁽⁵⁾

- Notes:** (1) Output current range with constant power at 30W
 (2) Measured at 100% load and 220Vac input (see below "General Specifications" for details).
 (3) Certified input voltage range: UL, FCC 100-277Vac; otherwise 100-240Vac.
 (4) SELV Output.
 (5) Class 2 & SELV output.
 (6) x = G are UL Recognized, ENEC and CCC, etc. models; x = T are UL Class P models; x = E are Class II models with ENEC, etc. x = B are BIS models. See below "Mechanical Outline" for details.

I-V Operation Area

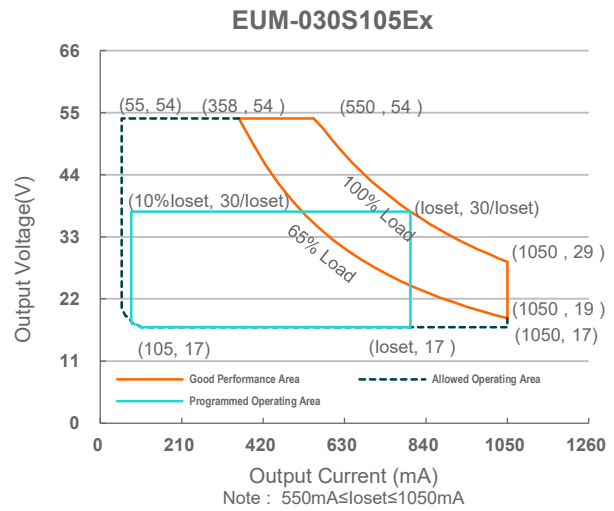
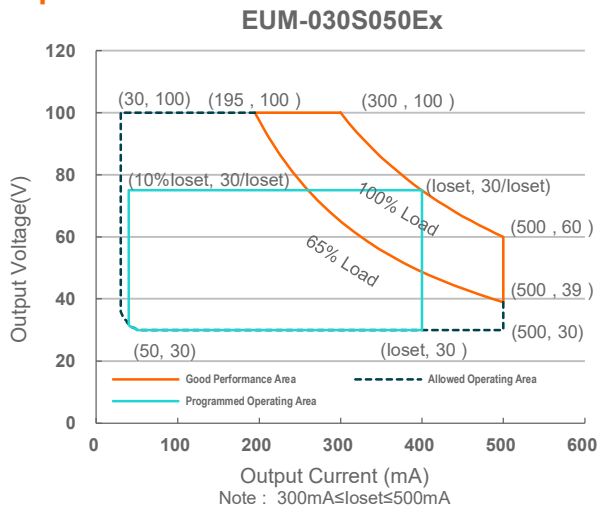

Input Specifications

Parameter	Min.	Typ.	Max.	Notes
Input AC Voltage	90 Vac	-	305 Vac	
Input DC Voltage	127 Vdc	-	300 Vdc	
Input Frequency	47 Hz	-	63 Hz	
Leakage Current	-	-	0.75 MIU	UL 8750; 277Vac/ 60Hz
	-	-	0.70 mA	IEC 60598-1; 240Vac/ 60Hz
Input AC Current	-	-	0.32 A	Measured at 100% load and 120 Vac input.
	-	-	0.17 A	Measured at 100% load and 220 Vac input.
Inrush Current(I ² t)	-	-	0.59 A ² s	At 220Vac input, 25°C cold start, duration=368 μs, 10%I _{pk} -10%I _{pk} .
PF	0.9	-	-	At 100-277Vac, 50-60Hz, 65%-100% load (19.5-30W)
THD	-	-	20%	
THD	-	-	10%	At 220-240Vac, 50-60Hz, 60%-100% load (18-30W)

Output Specifications

Parameter	Min.	Typ.	Max.	Notes
Output Current Tolerance	-5%loset	-	5%loset	At 100% load condition
Output Current Setting(I _o set) Range				
EUM-030S050Ex	30 mA	-	500 mA	
EUM-030S105Ex	55 mA	-	1050 mA	

Output Specifications (Continued)

Parameter	Min.	Typ.	Max.	Notes
Output Current Setting Range with Constant Power EUM-030S050Ex EUM-030S105Ex	300 mA 550 mA	- -	500 mA 1050 mA	
Total Output Current Ripple (pk-pk)	-	5%I _{omax}	10%I _{omax}	At 100% load condition. 20 MHz BW
Output Current Ripple at < 200 Hz (pk-pk)	-	2%I _{omax}	-	At 100% load condition. Only this component of ripple is associated with visible flicker.
Startup Overshoot Current	-	-	10%I _{omax}	At 100% load condition
No Load Output Voltage EUM-030S050Ex EUM-030S105Ex	- -	- -	120 V 60 V	
Line Regulation	-	-	±1%	Measured at 100% load
Load Regulation	-	-	±5%	
Turn-on Delay Time	-	-	0.5 s	Measured at all dimming modes except DALI-2, and 120-277Vac input, 65%-100% Load
	-	-	1.0 s	Measured at DALI-2 dimming mode, and 120-277Vac input, 65%-100% Load
Temperature Coefficient of I _o set	-	0.06%/°C	-	Case temperature = 0°C ~T _c max

General Specifications

Parameter	Min.	Typ.	Max.	Notes
Efficiency at 120 Vac input: EUM-030S050Ex I _o = 300 mA I _o = 500 mA EUM-030S105Ex I _o = 550 mA I _o = 1050 mA	85.5% 86.0%	87.5% 88.0%	- -	Measured at 100% load and steady-state temperature in 25°C ambient; (Efficiency will be about 2.0% lower if measured immediately after startup.)
Efficiency at 220 Vac input: EUM-030S050Ex I _o = 300 mA I _o = 500 mA EUM-030S105Ex I _o = 550 mA I _o = 1050 mA	87.0% 88.0%	89.0% 90.0%	- -	
Efficiency at 277 Vac input: EUM-030S050Ex I _o = 300 mA I _o = 500 mA EUM-030S105Ex I _o = 550 mA I _o = 1050 mA	88.0% 88.0%	90.0% 90.0%	- -	Measured at 100% load and steady-state temperature in 25°C ambient; (Efficiency will be about 2.0% lower if measured immediately after startup.)
Power Monitoring Accuracy	-1%	-	1%	
Standby Power	-	-	0.5 W	Measured at 230Vac/50Hz; Dimming off

General Specifications (Continued)

Parameter	Min.	Typ.	Max.	Notes
MTBF	-	547,000 Hours	-	Measured at 220Vac input, 80%Load and 25°C ambient temperature (MIL-HDBK-217F)
Lifetime	-	120,000 Hours	-	Measured at 220Vac input, 80%Load and 70°C case temperature; See lifetime vs. Tc curve for the details
Operating Case Temperature for Safety Tc_s	-40°C	-	+90°C	
Operating Case Temperature for Warranty Tc_w	-40°C	-	+80°C	Case temperature for 5 years warranty Humidity: 10% RH to 95% RH
Storage Temperature	-40°C	-	+85°C	Humidity: 5%RH to 95%RH
Dimensions Inches (L × W × H) Millimeters (L × W × H)	3.70 × 2.66 × 1.44 94 × 67.5 × 36.5			With mounting ear 4.41 × 2.66 × 1.44 112 × 67.5 × 36.5
Net Weight	-	510 g	-	

Dimming Specifications

Parameter	Min.	Typ.	Max.	Notes	
DA, DA High Level	9.5V	16V	22.5V		
DA, DA Low Level	-6.5V	0V	6.5V		
DA, DA Current	0mA	-	2mA		
Dimming Output Range	EUM-030S050Ex EUM-030S105Ex	10%loset	-	loset	300 mA ≤ loiset ≤ 500 mA 550 mA ≤ loiset ≤ 1050 mA
	EUM-030S050Ex EUM-030S105Ex	30 mA 55 mA	-	loset	30 mA ≤ loiset < 300 mA 55 mA ≤ loiset < 550 mA

Safety & EMC Compliance

Safety Category	Standard
UL/CUL	UL 8750,CAN/CSA-C22.2 No. 250.13
ENEC	EN 61347-1 ⁽¹⁾ , EN 61347-2-13
CE	EN 61347-1 ⁽¹⁾ , EN 61347-2-13 EN 301 489-1 EN 301 489-3 EN 300 330 EN 62479/EN 50663/EN 50665/EN 50364
CB	IEC 61347-1 ⁽¹⁾ , IEC 61347-2-13
CCC	GB 19510.1, GB 19510.14

Safety & EMC Compliance (Continued)

Safety Category	Standard
KS	KS C 7655
BIS	IS 15885(Part2/Sec13)
global-mark	AS/NZS 61347.1, AS/NZS 61347.2.13
Performance	Standard
ENEC	EN IEC 62384
EMI Standards	Notes
EN IEC 55015/GB/T 17743/KS C 9815 ⁽²⁾	Conducted emission Test & Radiated emission Test
EN IEC 61000-3-2/GB 17625.1	Harmonic current emissions
EN 61000-3-3	Voltage fluctuations & flicker
FCC Part 15 ⁽²⁾	ANSI C63.4 Class B This device complies with Part 15 of the FCC Rules. Operation is subject to the following two conditions: [1] this device may not cause harmful interference, and [2] this device must accept any interference received, including interference that may cause undesired Operation.
EMS Standards	Notes
EN 61000-4-2	Electrostatic Discharge (ESD): 8 kV air discharge, 4 kV contact discharge
EN 61000-4-3	Radio-Frequency Electromagnetic Field Susceptibility Test-RS
EN 61000-4-4	Electrical Fast Transient / Burst-EFT
EN 61000-4-5	Surge Immunity Test: AC Power Line: Differential Mode 4 kV, Common Mode 6 kV
EN 61000-4-6	Conducted Radio Frequency Disturbances Test-CS
EN 61000-4-8	Power Frequency Magnetic Field Test
EN 61000-4-11	Voltage Dips
EN 61547/KS C 9547	Electromagnetic Immunity Requirements Applies To Lighting Equipment
DALI-2 Standards	Notes
DALI-2 ⁽³⁾	IEC 62386-101, 102 & 207

Notes: (1) EE models meet the requirements for EN/IEC 61347-1(Class II), when the driver is energized, the allowed leakage current is perceptible but harmless.

(2) This LED driver meets the EMI specifications above, but EMI performance of a luminaire that contains it depends also on the other devices connected to the driver and on the fixture itself.

(3) DALI Parts: 101, 102, 207, 251, 252, 253.

Derating

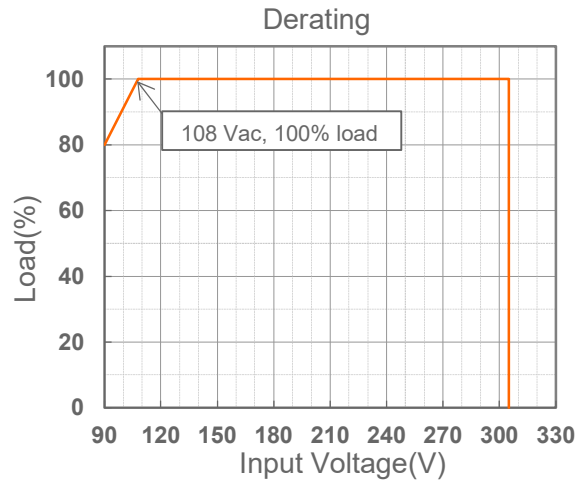

Lifetime vs. Case Temperature

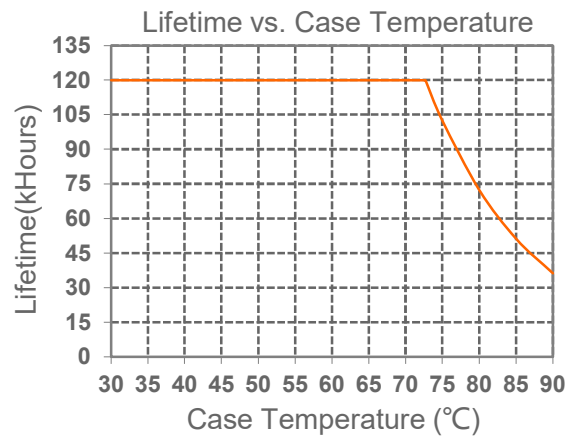

Inrush Current Waveform

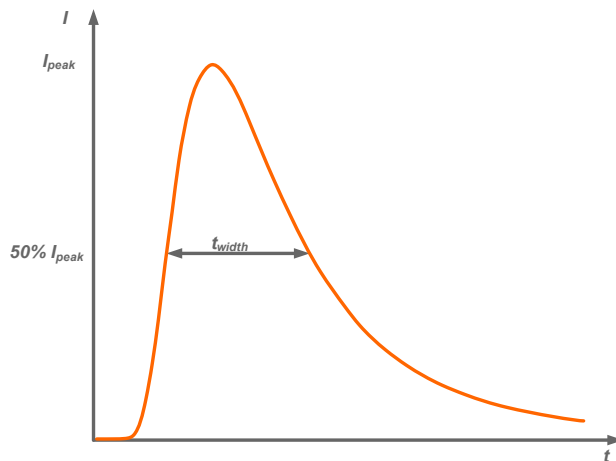

Input AC Voltage	I_{peak}	t_{width} (@ 50% I_{peak})
120 Vac	20.7 A	236 μs
220 Vac	40 A	292 μs
277 Vac	54 A	312 μs

Inrush Current Waveform (Continued)

MCB	Tripping Curves	B	B	B	B	C	C	C	C
	Rated Current	10A	16A	20A	25A	10A	16A	20A	25A
The Number of LED Driver can be Configured	120 Vac	18	29	37	46	24	39	49	61
	220 Vac	6	11	13	17	11	18	23	29
	277 Vac	4	7	9	11	7	12	15	19

Efficiency vs. Load

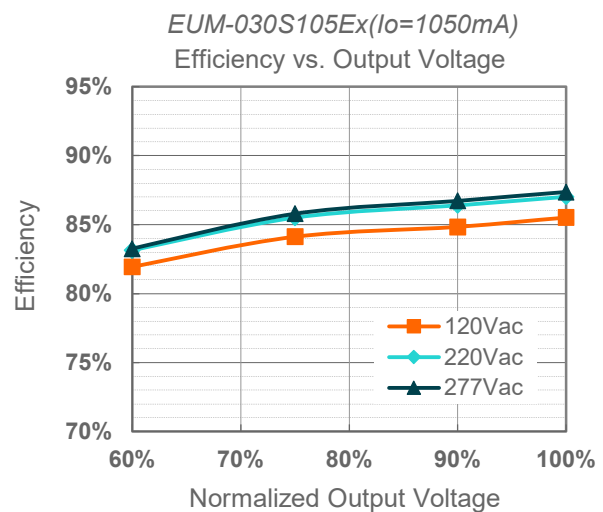
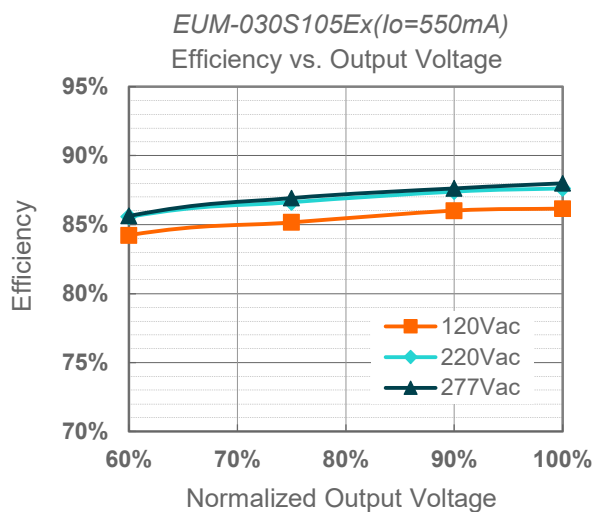
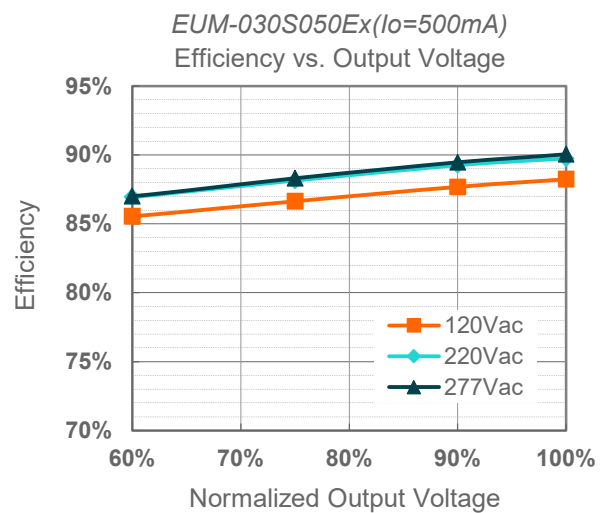
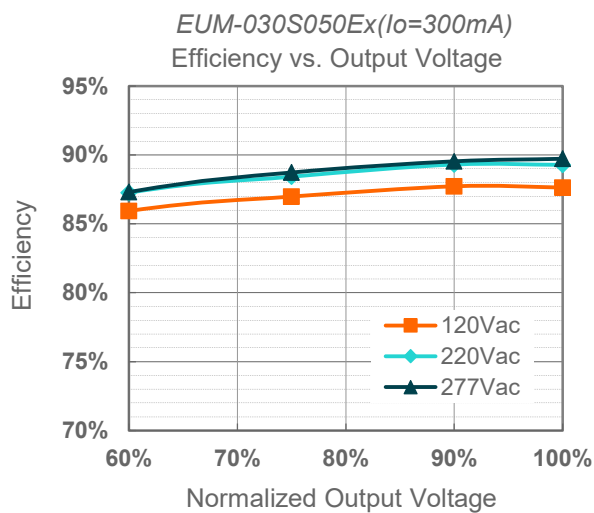

Power Factor

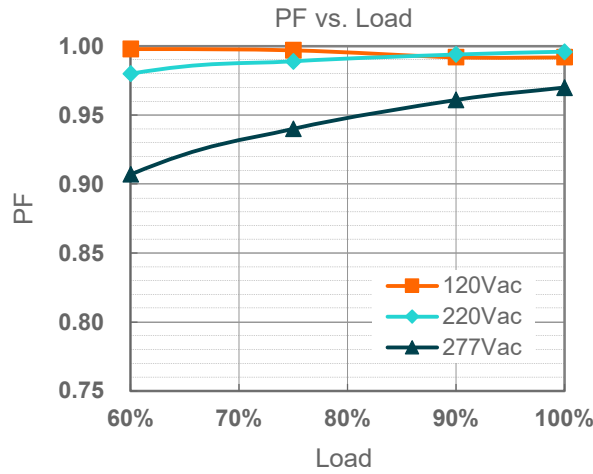

Total Harmonic Distortion

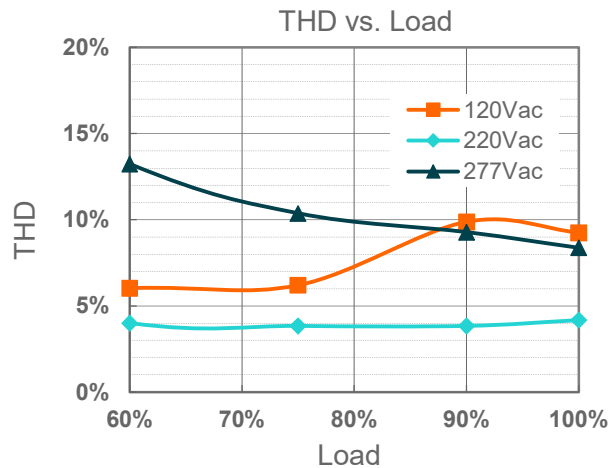

Protection Functions

Parameter		Min.	Typ.	Max.	Notes
Over Voltage Protection		Limits output voltage at no load and in case the normal voltage limit fails.			
Short Circuit Protection		Auto Recovery. No damage will occur when any output is short circuited. The output shall return to normal when the fault condition is removed.			
Over Temperature Protection		Decreases output current, returning to normal after over temperature is removed.			
Input Under Voltage Protection (IUVP)	Input Under Voltage Protection	70 Vac	80 Vac	90 Vac	Turn off the output when the input voltage falls below protection voltage.
	Input Under Voltage Recovery	75 Vac	85 Vac	95 Vac	Auto Recovery. The driver will restart when the input voltage exceeds recovery voltage.

Protection Functions (Continued)

Parameter		Min.	Typ.	Max.	Notes
Input Over Voltage Protection (IOVP)	Input Over Voltage Protection	310 Vac	320 Vac	330 Vac	Turn off the output when the input voltage exceeds protection voltage.
	Input Over Voltage Recovery	300 Vac	310 Vac	320 Vac	Auto Recovery. The driver will restart when the input voltage falls below recovery voltage.
	Max. of Input Over Voltage	-	-	350 Vac	The driver can survive stabilized input over voltage conditions up to 350Vac for a total of 8 hours.

● Input Under Voltage Protection Diagram

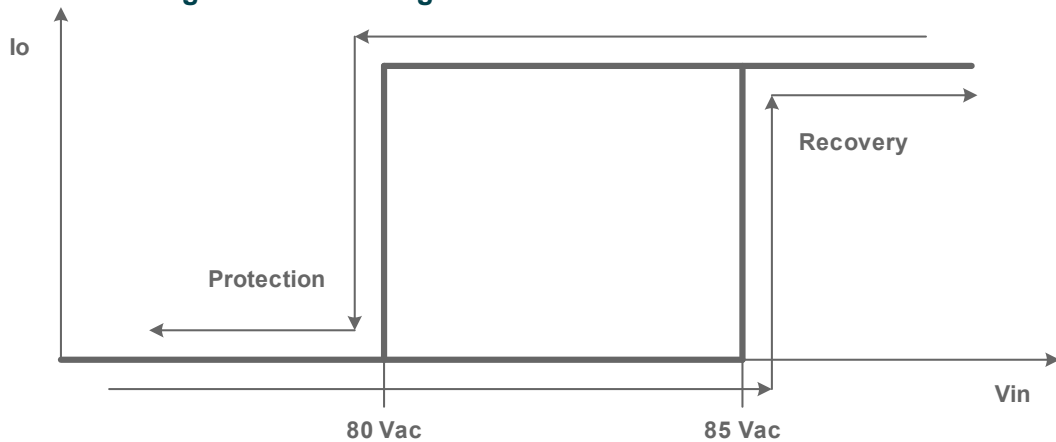

● Input Over Voltage Protection Diagram

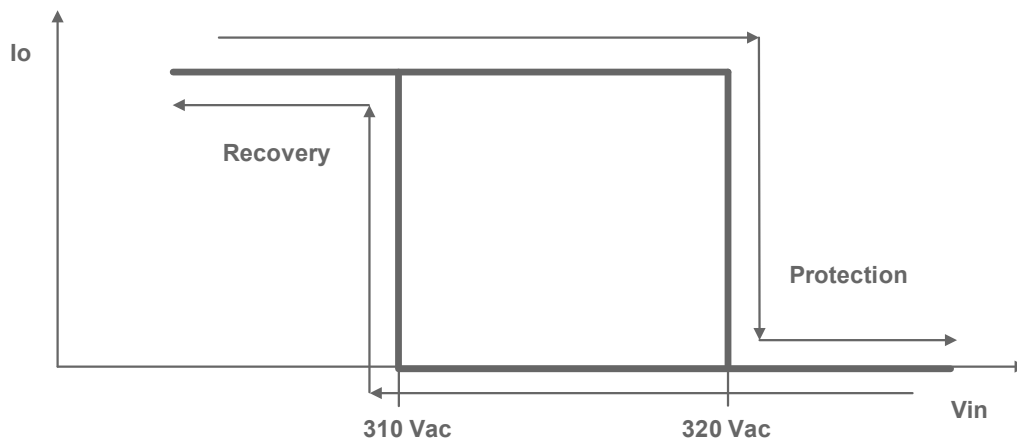

Dimming

● DALI-2 Dimming

The recommended implementation of the dimming control is provided below.

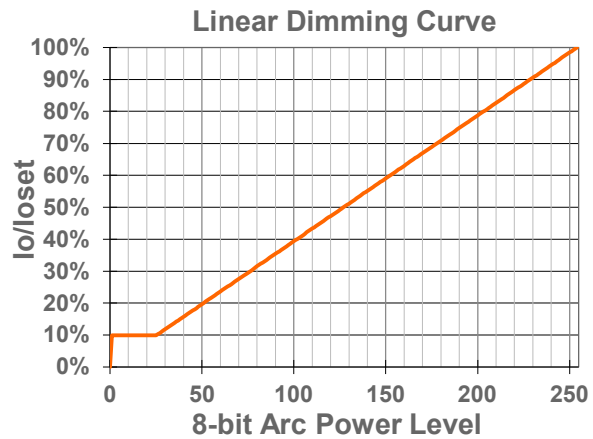
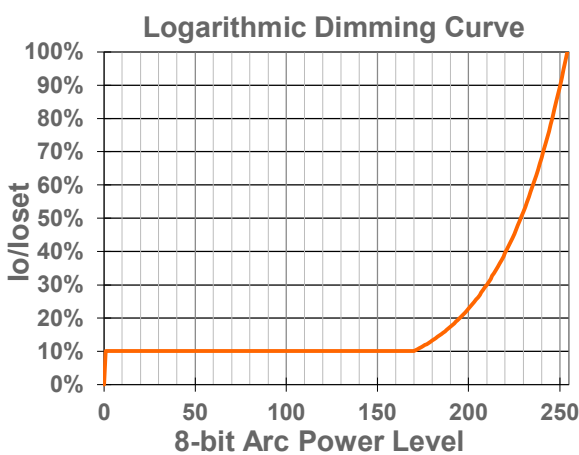
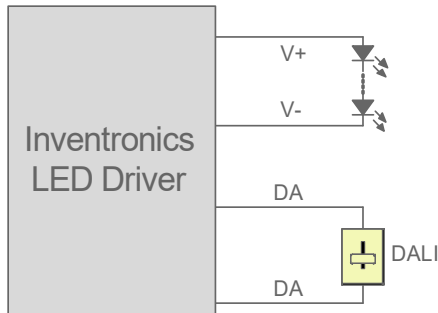

Implementation: DALI-2 Dimming

● Time Dimming

Time dimming control includes 3 kinds of modes, they are Self Adapting-Midnight, Self Adapting-Percentage and Traditional Timer.

- **Self Adapting-Midnight:** Automatically adjusts the dimming curve based on the on-time of past two days (if difference <15 minutes), assuming that the center point of the dimming curve is midnight local time.
- **Self Adapting-Percentage:** Automatically adjusts the on-time of each step by a constant percentage = (actual on-time for the past 2 days if difference <15 min) / (programmed on-time from the dimming curve).
- **Traditional Timer:** Follows the programmed timing curve after power on with no changes.

● Output Lumen Compensation

Output Lumen Compensation (OLC) may be used to maintain constant light output over the life of the LEDs by driving them at a reduced current when new, then gradually increasing the drive current over time to counteract LED lumen degradation.

● End Of Life

End-of-Life (EOL) is providing a visual notification to a user that the LED module has reached the end of manufacturer-specified life and that the replacement is recommended. Once active, an indication is given at each power-up of the driver, which the driver indicates this through a lower light output during the first 1 minute before normal operation is continued.

Programming Connection Diagram

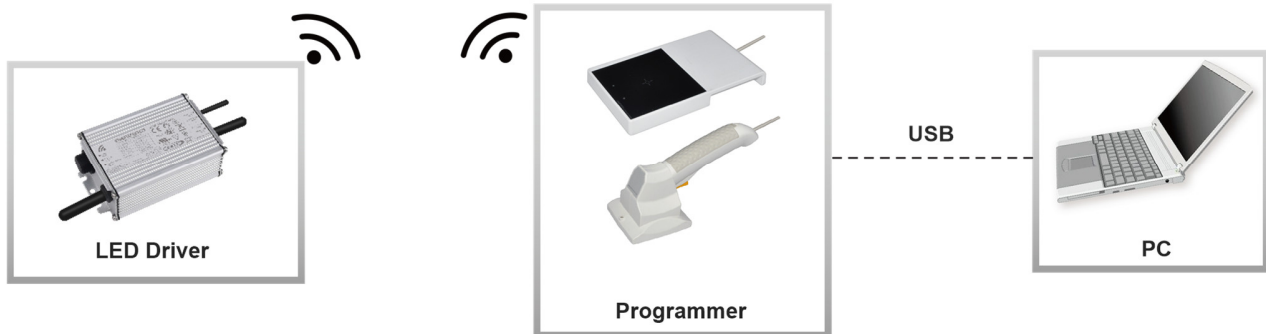

Note: The driver does not need to be powered on during the programming process.

● Please refer to [PRG-NFC-H](#) or [PRG-NFC-D2](#) (Programmer) datasheet for details.

Mechanical Outline

EUM-030SxxxEG

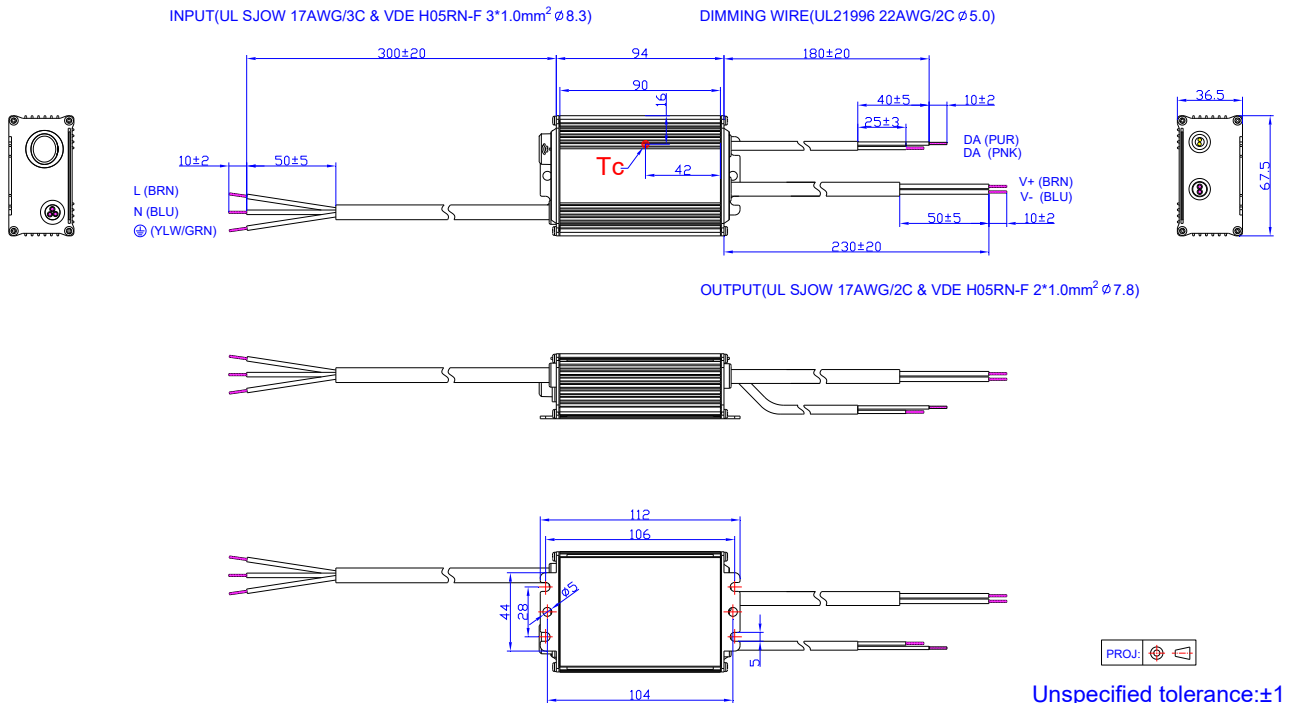

EUM-030SxxxET

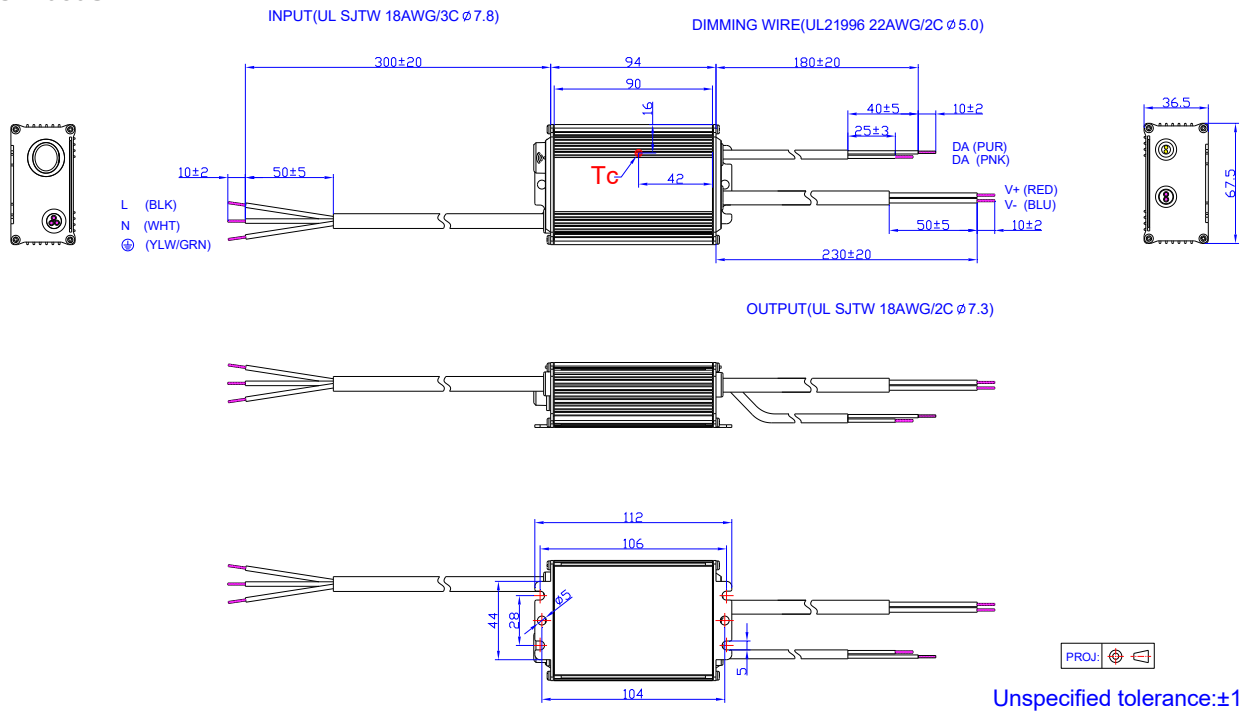

EUM-030SxxxEE

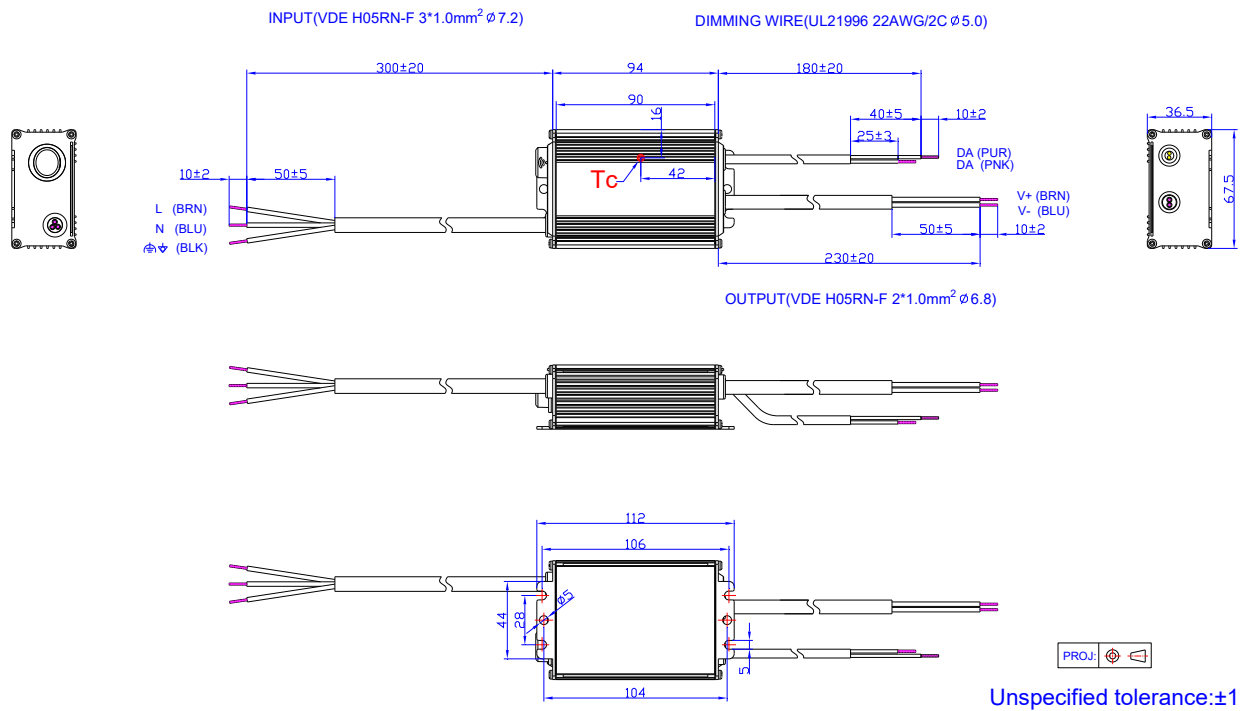

EUM-030SxxxEB

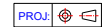
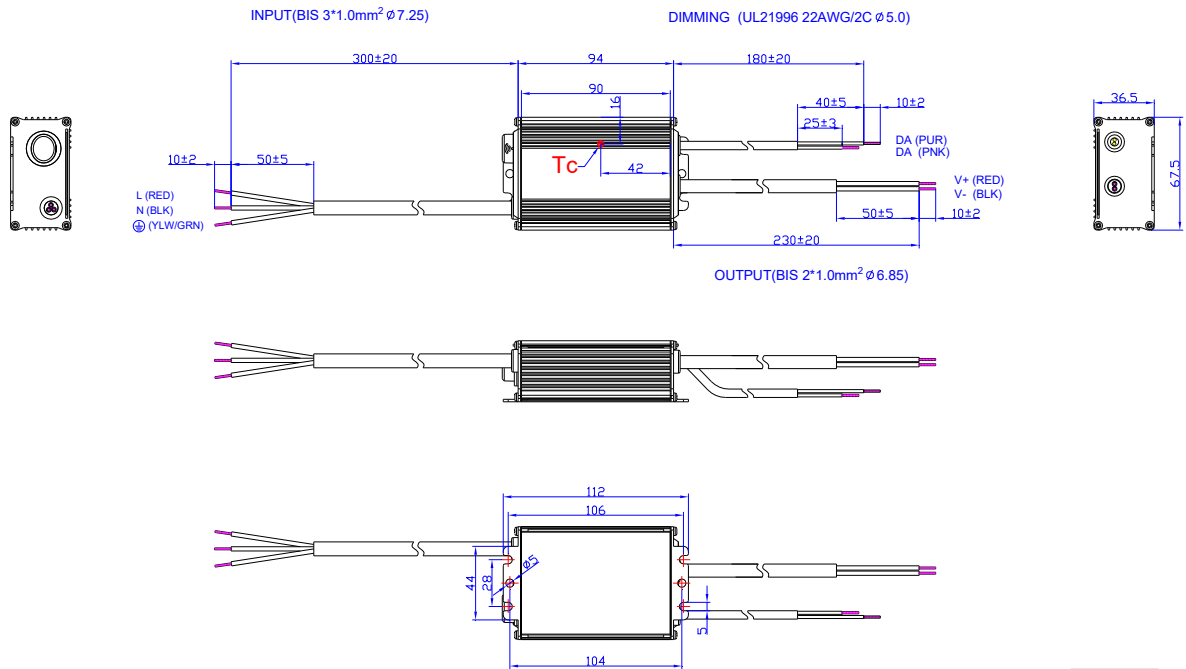

Unspecified tolerance: ±1

RoHS Compliance

Our products comply with reference to RoHS Directive (EU) 2015/863 amending 2011/65/EU, calling for the elimination of lead and other hazardous substances from electronic products.

Revision History

Change Date	Rev.	Description of Change		
		Item	From	To
2023-02-16	A	Datasheet Release	/	/
2024-01-20	B	Format	/	Updated
		BIS logo	/	Added
		Models	/	Updated
		Safety & EMC Compliance	/	Updated
		Inrush Current Waveform	/	Updated
		Dimming	/	Updated
		Mechanical Outline	/	Updated
2026-03-19	C	Product Photograph	/	Updated
		UKCA logo	/	Deleted
		KCC/global mark logo	/	Added
		Safety & EMC Compliance	/	Updated
		Inrush Current Waveform	/	Updated