

## Features

- Inventronics Patented Metal Case (Patent NO.: 202030323060.3)
- Full Power at Wide Output Current Range (Constant Power)
- Adjustable Output Current (AOC) with Potentiometer (Sx models)
- Adjustable Output Current (AOC) with Programmability (Dx models)
- 1-10V/10V PWM/3-Timer-Modes Dimmable (Only Dx models)
- Dim-to-Low-Voltage (DTLV) with Standby Power  $\leq 0.5W$  (Function Selectable)
- Input Surge Protection: DM 6kV, CM 6kV
- All-Around Protection: OVP, SCP, OTP
- IP65 and UL Dry/Damp/Wet Location
- SELV Output
- TYPE HL, for Use in a Class I, Division 2 Hazardous (Classified) Location
- 5 Year Warranty



## Description

The EUR-160SxxxDx(Sx) series is a 160W, constant-current, AOC LED driver that operates from 90-305 Vac input with excellent power factor. Created for many lighting applications including bay, etc. The high efficiency of these drivers and compact metal case enables them to run cooler, significantly improving reliability and extending product life. To ensure trouble-free operation, protection is provided against input surge, output over voltage, short circuit, and over temperature.

## Models

Adjustable Output Current Range	Full-Power Current Range(1)	Default Output Current	Input Voltage Range(2)	Output Voltage Range	Max. Output Power	Typical Efficiency (3)	Typical Power Factor		Model Number (4)(5)
							120Vac	220Vac	
300-4200mA	3000-4200mA	3300mA	90~305 Vac/ 127~300 Vdc	34~ 54Vdc	160 W	91.5%	0.99	0.96	EUR-160S420Dx
3000-4200mA	3000-4200mA	3300mA	90~305 Vac/ 127~300 Vdc	34~ 54Vdc	160 W	91.5%	0.99	0.96	EUR-160S420Sx

**Notes:** (1) Output current range with constant power at 160W.

(2) Certified input voltage range: UL, FCC 100-277Vac; otherwise 100-240Vac.

(3) Measured at 100% load and 220Vac input (see below "General Specifications" for details).

(4) SELV output.

(5) x = G are UL Recognized, ENEC and CCC, etc. models; x = T are UL Class P models.

## I-V Operation Area

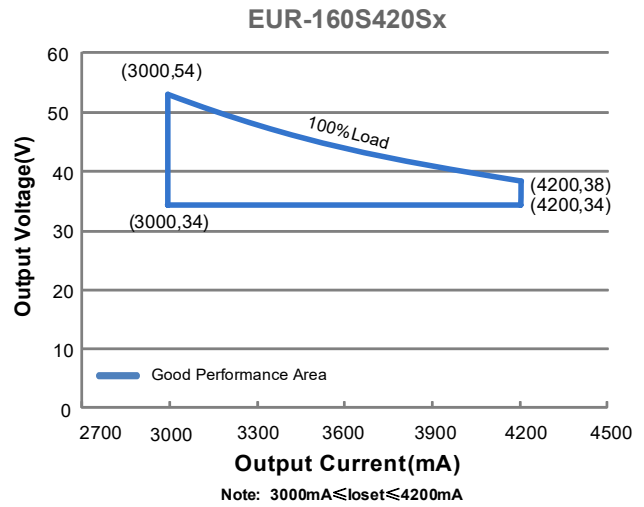
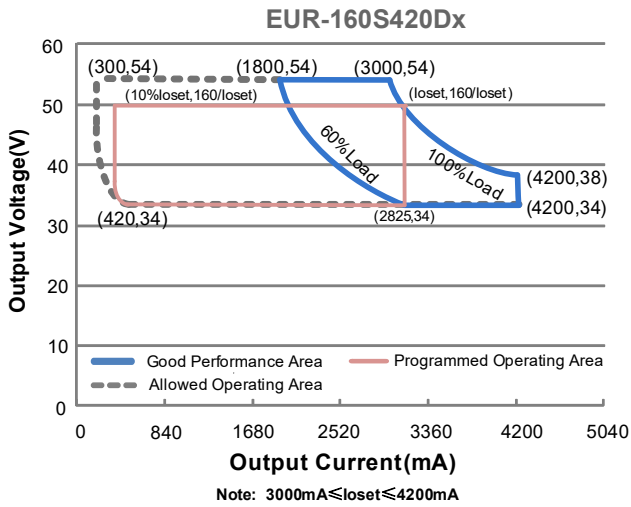

## Input Specifications

Parameter	Min.	Typ.	Max.	Notes
Input AC Voltage	90 Vac	-	305 Vac	
Input DC Voltage	127 Vdc	-	300 Vdc	
Input Frequency	47 Hz	-	63 Hz	
Leakage Current	-	-	0.75 MIU	UL 8750; 277Vac/60Hz
	-	-	0.70 mA	IEC 60598-1; 240Vac/60Hz
Input AC Current	-	-	1.70 A	Measured at 100% load and 120 Vac input.
	-	-	0.90 A	Measured at 100% load and 220 Vac input.
Inrush Current(I <sup>2</sup> t)	-	-	3.90 A <sup>2</sup> s	At 220Vac input, 25°C cold start, duration=252 μs, 10%Ipk-10%Ipk. See Inrush Current Waveform for the details.
PF	0.9	-	-	At 100-277Vac,50-60Hz, 60%-100% load (96-160W)
THD	-	-	20%	
THD	-	-	10%	At 220-240Vac,50-60Hz, 60%-100% load (96-160W)

## Output Specifications

Parameter	Min.	Typ.	Max.	Notes
Output Current Tolerance	-5%loset	-	5%loset	At 100% load condition
Output Current Setting(I <sub>load</sub> ) Range				
	EUR-160S420Dx	300 mA	-	4200mA
	EUR-160S420Sx	3000 mA	-	4200mA

## Output Specifications (Continued)

Parameter	Min.	Typ.	Max.	Notes
Output Current Setting Range with Constant Power EUR-160S420Dx EUR-160S420Sx	3000 mA 3000 mA	- -	4200mA 4200mA	
Total Output Current Ripple (pk-pk)	-	5%I <sub>o</sub> max	10%I <sub>o</sub> max	At 100% load condition. 20 MHz BW
Output Current Ripple at < 200 Hz (pk-pk)	-	2%I <sub>o</sub> max	-	At 100% load condition. Only this component of ripple is associated with visible flicker.
Startup Overshoot Current	-	-	10%I <sub>o</sub> max	At 100% load condition
No Load Output Voltage EUR-160S420Dx/Sx	-	-	60 V	
Line Regulation	-	-	±0.5%	Measured at 100% load
Load Regulation	-	-	±1.5%	
Turn-on Delay Time	-	-	0.5 s	Measured at 100-277Vac input, 60%-100% load
Temperature Coefficient of I <sub>o</sub> set	-	0.03%/°C	-	Case temperature = 0°C~T <sub>c</sub> max

## General Specifications

Parameter	Min.	Typ.	Max.	Notes
Efficiency at 120 Vac input: EUR-160S420Dx/Sx I <sub>o</sub> =3000 mA I <sub>o</sub> =4200 mA	87.5% 87.0%	89.5% 89.0%	- -	Measured at 100% load and steady-state temperature in 25°C ambient; (Efficiency will be about 2.0% lower if measured immediately after startup.)
Efficiency at 220 Vac input: EUR-160S420Dx/Sx I <sub>o</sub> =3000 mA I <sub>o</sub> =4200 mA	89.5% 89.0%	91.5% 91.0%	- -	Measured at 100% load and steady-state temperature in 25°C ambient; (Efficiency will be about 2.0% lower if measured immediately after startup.)
Efficiency at 277 Vac input: EUR-160S420Dx/Sx I <sub>o</sub> =3000 mA I <sub>o</sub> =4200 mA	90.0% 89.5%	92.0% 91.5%	- -	Measured at 100% load and steady-state temperature in 25°C ambient; (Efficiency will be about 2.0% lower if measured immediately after startup.)
MTBF	-	317,000 Hours	-	Measured at 220Vac input, 80%load and 25°C ambient temperature (MIL-HDBK-217F)
Lifetime	-	98,000 Hours	-	Measured at 220Vac input, 80%load and 70°C case temperature; See lifetime vs. T <sub>c</sub> curve for the details
Operating Case Temperature for Safety T <sub>c_s</sub>	-40°C	-	+90°C	
Operating Case Temperature for Warranty T <sub>c_w</sub>	-40°C	-	+80°C	Case temperature for 5 years warranty Humidity: 10% RH to 95% RH;
Storage Temperature	-40°C	-	+85°C	Humidity: 5% RH to 95% RH;
Dimensions Inches (Ø × H) Millimeters (Ø × H)		Ø 5.12 x 2.44 Ø 130 x 62		
Net Weight	-	1000 g	-	

## Dimming Specifications

Parameter	Min.	Typ.	Max.	Notes
Absolute Maximum Voltage on the Vdim (+) Pin	-20 V	-	20 V	
Source Current on Vdim (+)Pin	200 $\mu$ A	300 $\mu$ A	450 $\mu$ A	Vdim(+) = 0 V
Dimming Output Range	10%loset	-	loset	3000 mA $\leq$ loset $\leq$ 4200 mA
	300 mA	-	loset	300 mA $\leq$ loset < 3000 mA
Recommended Dimming Input Range	0 V	-	10 V	Default is without DTLV and need to set DTLV function in Inventronics Programming Software.
DTLV Voltage	0.35 V	0.5 V	0.65 V	
Dim on Voltage	0.55 V	0.7 V	0.85 V	
Hysteresis	-	0.2 V	-	
PWM_in High Level	-	10 V	-	
PWM_in Low Level	-	0 V	-	
PWM_in Frequency Range	200 Hz	-	2 KHz	
PWM_in Duty Cycle	0%	-	100%	
PWM DTLV	3%	5%	8%	
PWM Dimming on	5%	7%	10%	
Hysteresis	-	2%	-	

## Safety & EMC Compliance

Safety Category	Standard
UL/CUL	UL 8750,CAN/CSA-C22.2 No. 250.13
CE	EN 61347-1, EN 61347-2-13
CB	IEC 61347-1, IEC 61347-2-13
CCC	GB 19510.1, GB 19510.14
KS	KS C 7655
PSE-2	J 61347-1, J 61347-2-13, J55015
EMI Standards	Notes
EN IEC 55015/GB/T 17743 <sup>(1)</sup>	Conducted emission Test &Radiated emission Test
EN IEC 61000-3-2/GB 17625.1	Harmonic current emissions
EN 61000-3-3	Voltage fluctuations & flicker

## Safety & EMC Compliance (Continued)

EMI Standards	Notes
FCC Part 15 <sup>(1)</sup>	ANSI C63.4 Class B This device complies with Part 15 of the FCC Rules. Operation is subject to the following two conditions: [1] this device may not cause harmful interference, and [2] this device must accept any interference received, including interference that may cause undesired operation.
EMS Standards	Notes
EN 61000-4-2	Electrostatic Discharge (ESD): 8 kV air discharge, 4 kV contact discharge
EN 61000-4-3	Radio-Frequency Electromagnetic Field Susceptibility Test-RS
EN 61000-4-4	Electrical Fast Transient / Burst-EFT
EN 61000-4-5	Surge Immunity Test: AC Power Line: Differential Mode 6 kV, Common Mode 6 kV
EN 61000-4-6	Conducted Radio Frequency Disturbances Test-CS
EN 61000-4-8	Power Frequency Magnetic Field Test
EN 61000-4-11	Voltage Dips
EN 61547	Electromagnetic Immunity Requirements Applies To Lighting Equipment
ANSI Standards	Notes
ANSI C82.77-5	6kV combi-wave surge rating to comply with ANSI C82.77-5 CAT low

**Note:** (1) This LED driver meets the EMI specifications above, but EMI performance of a luminaire that contains it depends also on the other devices connected to the driver and on the fixture itself.

## Derating

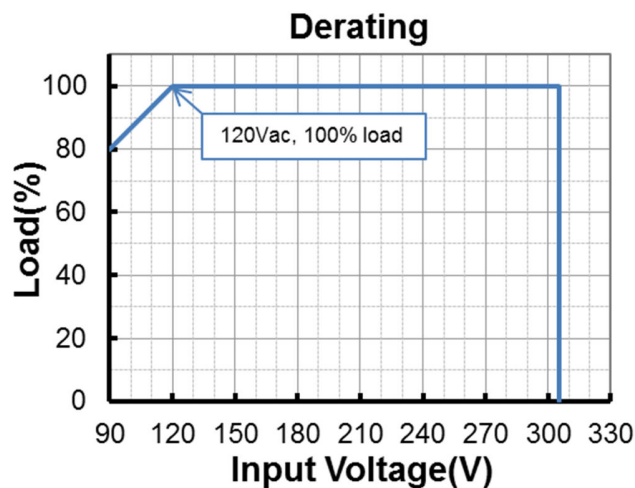

## Lifetime vs. Case Temperature

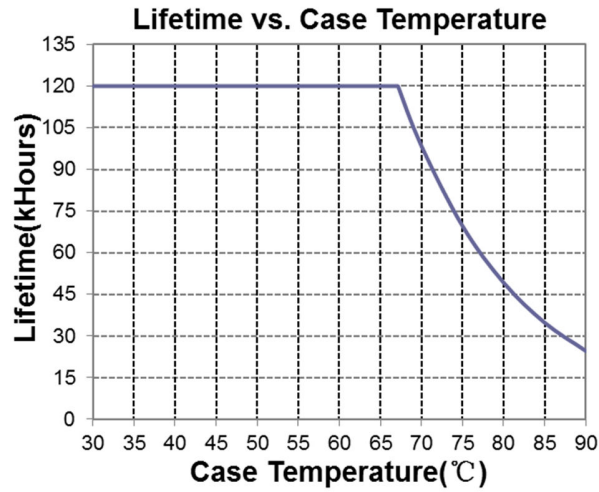

## Inrush Current Waveform

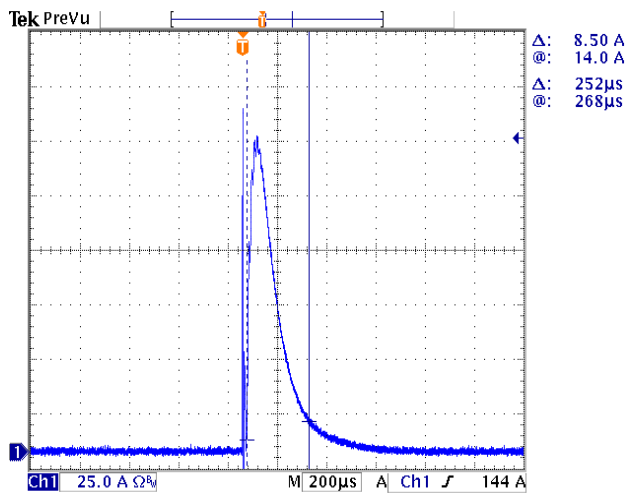

## Efficiency vs. Load

EUR-160S420Dx(Sx) (Io=3000mA)  
**Efficiency vs. Output Voltage**

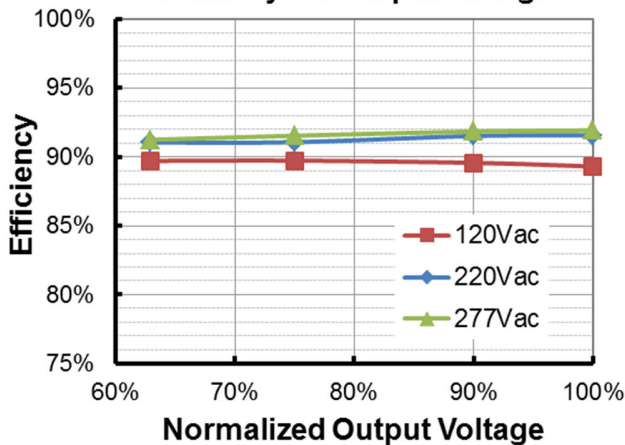

EUR-160S420Dx(Sx) (Io=4200mA)  
**Efficiency vs. Output Voltage**

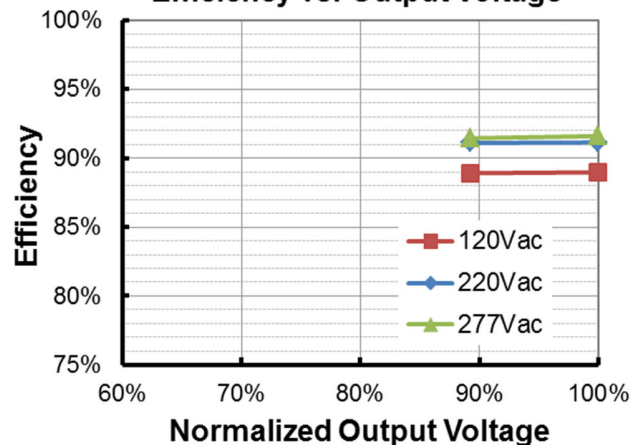

## Power Factor

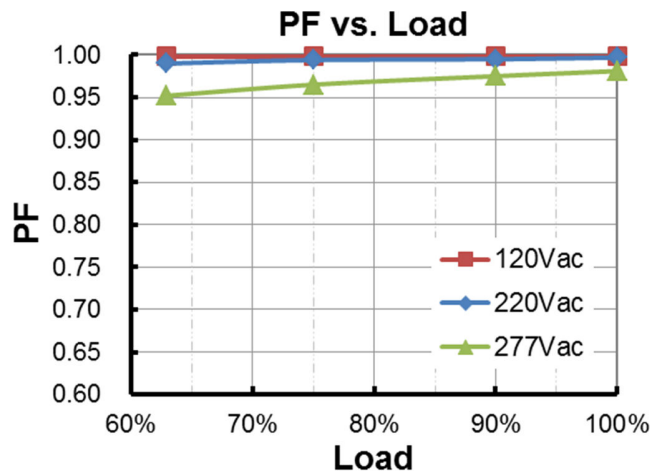

## Total Harmonic Distortion

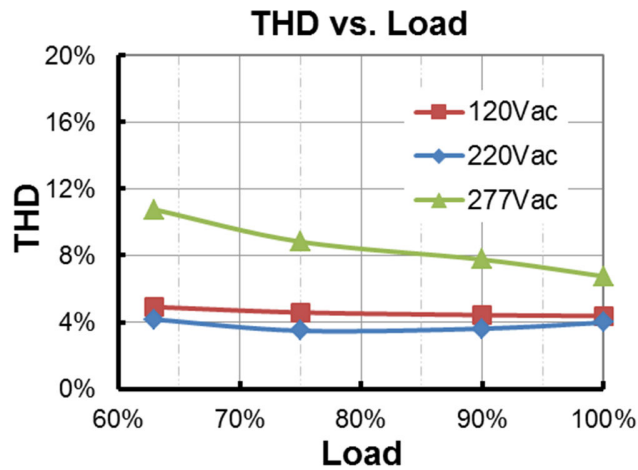

## Protection Functions

Parameter	Notes
Over Voltage Protection	Limits output voltage at no load and in case the normal voltage limit fails.
Short Circuit Protection	Auto Recovery. No damage will occur when any output is short circuited. The output shall return to normal when the fault condition is removed.
Over Temperature Protection	Decreases output current. Returning to normal after over temperature is removed.

## Dimming

### ● 1-10V Dimming

The recommended implementation of the dimming control is provided below.

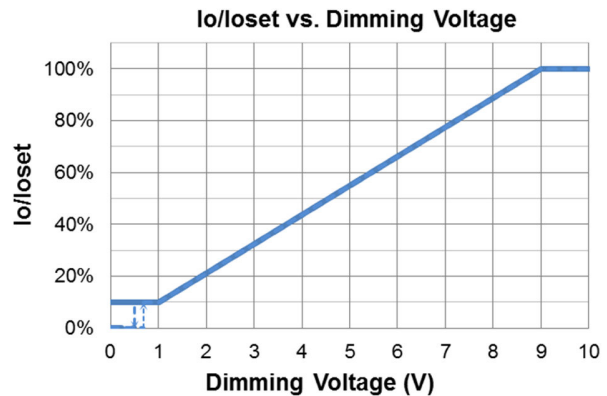
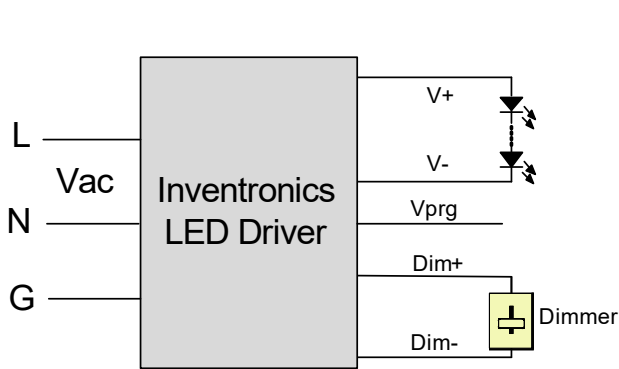

Implementation 1: DC Input

**Notes:**

1. Do NOT connect Dim- to the output V- or V+, otherwise the driver will not work properly.
2. The dimmer can also be replaced by an active 1-10V voltage source signal or passive components like zener.

### ● 10V PWM Dimming

The recommended implementation of the dimming control is provided below.

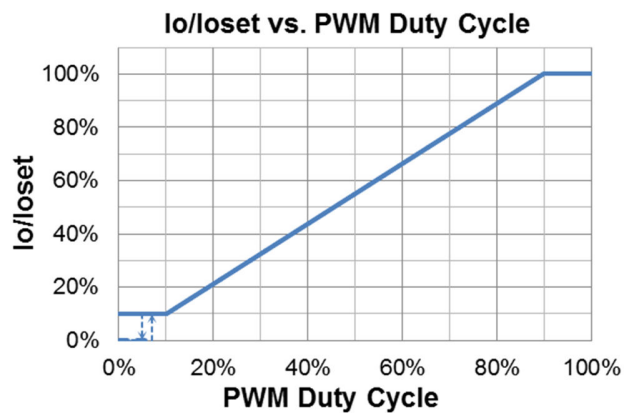
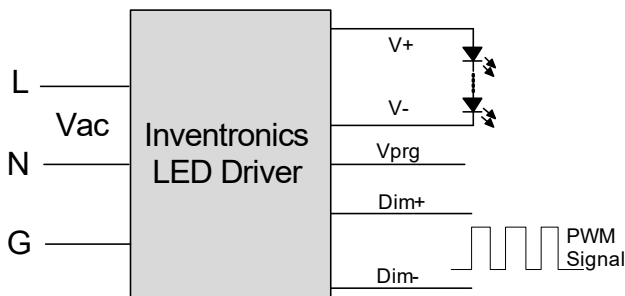

Implementation 2: Positive logic

**Note:**

1. Do NOT connect Dim- to the output V- or V+, otherwise the driver will not work properly.

### ● Time Dimming

Time dimming control includes 3 kinds of modes, they are Self Adapting-Midnight, Self Adapting-Percentage and Traditional Timer.

- **Self Adapting-Midnight:** Automatically adjusts the dimming curve based on the on-time of past two days (if difference <15 minutes), assuming that the center point of the dimming curve is midnight local time.
- **Self Adapting-Percentage:** Automatically adjusts the on-time of each step by a constant percentage = (actual on-time for the past 2 days if difference <15 min) / (programmed on-time from the dimming curve).
- **Traditional Timer:** Follows the programmed timing curve after power on with no changes.

## Programming Connection Diagram

EUR-160S420DG

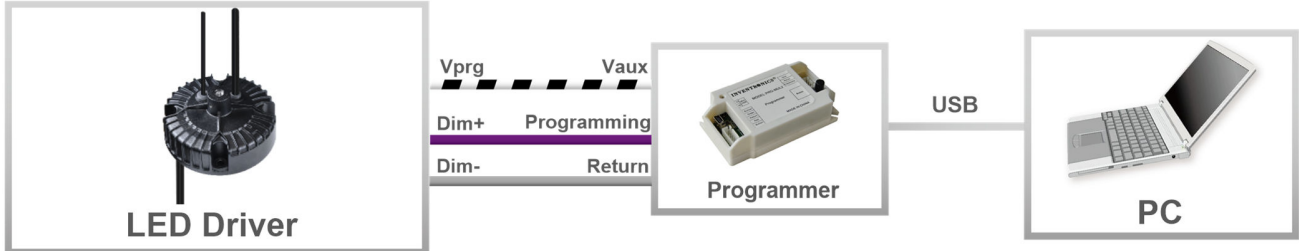

EUR-160S420DT

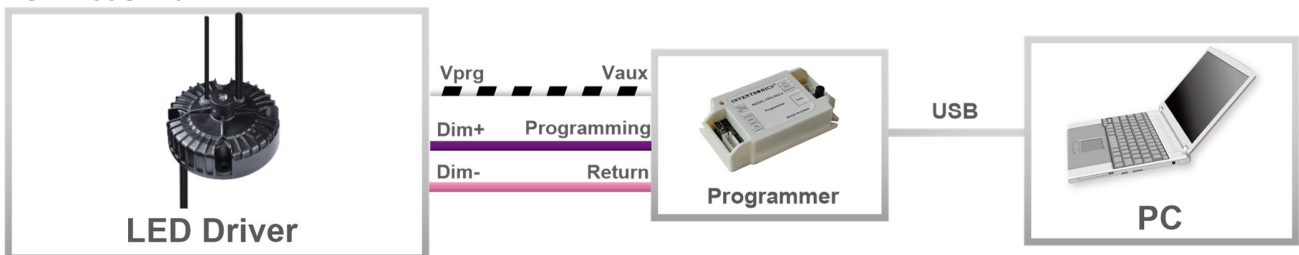

**Note:** The driver does not need to be powered on during the programming process.

- Please refer to [PRG-MUL2 \(Programmer\) datasheet](#) for details.

## Installations

Part Number Suffix: -0001	Installation Type
	

### Caution:

1. Complete visual inspection prior to assembly to insure driver is received in proper condition.
2. Thread length for mounting accessory (ring, etc.) should be 16-22mm. After mounting accessory (ring, etc.) is installed an M4 set screw should be secured in the open location on the driver collar.

- Maximum weight of combined luminaire/driver assembly should not exceed 11Kg.

## Mechanical Outline

### EUR-160S420DG-0001

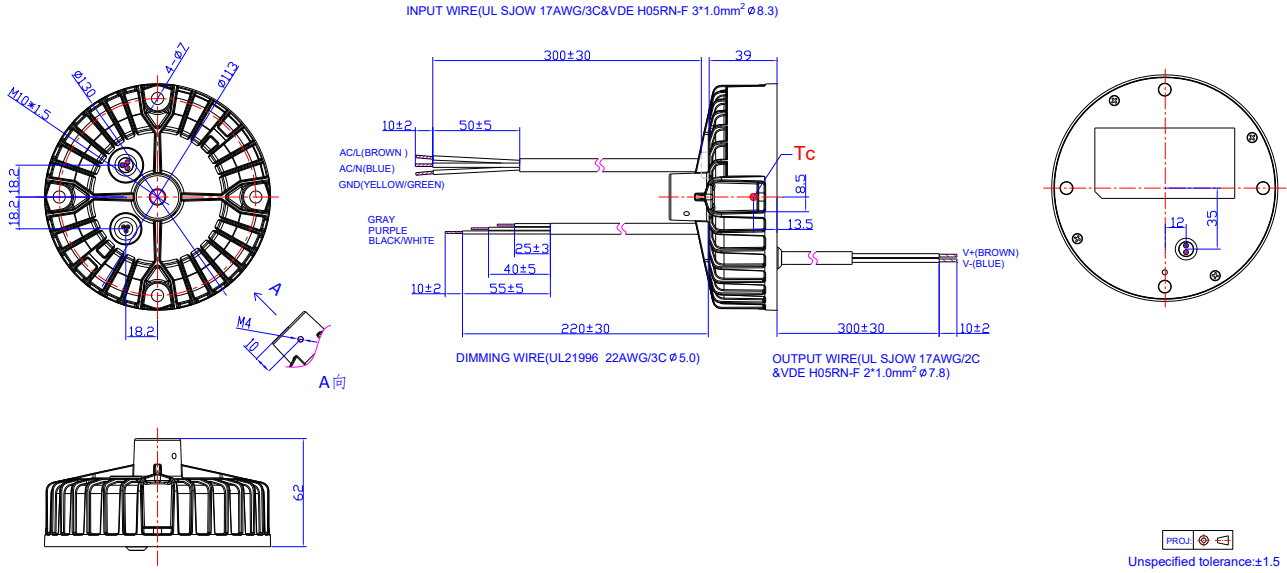

### EUR-160S420SG-0001

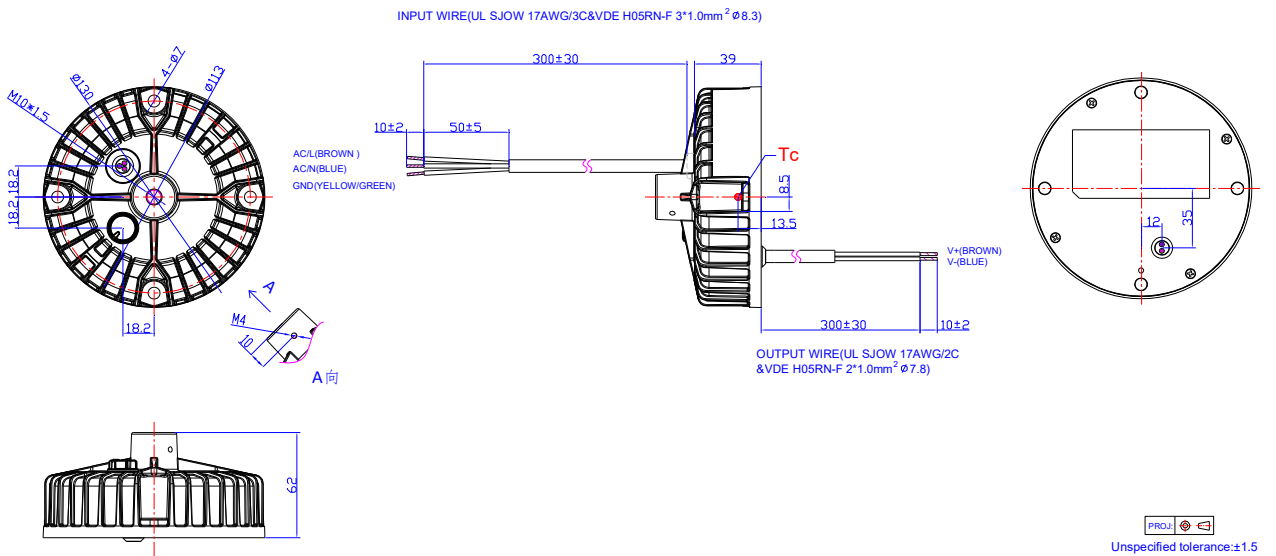

EUR-160S420DT-0001

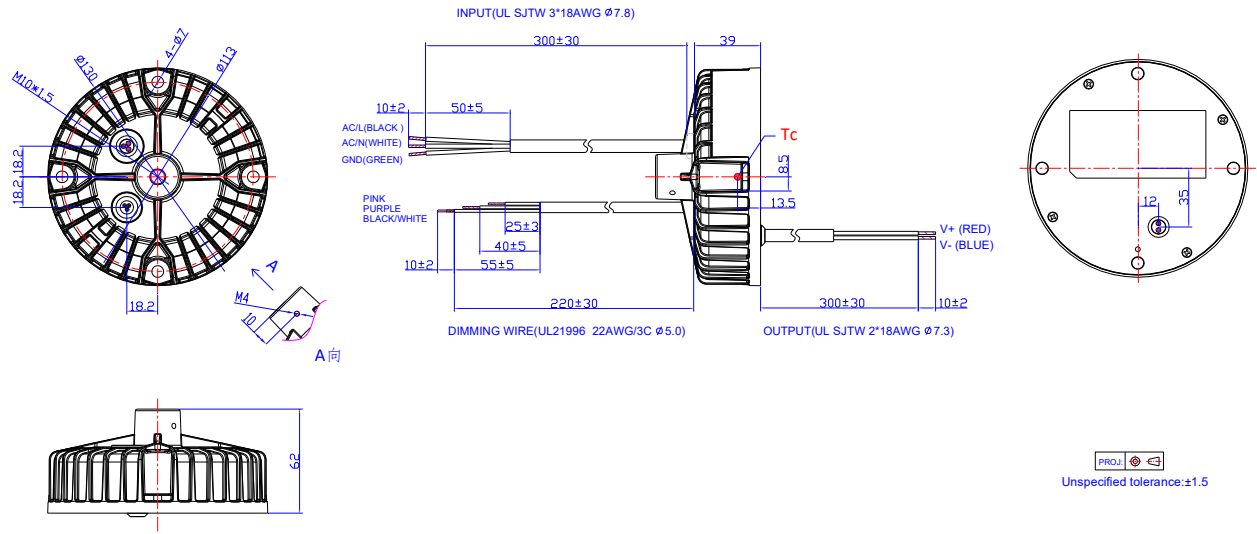

EUR-160S420ST-0001

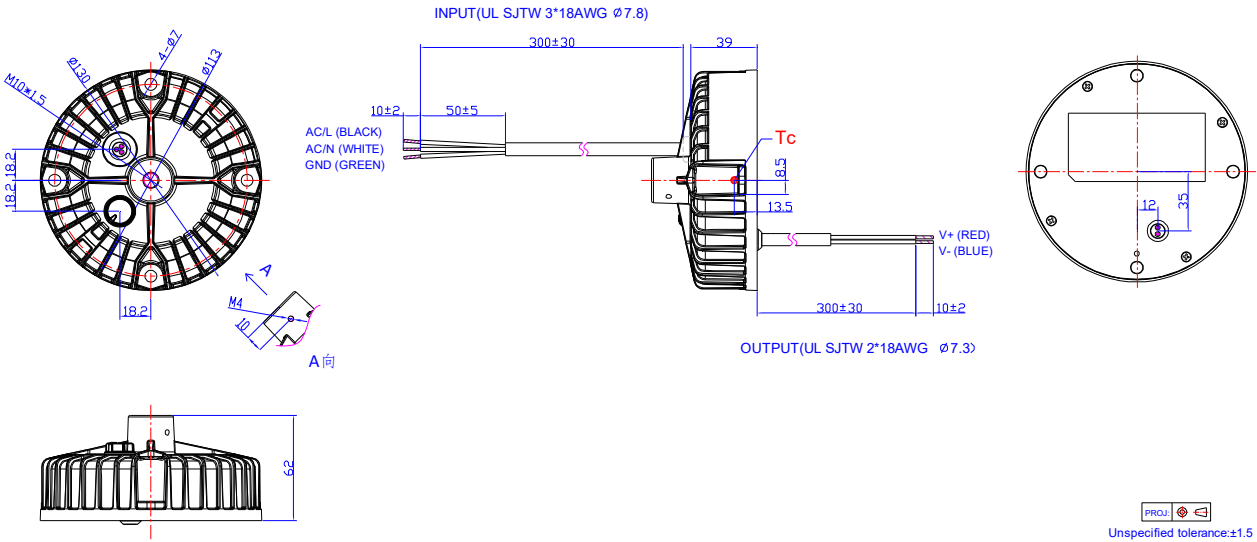

Optional Metal Parts  
BLT-M1000

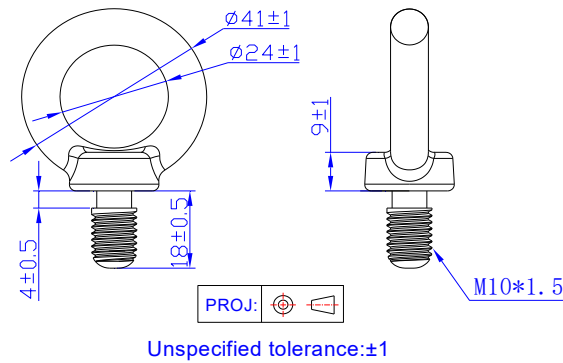

## RoHS Compliance

Our products comply with reference to RoHS Directive (EU) 2015/863 amending 2011/65/EU, calling for the elimination of lead and other hazardous substances from electronic products.

## Revision History

Change Date	Rev.	Description of Change		
		Item	From	To
2020-09-03	A	Datasheet Release	/	/
2022-03-10	B	Programming Connection Diagram	EUR-160S420DT	Updated
		Mechanical Outline	EUR-160S420DT-0001	Updated
2024-03-29	C	ENEC/NOM logo	/	Deleted
		Safety & EMC Compliance	/	Updated
		Programming Connection Diagram	/	Updated
2026-03-27	D	Format	/	Updated
		PSE logo	/	Added
		Safety & EMC Compliance	/	Updated