

## Features

- Full Power at Wide Output Current Range (Constant Power)
- Adjustable Output Current (AOC) with Programmability
- Isolated 1-10V/10V PWM/3-Timer-Modes Dimmable
- Output Lumen Compensation
- End-of-Life Indicator
- Input Surge Protection: DM 6kV, CM 10kV
- All-Around Protection: OVP, SCP, OTP
- IP66/IP67 and UL Dry/Damp/Wet Location
- TYPE HL, for Use in a Class I, Division 2 Hazardous (Classified) Location
- 5 Year Warranty



## Description

The ESM-320SxxxDx series is a 320W, constant-current, programmable and IP66/IP67 rated LED driver that operates from 249-528Vac input with excellent power factor. It is created for many lighting applications including high bay, high mast, aquaculture and sport, etc. The high efficiency of these drivers and compact metal case enables them to run cooler, significantly improving reliability and extending product life. To ensure trouble-free operation, protection is provided against input surge, output over voltage, short circuit, and over temperature.

## Models

Adjustable Output Current Range(mA)	Full-Power Current Range(mA) <sup>(1)</sup>	Default Output Current(mA)	Output Voltage Range(Vdc)	Max. Output Power(W)	Typical Efficiency <sup>(2)</sup>	Typical Power Factor		Model Number <sup>(3)(5)</sup>
						277Vac	480Vac	
70-1050	700-1050	700	153-457	320	95.0%	0.99	0.96	ESM-320S105Dx
105-1500	1050-1500	1400	107-305	320	95.0%	0.99	0.96	ESM-320S150Dx
175-2500	1750-2500	2100	64-183	320	95.0%	0.99	0.96	ESM-320S250Dx
285-5000	2850-5000	4900	32-112	320	94.5%	0.99	0.96	ESM-320S500Dx <sup>(4)</sup>
535-7600	5350-7600	6700	21-60	320	93.5%	0.99	0.96	ESM-320S760Dx <sup>(4)</sup>

- Notes:** (1) Output current range with constant power at 320W  
 (2) Measured at 100% load and 480Vac input (see below "General Specifications" for details).  
 (3) Certified input voltage range: 277-480Vac.  
 (4) SELV output.  
 (5) x = G are UL Recognized and ENEC, etc. models; x = T are UL Class P models.

## I-V Operation Area

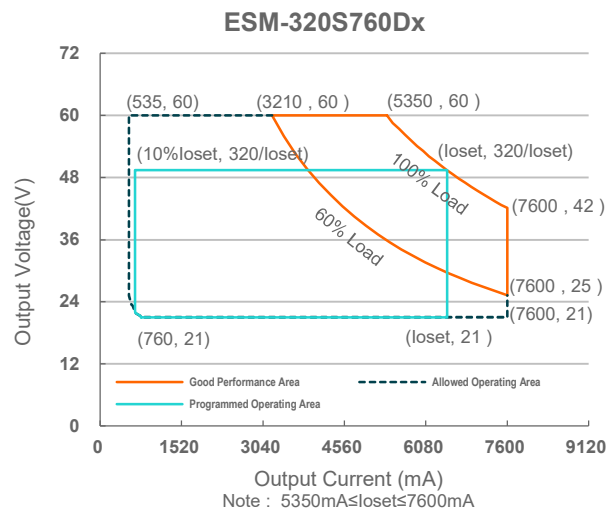
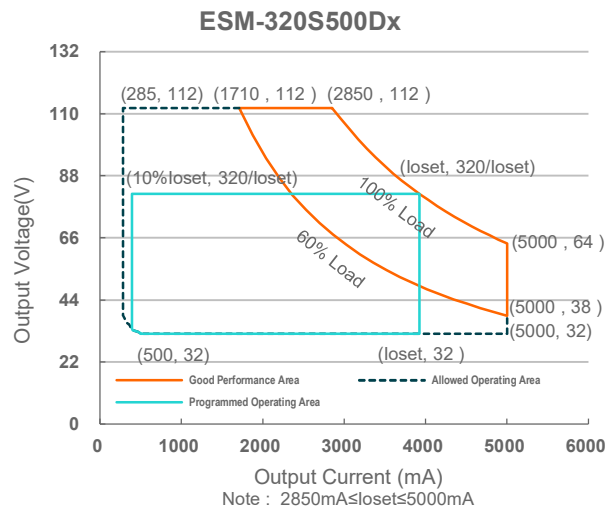
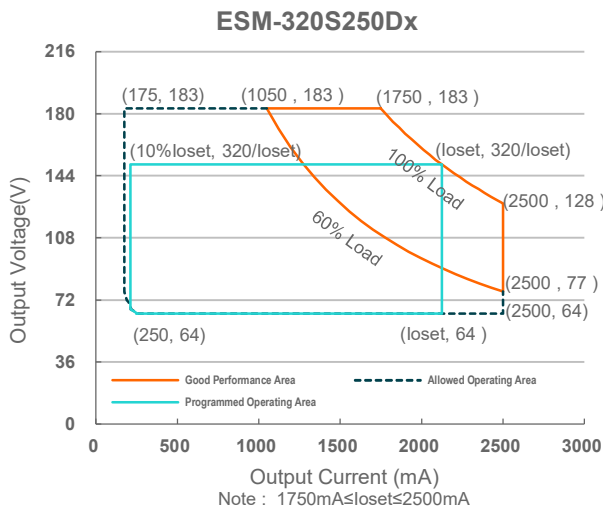
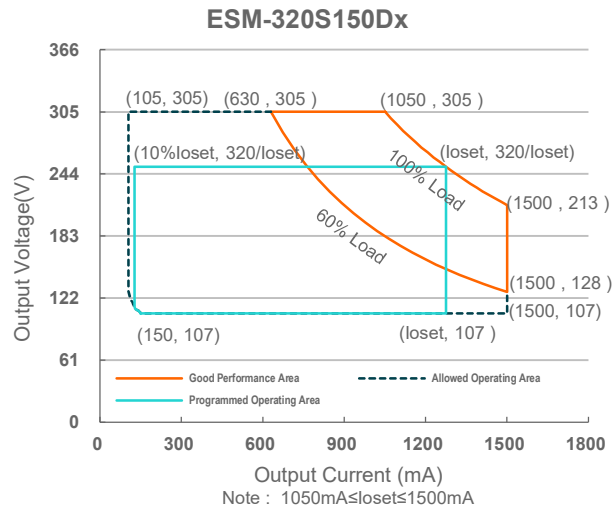
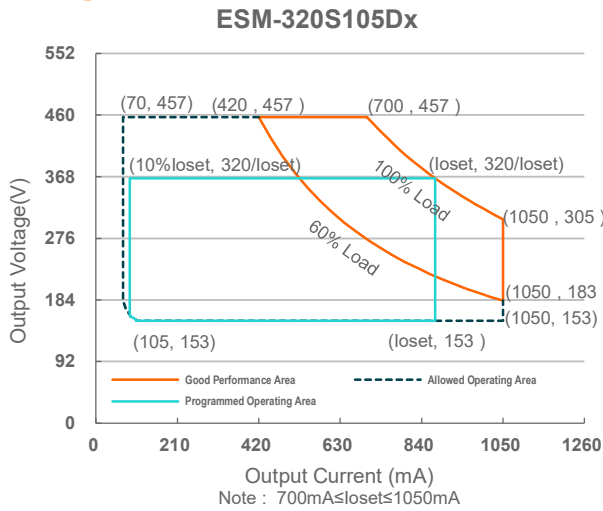

## Input Specifications

Parameter	Min.	Typ.	Max.	Notes
Input AC Voltage	249 Vac	-	528 Vac	
Input DC Voltage	352 Vdc		500 Vdc	
Input Frequency	47 Hz	-	63 Hz	
Leakage Current	-	-	0.75 MIU	UL 8750; 480Vac/60Hz
	-	-	0.70 mA	IEC 60598-1; 480Vac/60Hz
Input AC Current	-	-	1.38 A	Measured at 100% load and 277 Vac input.
	-	-	0.81 A	Measured at 100% load and 480 Vac input.
Inrush Current(I <sup>2</sup> t)	-	-	1.409 A <sup>2</sup> s	At 480Vac input, 25°C cold start, duration=4.56 ms, 10%I <sub>pk</sub> -10%I <sub>pk</sub> .
PF	0.9	-	-	At 277-480Vac, 50-60Hz, 60%-100% Load (192-320W)
THD	-	-	20%	

## Output Specifications

Parameter	Min.	Typ.	Max.	Notes
Output Current Tolerance	-5%loset	-	5%loset	At 100% load condition
Output Current Setting(loset) Range				
ESM-320S105Dx	70 mA	-	1050 mA	
ESM-320S150Dx	105 mA	-	1500 mA	
ESM-320S250Dx	175 mA	-	2500 mA	
ESM-320S500Dx	285 mA	-	5000 mA	
ESM-320S760Dx	535 mA	-	7600 mA	
Output Current Setting Range with Constant Power				
ESM-320S105Dx	700 mA	-	1050 mA	
ESM-320S150Dx	1050 mA	-	1500 mA	
ESM-320S250Dx	1750 mA	-	2500 mA	
ESM-320S500Dx	2850 mA	-	5000 mA	
ESM-320S760Dx	5350 mA	-	7600 mA	
Total Output Current Ripple (pk-pk)	-	5%I <sub>omax</sub>	10%I <sub>omax</sub>	At 100% load condition. 20 MHz BW
Output Current Ripple at < 200 Hz (pk-pk)	-	2%I <sub>omax</sub>	-	At 100% load condition. Only this component of ripple is associated with visible flicker.
Startup Overshoot Current	-	-	10%I <sub>omax</sub>	At 100% load condition
No Load Output Voltage				
ESM-320S105Dx	-	-	500 V	
ESM-320S150Dx	-	-	340 V	
ESM-320S250Dx	-	-	210 V	
ESM-320S500Dx	-	-	120 V	
ESM-320S760Dx	-	-	70 V	
Line Regulation	-	-	±0.5%	Measured at 100% load
Load Regulation	-	-	±1.5%	

## Output Specifications (Continued)

Parameter	Min.	Typ.	Max.	Notes
Turn-on Delay Time	-	-	0.5 s	Measured at 277-480Vac input, 60%-100%load
Temperature Coefficient of loset	-	0.03%/°C	-	Case temperature = 0°C~Tc max

## General Specifications

Parameter	Min.	Typ.	Max.	Notes
Efficiency at 277 Vac input: ESM-320S105Dx				Measured at 100% load and steady-state temperature in 25°C ambient; (Efficiency will be about 2.0% lower if measured immediately after startup.)
Io= 700 mA	92.0%	94.0%	-	
Io=1050 mA	91.0%	93.0%	-	
ESM-320S150Dx				
Io=1050 mA	92.0%	94.0%	-	
Io=1500 mA	92.0%	94.0%	-	
ESM-320S250Dx				
Io=1750 mA	92.0%	94.0%	-	
Io=2500 mA	91.0%	93.0%	-	
ESM-320S500Dx				
Io=2850 mA	91.5%	93.5%	-	
Io=5000 mA	90.0%	92.0%	-	
ESM-320S760Dx				
Io=5350 mA	90.5%	92.5%	-	
Io=7600 mA	90.0%	92.0%	-	
Efficiency at 400 Vac input: ESM-320S105Dx				Measured at 100% load and steady-state temperature in 25°C ambient; (Efficiency will be about 2.0% lower if measured immediately after startup.)
Io= 700 mA	93.0%	95.0%	-	
Io=1050 mA	92.0%	94.0%	-	
ESM-320S150Dx				
Io=1050 mA	92.5%	94.5%	-	
Io=1500 mA	92.5%	94.5%	-	
ESM-320S250Dx				
Io=1750 mA	93.0%	95.0%	-	
Io=2500 mA	92.0%	94.0%	-	
ESM-320S500Dx				
Io=2850 mA	92.5%	94.5%	-	
Io=5000 mA	90.5%	92.5%	-	
ESM-320S760Dx				
Io=5350 mA	91.5%	93.5%	-	
Io=7600 mA	90.5%	92.5%	-	
Efficiency at 480 Vac input: ESM-320S105Dx				Measured at 100% load and steady-state temperature in 25°C ambient; (Efficiency will be about 2.0% lower if measured immediately after startup.)
Io= 700 mA	93.0%	95.0%	-	
Io=1050 mA	92.0%	94.0%	-	
ESM-320S150Dx				
Io=1050 mA	93.0%	95.0%	-	
Io=1500 mA	92.5%	94.5%	-	
ESM-320S250Dx				
Io=1750 mA	93.0%	95.0%	-	
Io=2500 mA	92.0%	94.0%	-	
ESM-320S500Dx				
Io=2850 mA	92.5%	94.5%	-	
Io=5000 mA	90.5%	92.5%	-	
ESM-320S760Dx				
Io=5350 mA	91.5%	93.5%	-	
Io=7600 mA	91.5%	93.5%	-	

## General Specifications (Continued)

Parameter	Min.	Typ.	Max.	Notes
MTBF	-	296,000 Hours	-	Measured at 480Vac input, 80%load and 25°C ambient temperature (MIL-HDBK-217F)
Lifetime	-	104,000 Hours	-	Measured at 480Vac input, 80%load and 70°C case temperature; See lifetime vs. Tc curve for the details
Operating Case Temperature for Safety Tc_s	-40°C	-	+90°C	
Operating Case Temperature for Warranty Tc_w	-40°C	-	+80°C	Case temperature for 5 years warranty Humidity: 10% RH to 95% RH
Storage Temperature	-40°C	-	+85°C	Humidity: 5%RH to 95%RH
Dimensions: Inches (L × W × H) Millimeters (L × W × H)	8.82 × 3.15 × 1.75 224 × 80 × 44.5			With mounting ear 9.57 × 3.15 × 1.75 243 × 80 × 44.5
Net Weight	-	1530 g	-	

## Dimming Specifications

Parameter	Min.	Typ.	Max.	Notes	
Absolute Maximum Voltage on the Vdim (+) Pin	-20 V	-	20 V		
Source Current on Vdim (+)Pin	200 µA	300 µA	450 µA	Vdim(+) = 0 V	
Dimming Output Range	ESM-320S105Dx ESM-320S150Dx ESM-320S250Dx ESM-320S500Dx ESM-320S760Dx	10%loset	-	loset	700 mA ≤ loset ≤ 1050 mA 1050 mA ≤ loset ≤ 1500 mA 1750 mA ≤ loset ≤ 2500 mA 2850 mA ≤ loset ≤ 5000 mA 5350 mA ≤ loset ≤ 7600 mA
	ESM-320S105Dx ESM-320S150Dx ESM-320S250Dx ESM-320S500Dx ESM-320S760Dx	70 mA 105 mA 175 mA 285 mA 535 mA	-	loset	70 mA ≤ loset < 700 mA 105 mA ≤ loset < 1050 mA 175 mA ≤ loset < 1750 mA 285 mA ≤ loset < 2850 mA 535 mA ≤ loset < 5350 mA
Recommended Dimming Range for 1-10V	1 V	-	9 V	Default 1-10V dimming mode with positive logic.	
PWM_in High Level	-	10 V	-		
PWM_in Low Level	-	0 V	-		
PWM_in Frequency Range	200 Hz	-	2 KHz		
PWM_in Duty Cycle	0%	-	100%		

## Safety & EMC Compliance

Safety Category	Standard
UL/CUL	UL 8750,CAN/CSA-C22.2 No. 250.13
ENEC & CE	EN 61347-1, EN 61347-2-13
CB	IEC 61347-1, IEC 61347-2-13
EAC	TP TC 004, TP TC 020
Performance	Standard
ENEC	EN IEC 62384
EMI Standards	Notes
EN IEC 55015 <sup>(1)</sup>	Conducted emission Test & Radiated emission Test
EN IEC 61000-3-2	Harmonic current emissions
EN 61000-3-3	Voltage fluctuations & flicker
FCC Part 15 <sup>(1)</sup>	ANSI C63.4 Class B
	This device complies with Part 15 of the FCC Rules. Operation is subject to the following two conditions: [1] this device may not cause harmful interference, and [2] this device must accept any interference received, including interference that may cause undesired operation.
EMS Standards	Notes
EN 61000-4-2	Electrostatic Discharge (ESD): 8 kV air discharge, 4 kV contact discharge
EN 61000-4-3	Radio-Frequency Electromagnetic Field Susceptibility Test-RS
EN 61000-4-4	Electrical Fast Transient / Burst-EFT
EN 61000-4-5	Surge Immunity Test: AC Power Line: Differential Mode 6 kV, Common Mode 10 kV
EN 61000-4-6	Conducted Radio Frequency Disturbances Test-CS
EN 61000-4-8	Power Frequency Magnetic Field Test
EN 61000-4-11	Voltage Dips
EN 61547	Electromagnetic Immunity Requirements Applies To Lighting Equipment

**Note:** (1) This LED driver meets the EMI specifications above, but EMI performance of a luminaire that contains it depends also on the other devices connected to the driver and on the fixture itself.

## Lifetime vs. Case Temperature

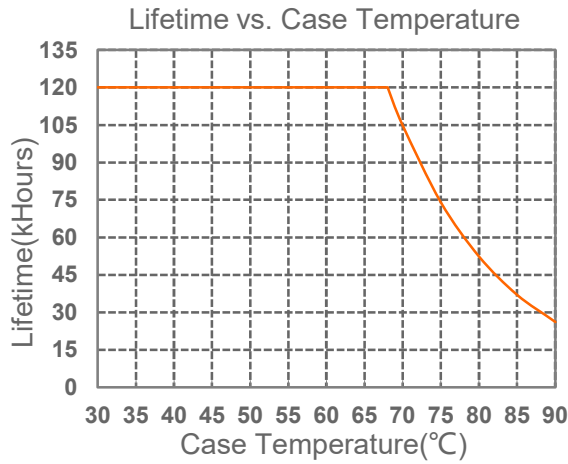

## Inrush Current Waveform

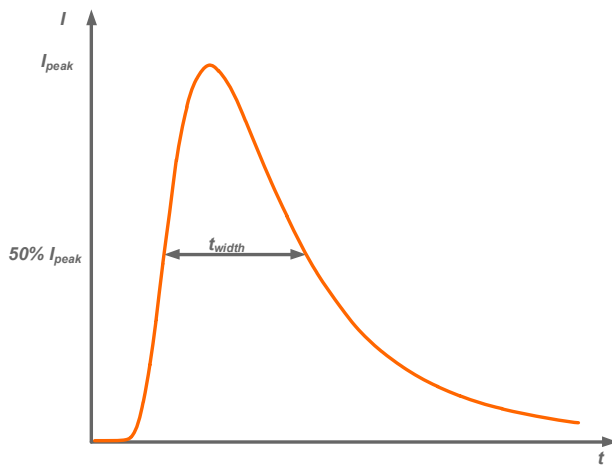

Input AC Voltage	$I_{peak}$	$t_{width}$ (@ 50% $I_{peak}$ )
480Vac	20.3A	1.28ms

## Efficiency vs. Load

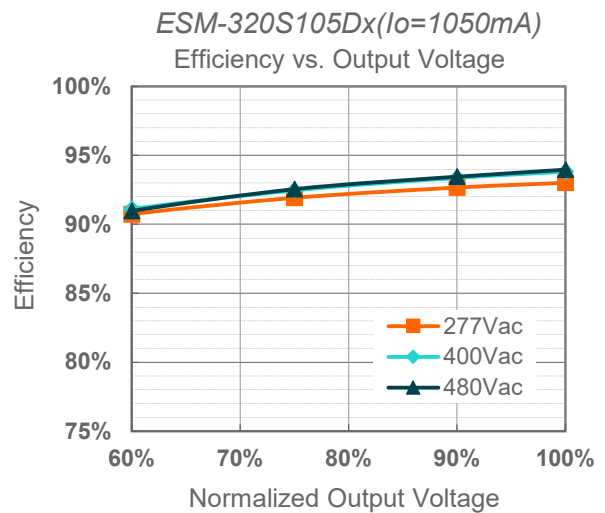
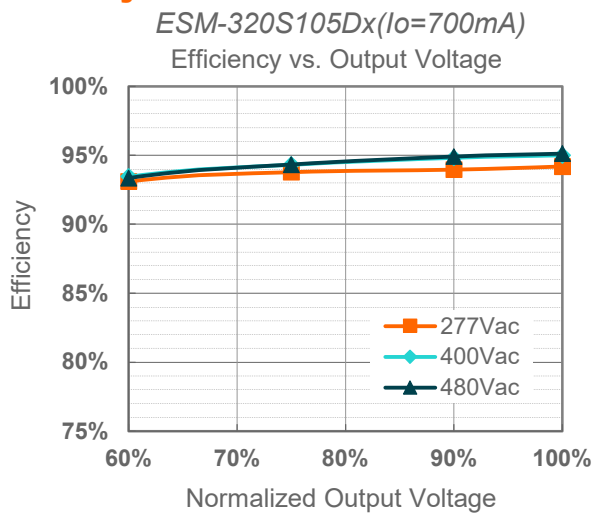

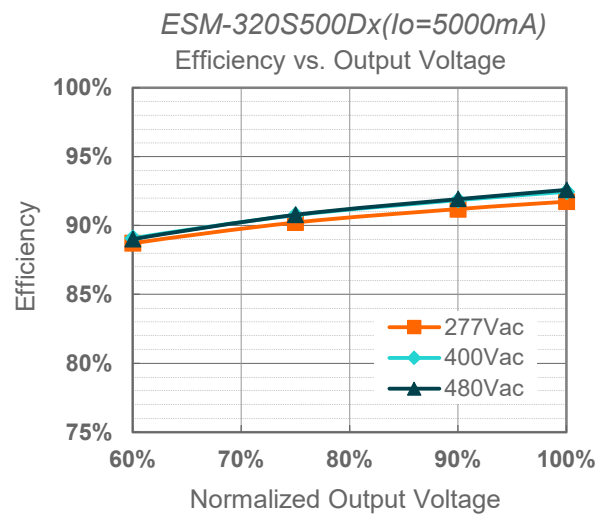
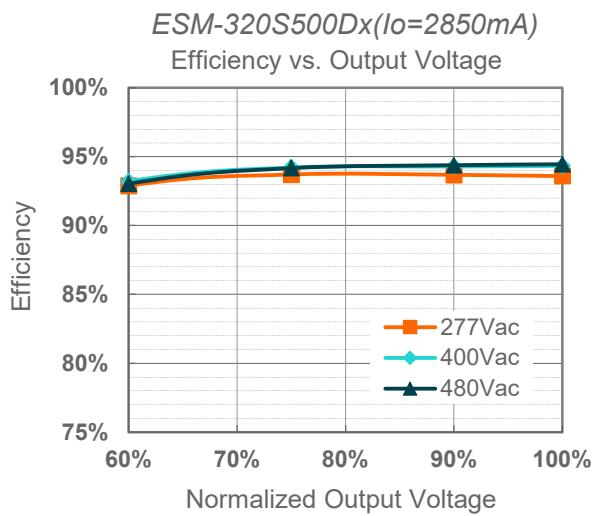
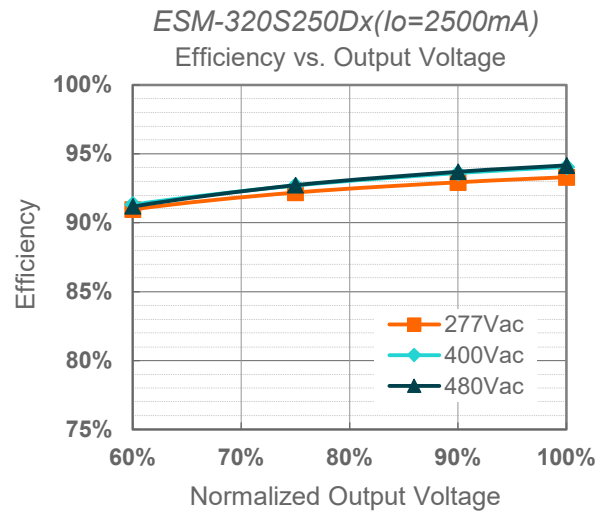
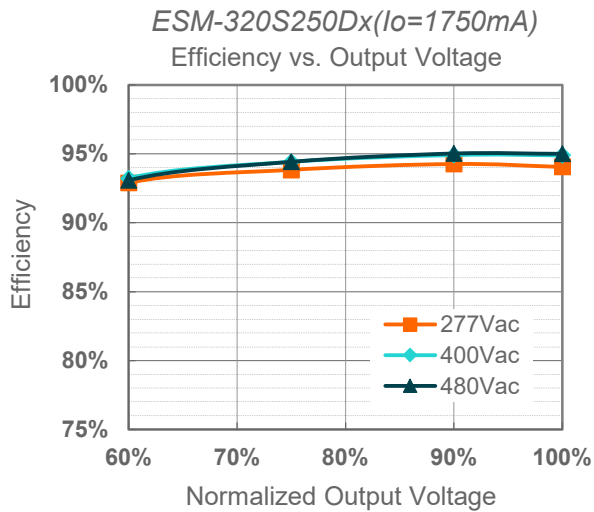
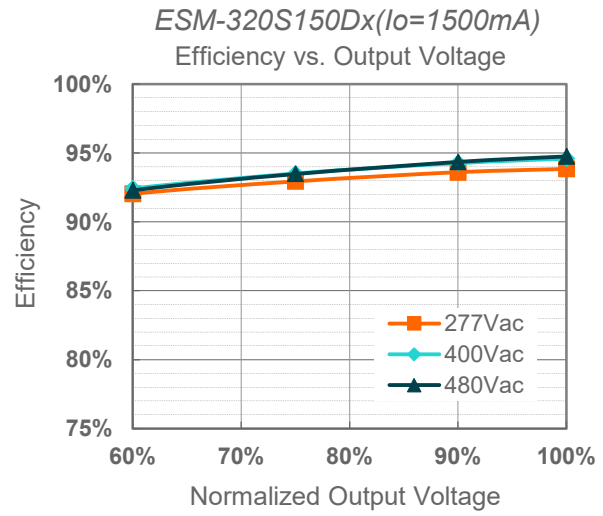
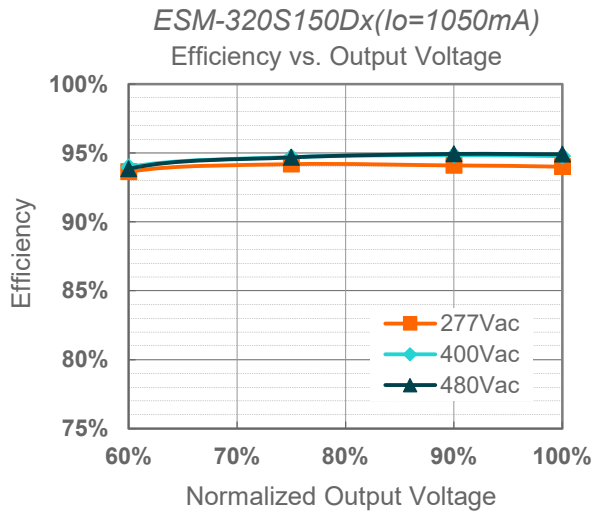

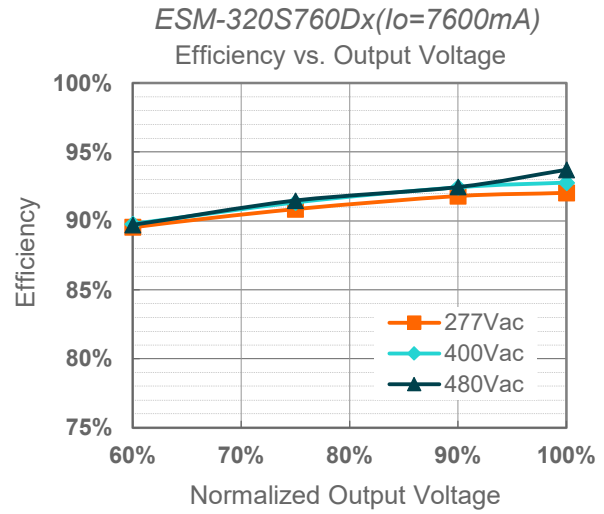
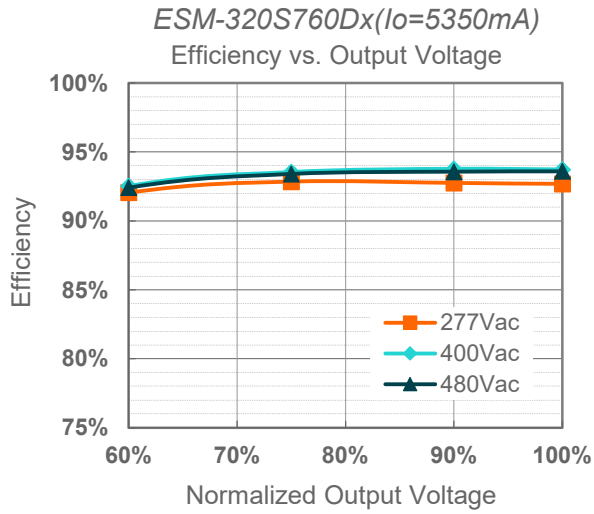

## Power Factor

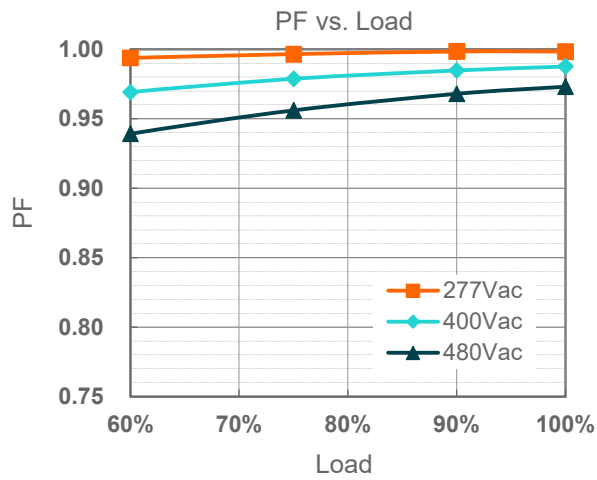

## Total Harmonic Distortion

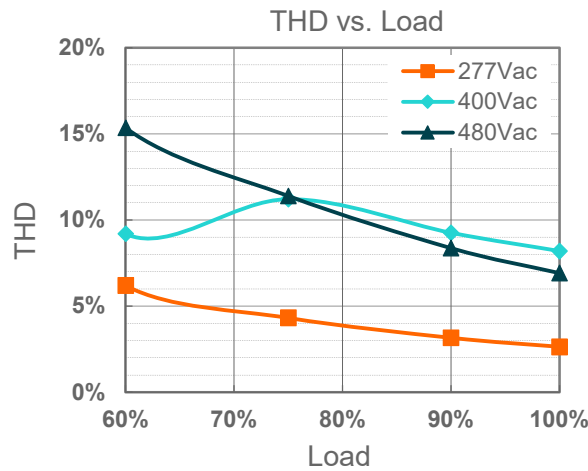

## Protection Functions

Parameter	Notes
Over Voltage Protection	Limits output voltage at no load and in case the normal voltage limit fails.
Short Circuit Protection	Auto Recovery. No damage will occur when any output is short circuited. The output shall return to normal when the fault condition is removed.
Over Temperature Protection	Decreases output current, returning to normal after over temperature is removed.

## Dimming

### ● 1-10V Dimming

The recommended implementation of the dimming control is provided below.

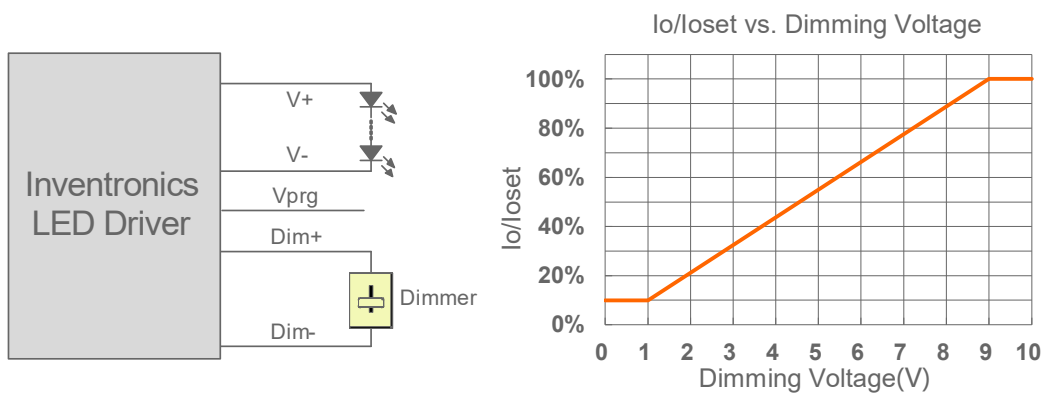

**Implementation 1: Positive logic**

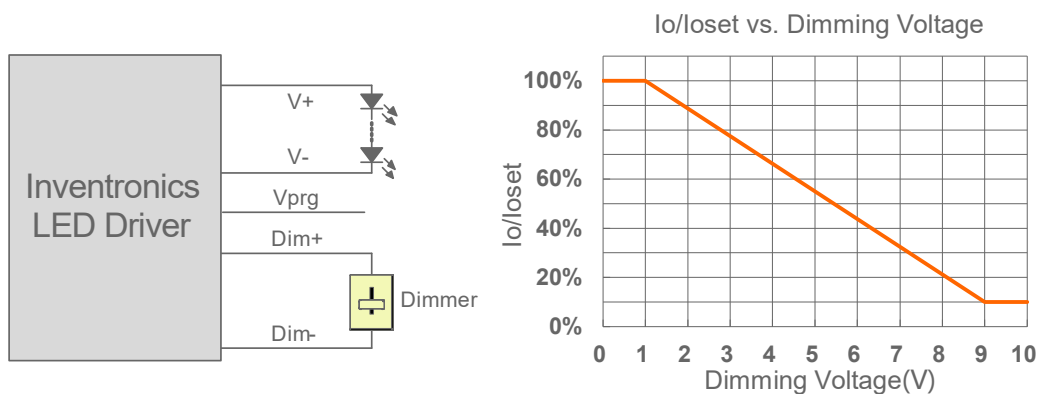

**Implementation 2: Negative logic**

### Notes:

1. Do NOT connect Dim- to the output V- or V+, otherwise the driver will not work properly.
2. The dimmer can also be replaced by an active 1-10V voltage source signal or passive components like zener.
3. When 1-10V negative logic dimming mode and Dim+ is open, the driver will output minimum current.

## ● 10V PWM Dimming

The recommended implementation of the dimming control is provided below.

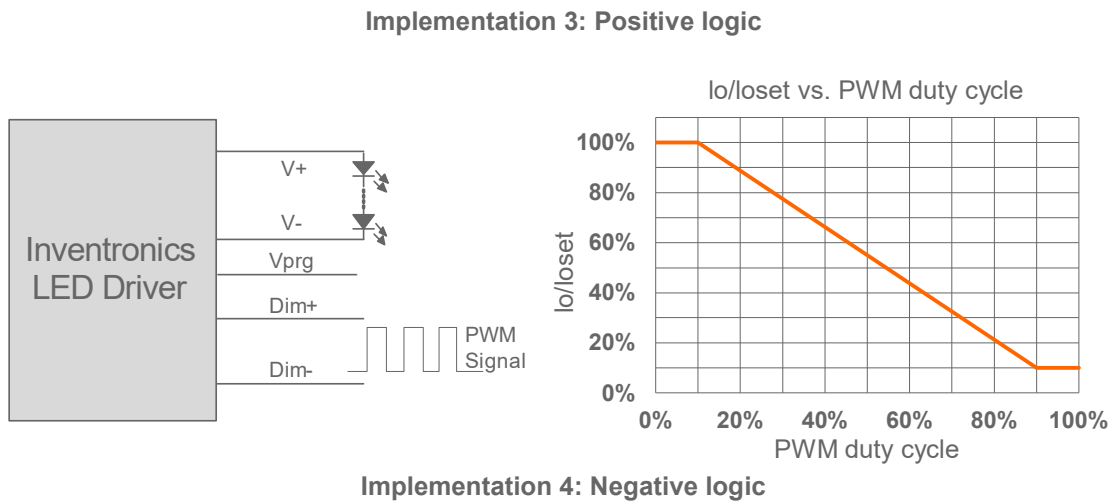
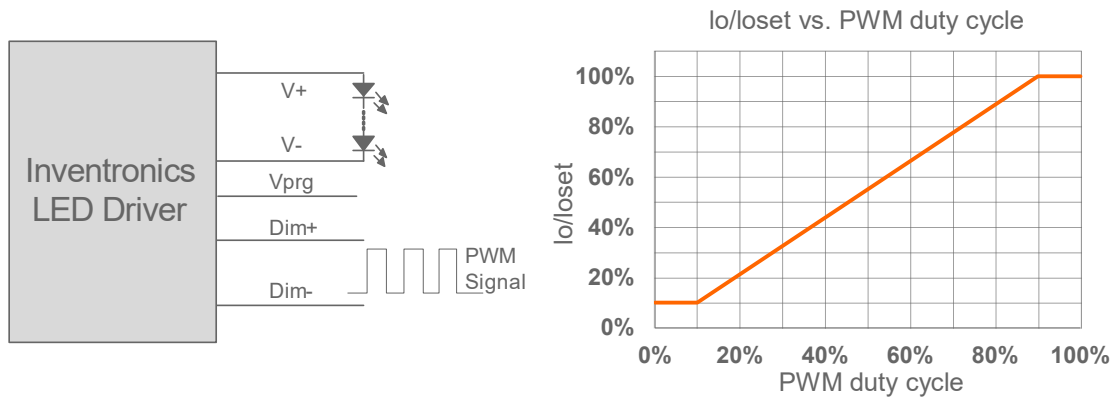

### Notes:

1. Do NOT connect Dim- to the output V- or V+, otherwise the driver will not work properly.
2. When 10V PWM negative logic dimming mode and Dim+ is open, the driver will output minimum current.

## ● Time Dimming

Time dimming control includes 3 kinds of modes, they are Self Adapting-Midnight, Self Adapting-Percentage and Traditional Timer.

- **Self Adapting-Midnight:** Automatically adjusts the dimming curve based on the on-time of past two days (if difference <15 minutes), assuming that the center point of the dimming curve is midnight local time.
- **Self Adapting-Percentage:** Automatically adjusts the on-time of each step by a constant percentage = (actual on-time for the past 2 days if difference <15 min) / (programmed on-time from the dimming curve).
- **Traditional Timer:** Follows the programmed timing curve after power on with no changes.

## ● Output Lumen Compensation

Output Lumen Compensation (OLC) may be used to maintain constant light output over the life of the LEDs by driving them at a reduced current when new, then gradually increasing the drive current over time to counteract LED lumen degradation.

## ● End Of Life

End-of-Life (EOL) is providing a visual notification to a user that the LED module has reached the end of manufacturer-specified life and that the replacement is recommended. Once active, an indication is given at each power-up of the driver, which the driver indicates this through a lower light output during the first 1 minute before normal operation is continued.

## Programming Connection Diagram

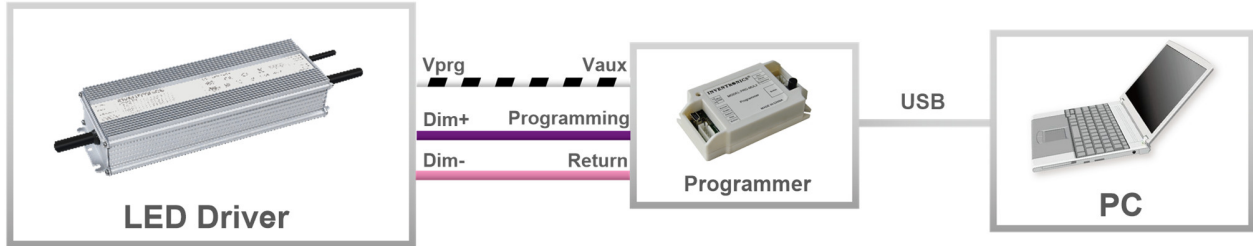

**Note:** The driver does not need to be powered on during the programming process.

● Please refer to [PRG-MUL2 \(Programmer\) datasheet](#) for details.

## Mechanical Outline

ESM-320S105DG/ESM-320S150DG

INPUT(UL SOOW 17AWG/3C & VDE H07RN-F 3\*1.0mm<sup>2</sup> Ø9.8)

DIMMING(UL21996 22AWG/3C Ø5.0)

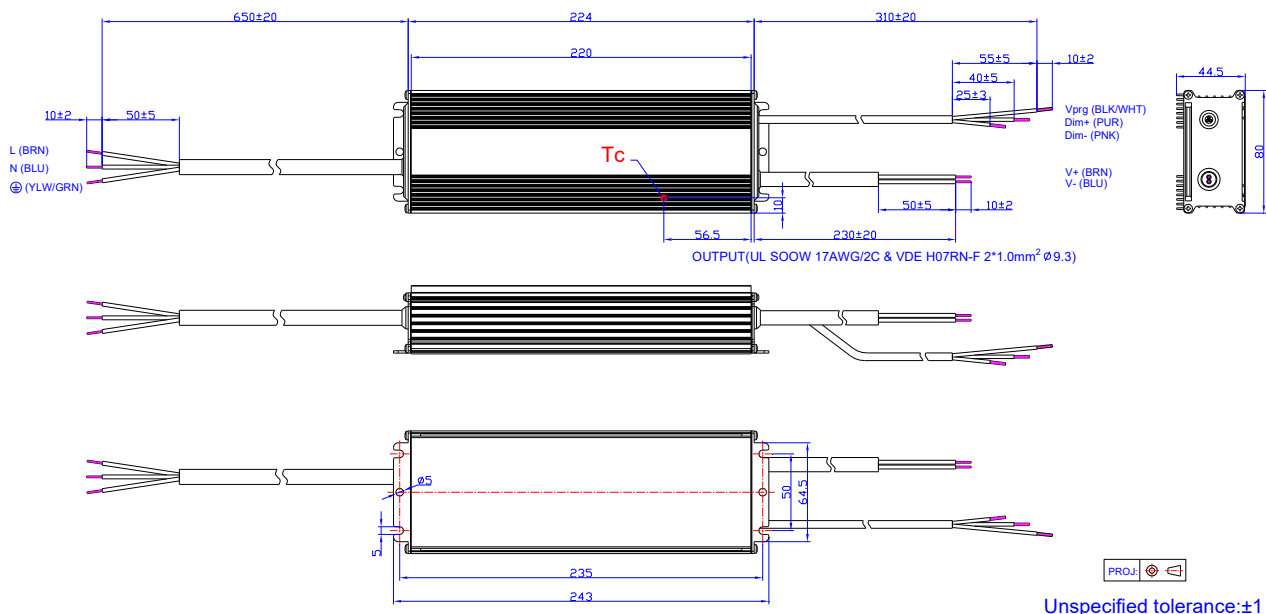

## ESM-320S250DG/ESM-320S500DG/ESM-320S760DG

INPUT(UL SOOW 17AWG/3C & VDE H07RN-F 3\*1.0mm<sup>2</sup> Ø9.8)

DIMMING(UL21996 22AWG/3C Ø5.0)

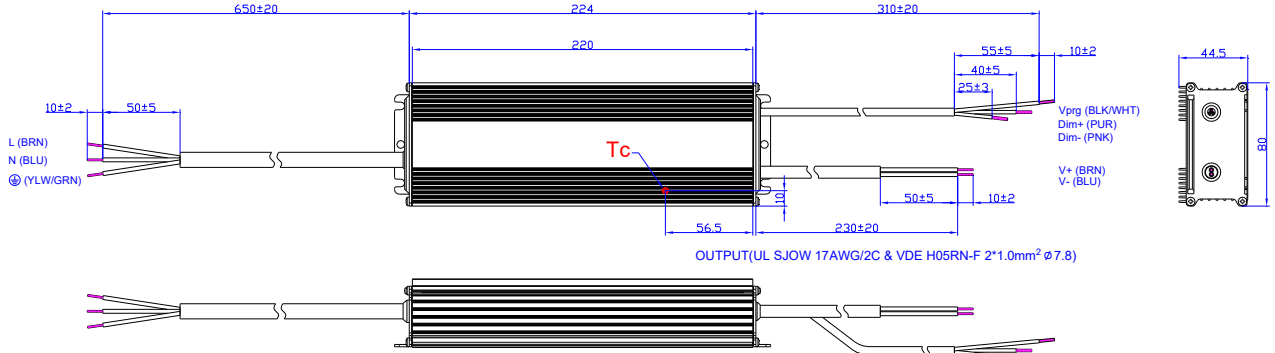

Unspecified tolerance:±1

## ESM-320S105DT/ESM-320S150DT

INPUT(UL STW 18AWG/3C Ø9.5)

DIMMING(UL21996 22AWG/3C Ø5.0)

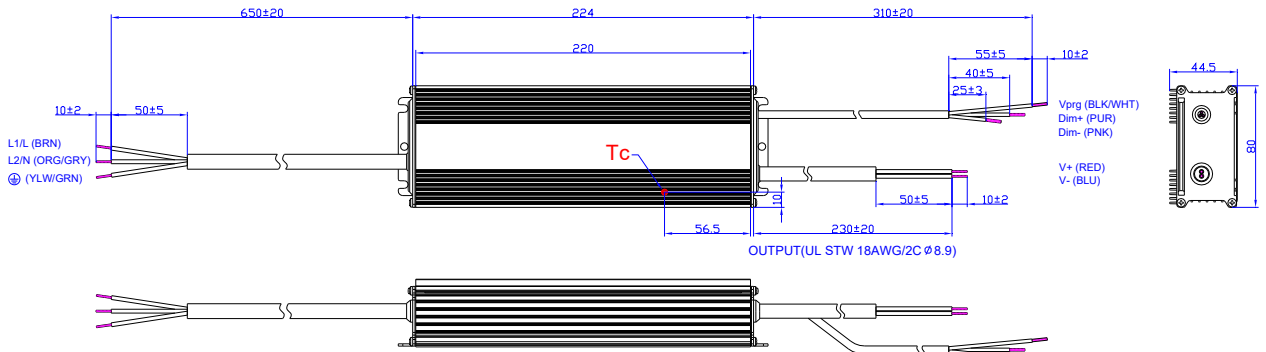

Unspecified tolerance:±1

ESM-320S250DT/ESM-320S500DT/ESM-320S760DT

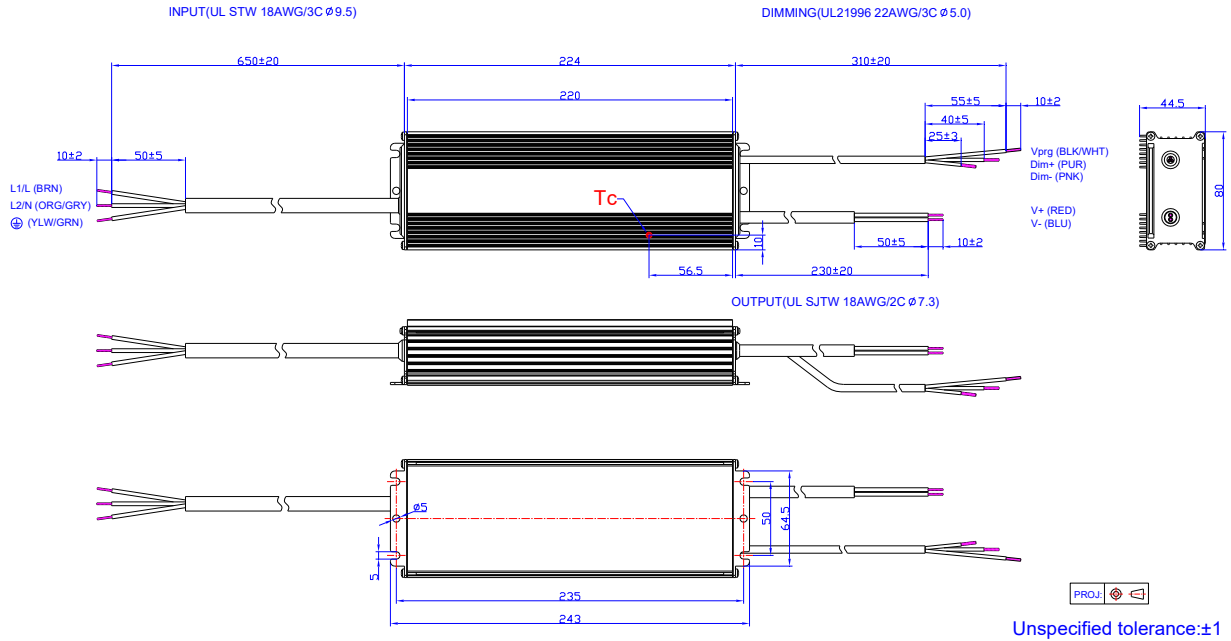

## RoHS Compliance

Our products comply with reference to RoHS Directive (EU) 2015/863 amending 2011/65/EU, calling for the elimination of lead and other hazardous substances from electronic products.

## Revision History

Change Date	Rev.	Description of Change		
		Item	From	To
2020-08-17	A	Datasheet Release	/	/
2022-01-08	B	UKCA / EAC logo	/	Added
		Safety &EMC Compliance	/	Added
		Programming Connection Diagram	/	Updated
		Mechanical Outline	ESM-320SxxxDT	Updated
2023-07-05	C	Product Photograph	/	Updated
		Safety &EMC Compliance	/	Updated
		Dimming	/	Updated
		Programming Connection Diagram	/	Updated
		Mechanical Outline	/	Updated
2026-03-10	D	Format	/	Updated
		Product Photograph	/	Updated
		UKCA logo	/	Deleted
		Safety &EMC Compliance	/	Updated
		Inrush Current Waveform	/	Updated