

## Features

- Full Power at Wide Output Current Range (Constant Power)
- Adjustable Output Current (AOC) with Programmability
- Isolated 1-10V/10V PWM/3-Timer-Modes Dimmable
- Output Lumen Compensation
- End-of-Life Indicator
- Input Surge Protection: DM 6kV, CM 10kV
- All-Around Protection: OVP, SCP, OTP
- IP66/IP67 and UL Dry/Damp/Wet Location
- TYPE HL, for use in a Class I, Division 2 Hazardous (Classified) Location
- 5 Years Warranty



## Description

The ESM-240SxxxDx series is a 240W, constant-current, programmable and IP66/IP67 rated LED driver that operates from 249-528Vac input with excellent power factor. It is created for many lighting applications including high bay, high mast and roadway, etc. The high efficiency of these drivers and compact metal case enables them to run cooler, significantly improving reliability and extending product life. To ensure trouble-free operation, protection is provided against input surge, output over voltage, short circuit, and over temperature.

## Models

Adjustable Output Current Range(mA)	Full-Power Current Range(mA) <sup>(1)</sup>	Default Output Current(mA)	Output Voltage Range(Vdc)	Max. Output Power(W)	Typical Efficiency <sup>(2)</sup>	Typical Power Factor		Model Number <sup>(3)(5)</sup>
						277Vac	480Vac	
70-1050	700-1050	700	115-343	240	94.5%	0.99	0.95	ESM-240S105Dx
105-1500	1050-1500	1050	80-229	240	94.0%	0.99	0.95	ESM-240S150Dx
215-3500	2150-3500	2150	35-111	240	94.0%	0.99	0.95	ESM-240S350Dx <sup>(4)</sup>
420-6700	4200-6700	4900	18-57	240	93.0%	0.99	0.95	ESM-240S670Dx <sup>(4)</sup>

- Notes:** (1) Output current range with constant power at 240W  
 (2) Measured at 100%load and 480Vac input (see below "General Specifications" for details).  
 (3) Certified input voltage range: 277-480Vac.  
 (4) SELV output.  
 (5) x = G are UL Recognized and ENEC, etc. models; x = T are UL Class P models.

## I-V Operation Area

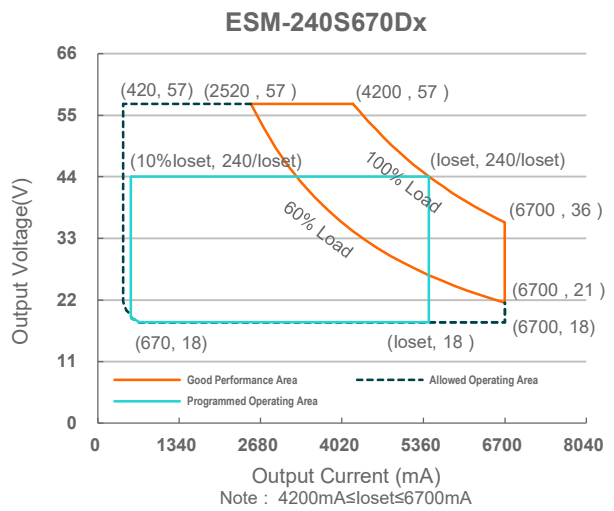
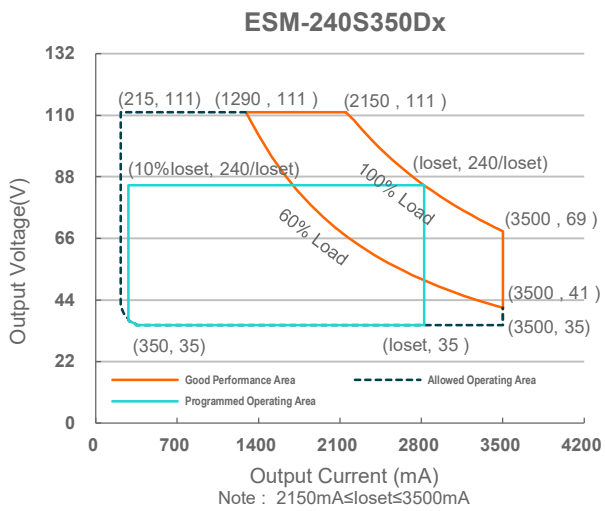
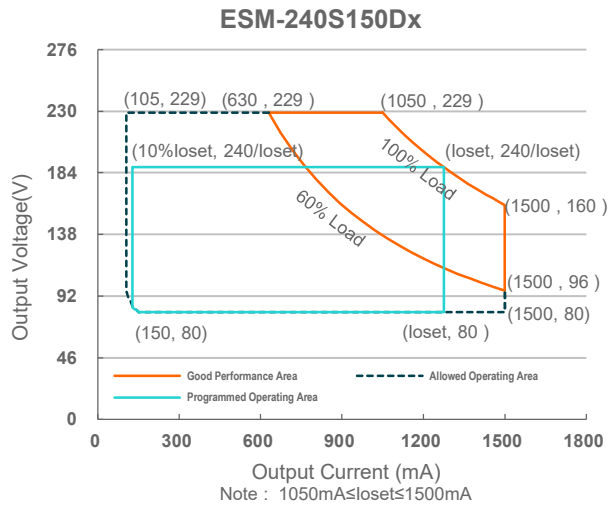
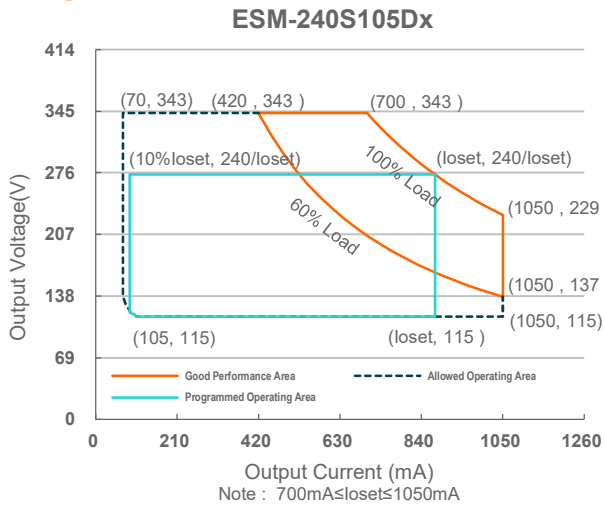

## Input Specifications

Parameter	Min.	Typ.	Max.	Notes
Input AC Voltage	249 Vac	-	528 Vac	
Input DC Voltage	352 Vdc	-	500 Vdc	
Input Frequency	47 Hz	-	63 Hz	
Leakage Current	-	-	0.75 MIU	UL 8750; 480Vac/ 60Hz
	-	-	0.70 mA	IEC 60598-1; 480Vac/ 60Hz
Input AC Current	-	-	1.1 A	Measured at 100% load and 277 Vac input.
	-	-	0.66 A	Measured at 100% load and 480 Vac input.
Inrush Current(I <sup>2</sup> t)	-	-	2.095 A <sup>2</sup> s	At 480Vac input, 25°C cold start, duration=520 μs, 10%Ipk-10%Ipk.

## Input Specifications (Continued)

Parameter	Min.	Typ.	Max.	Notes
PF	0.9	-	-	At 277-480Vac, 50-60Hz, 60%-100%load (144-240W)
THD	-	-	20%	

## Output Specifications

Parameter	Min.	Typ.	Max.	Notes
Output Current Tolerance	-5%loset	-	5%loset	At 100%load condition
Output Current Setting(loset) Range				
ESM-240S105Dx	70 mA	-	1050 mA	
ESM-240S150Dx	105 mA	-	1500 mA	
ESM-240S350Dx	215 mA	-	3500 mA	
ESM-240S670Dx	420 mA	-	6700 mA	
Output Current Setting Range with Constant Power				
ESM-240S105Dx	700 mA	-	1050 mA	
ESM-240S150Dx	1050 mA	-	1500 mA	
ESM-240S350Dx	2150 mA	-	3500 mA	
ESM-240S670Dx	4200 mA	-	6700 mA	
Total Output Current Ripple (pk-pk)	-	5%lomax	10%lomax	At 100% load condition. 20 MHz BW
Output Current Ripple at < 200 Hz (pk-pk)	-	2%lomax	-	At 100% load condition. Only this component of ripple is associated with visible flicker.
Startup Overshoot Current	-	-	10%lomax	At 100% load condition
No Load Output Voltage				
ESM-240S105Dx	-	-	380 V	
ESM-240S150Dx	-	-	260 V	
ESM-240S350Dx	-	-	120 V	
ESM-240S670Dx	-	-	70 V	
Line Regulation	-	-	±0.5%	Measured at 100% load
Load Regulation	-	-	±1.5%	
Turn-on Delay Time	-	-	0.5 s	Measured at 277-480Vac input, 60%-100%load
Temperature Coefficient of loset	-	0.03%/°C	-	Case temperature = 0°C ~Tc max

## General Specifications

Parameter	Min.	Typ.	Max.	Notes
Efficiency at 277 Vac input: ESM-240S105Dx				
I <sub>o</sub> = 700 mA	91.5%	93.5%	-	
I <sub>o</sub> =1050 mA	91.0%	93.0%	-	
ESM-240S150Dx				Measured at 100%load and steady-state temperature in 25°C ambient; (Efficiency will be about 2.0% lower if measured immediately after startup.)
I <sub>o</sub> =1050 mA	90.5%	92.5%	-	
I <sub>o</sub> =1500 mA	90.5%	92.5%	-	
ESM-240S350Dx				
I <sub>o</sub> =2150 mA	91.0%	93.0%	-	
I <sub>o</sub> =3500 mA	89.5%	91.5%	-	
ESM-240S670Dx				
I <sub>o</sub> =4200 mA	89.5%	91.5%	-	
I <sub>o</sub> =6700 mA	88.5%	90.5%	-	
Efficiency at 400 Vac input: ESM-240S105Dx				
I <sub>o</sub> = 700 mA	92.5%	94.5%	-	Measured at 100%load and steady-state temperature in 25°C ambient; (Efficiency will be about 2.0% lower if measured immediately after startup.)
I <sub>o</sub> =1050 mA	91.5%	93.5%	-	
ESM-240S150Dx				
I <sub>o</sub> =1050 mA	91.5%	93.5%	-	
I <sub>o</sub> =1500 mA	91.5%	93.5%	-	
ESM-240S350Dx				
I <sub>o</sub> =2150 mA	92.0%	94.0%	-	
I <sub>o</sub> =3500 mA	90.5%	92.5%	-	
ESM-240S670Dx				
I <sub>o</sub> =4200 mA	90.5%	92.5%	-	
I <sub>o</sub> =6700 mA	89.0%	91.0%	-	
Efficiency at 480 Vac input: ESM-240S105Dx				
I <sub>o</sub> = 700 mA	92.5%	94.5%	-	Measured at 100%load and steady-state temperature in 25°C ambient; (Efficiency will be about 2.0% lower if measured immediately after startup.)
I <sub>o</sub> =1050 mA	92.0%	94.0%	-	
ESM-240S150Dx				
I <sub>o</sub> =1050 mA	92.0%	94.0%	-	
I <sub>o</sub> =1500 mA	91.5%	93.5%	-	
ESM-240S350Dx				
I <sub>o</sub> =2150 mA	92.0%	94.0%	-	
I <sub>o</sub> =3500 mA	91.0%	93.0%	-	
ESM-240S670Dx				
I <sub>o</sub> =4200 mA	91.0%	93.0%	-	
I <sub>o</sub> =6700 mA	89.5%	91.5%	-	
MTBF	-	240,000 Hours	-	Measured at 480Vac input, 80%load and 25°C ambient temperature (MIL-HDBK-217F)
Lifetime	-	100,000 Hours	-	Measured at 480Vac input, 80%load and 70°C case temperature; See lifetime vs. Tc curve for the details
Operating Case Temperature for Safety Tc_s	-40°C	-	+90°C	
Operating Case Temperature for Warranty Tc_w	-40°C	-	+80°C	Case temperature for 5 years warranty Humidity: 10% RH to 95% RH
Storage Temperature	-40°C	-	+85°C	Humidity: 5%RH to 95%RH
Dimensions:				With mounting ear
Inches (L × W × H)	7.91 × 2.66 × 1.52			8.58 × 2.66 × 1.52
Millimeters (L × W × H)	201 × 67.5 × 38.5			218 × 67.5 × 38.5
Net Weight	-	1120 g	-	

## Dimming Specifications

Parameter		Min.	Typ.	Max.	Notes
Absolute Maximum Voltage on the Vdim (+) Pin		-20 V	-	20 V	
Source Current on Vdim (+)Pin		200 $\mu$ A	300 $\mu$ A	450 $\mu$ A	Vdim(+) = 0 V
Dimming Output Range	ESM-240S105Dx ESM-240S150Dx ESM-240S350Dx ESM-240S670Dx	10%loset	-	loset	700 mA $\leq$ loiset $\leq$ 1050 mA 1050 mA $\leq$ loiset $\leq$ 1500 mA 2150 mA $\leq$ loiset $\leq$ 3500 mA 4200 mA $\leq$ loiset $\leq$ 6700 mA
	ESM-240S105Dx ESM-240S150Dx ESM-240S350Dx ESM-240S670Dx	70 mA 105 mA 215 mA 420 mA	-	loiset	70 mA $\leq$ loiset < 700 mA 105 mA $\leq$ loiset < 1050 mA 215 mA $\leq$ loiset < 2150 mA 420 mA $\leq$ loiset < 4200 mA
Recommended Dimming Range for 1-10V		1 V	-	9 V	Default 1-10V dimming mode with positive logic.
PWM_in High Level		-	10V	-	
PWM_in Low Level		-	0V	-	
PWM_in Frequency Range		200 Hz	-	2 KHz	
PWM_in Duty Cycle		0%	-	100%	

## Safety &EMC Compliance

Safety Category	Standard
UL/CUL	UL 8750,CAN/CSA-C22.2 No. 250.13
ENEC & CE	EN 61347-1, EN 61347-2-13
CB	IEC 61347-1, IEC 61347-2-13
EAC	TP TC 004, TP TC 020
Performance	Standard
ENEC	EN IEC 62384
EMI Standards	Notes
EN IEC 55015 <sup>(1)</sup>	Conducted emission Test &Radiated emission Test
EN IEC 61000-3-2	Harmonic current emissions
EN 61000-3-3	Voltage fluctuations & flicker
FCC Part 15 <sup>(1)</sup>	ANSI C63.4 Class B
	This device complies with Part 15 of the FCC Rules. Operation is subject to the following two conditions: [1] this device may not cause harmful interference, and [2] this device must accept any interference received, including interference that may cause undesired operation.

## Safety & EMC Compliance (Continued)

EMS Standards	Notes
EN 61000-4-2	Electrostatic Discharge (ESD): 8 kV air discharge, 4 kV contact discharge
EN 61000-4-3	Radio-Frequency Electromagnetic Field Susceptibility Test-RS
EN 61000-4-4	Electrical Fast Transient / Burst-EFT
EN 61000-4-5	Surge Immunity Test: AC Power Line: Differential Mode 6 kV, Common Mode 10 kV
EN 61000-4-6	Conducted Radio Frequency Disturbances Test-CS
EN 61000-4-8	Power Frequency Magnetic Field Test
EN 61000-4-11	Voltage Dips
EN 61547	Electromagnetic Immunity Requirements Applies To Lighting Equipment

**Note:** (1) This LED driver meets the EMI specifications above, but EMI performance of a luminaire that contains it depends also on the other devices connected to the driver and on the fixture itself.

## Lifetime vs. Case Temperature

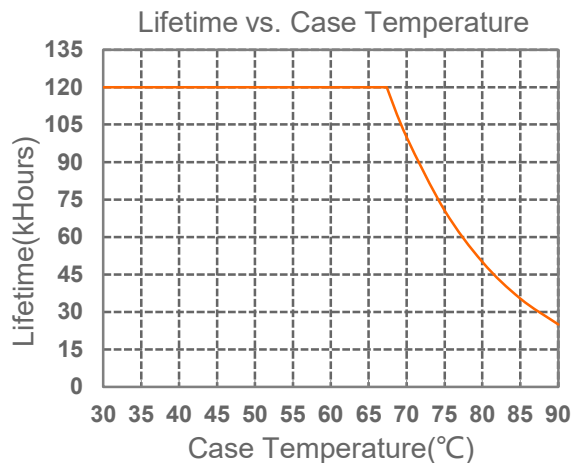

## Inrush Current Waveform

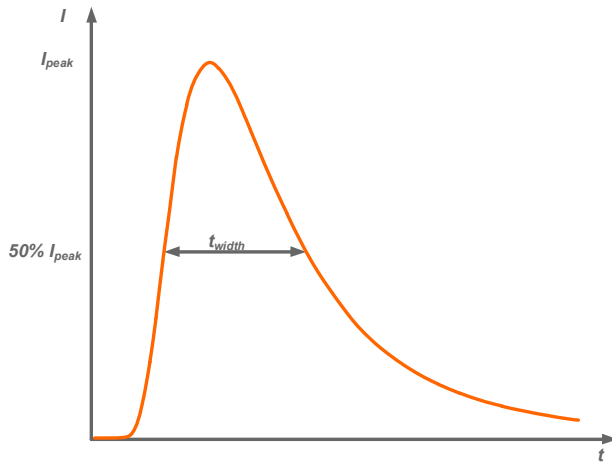

Input AC Voltage	$I_{peak}$	$t_{width}$ (@ 50% $I_{peak}$ )
480Vac	73.3A	192 $\mu$ s

## Efficiency vs. Load

ESM-240S105Dx ( $I_o=700mA$ )

Efficiency vs. Output Voltage

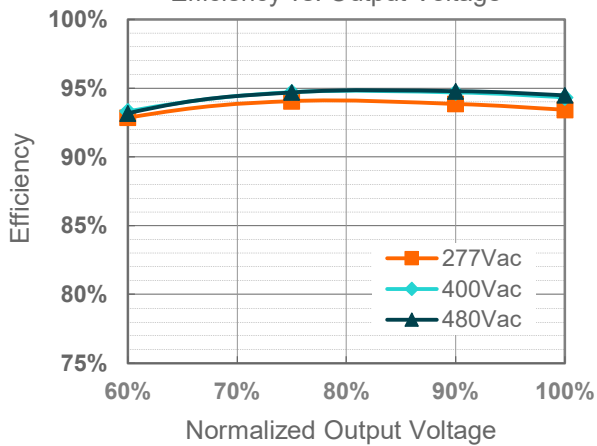

ESM-240S105Dx ( $I_o=1050mA$ )

Efficiency vs. Output Voltage

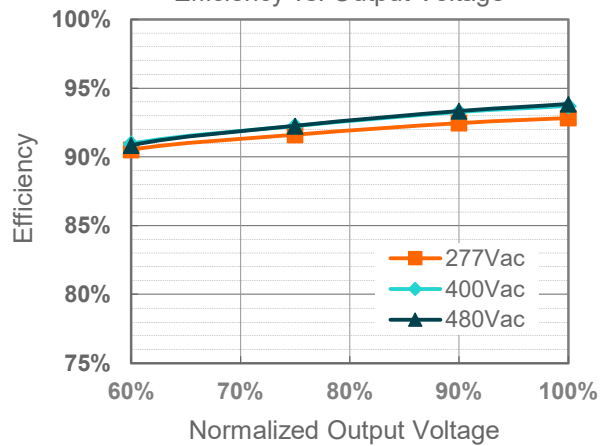

ESM-240S150Dx ( $I_o=1050mA$ )

Efficiency vs. Output Voltage

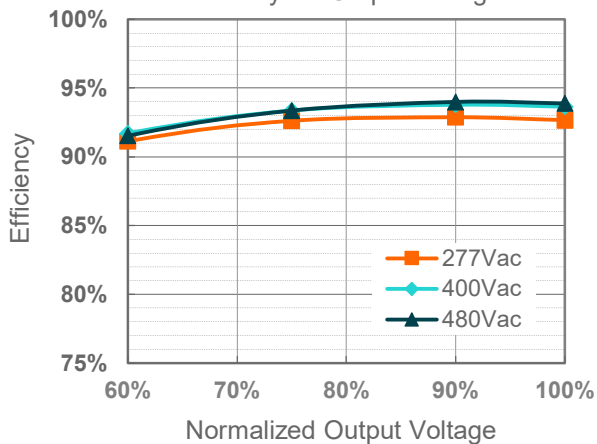

ESM-240S150Dx ( $I_o=1500mA$ )

Efficiency vs. Output Voltage

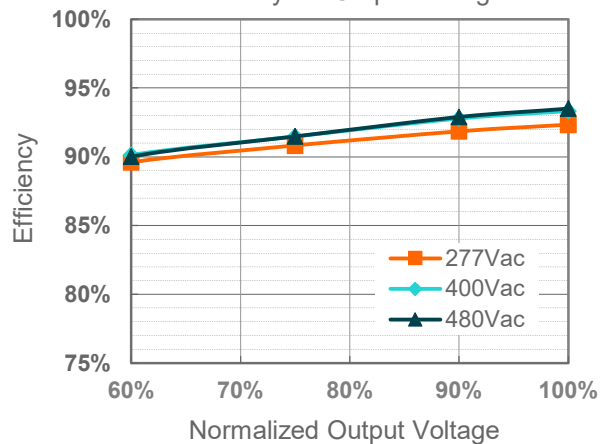

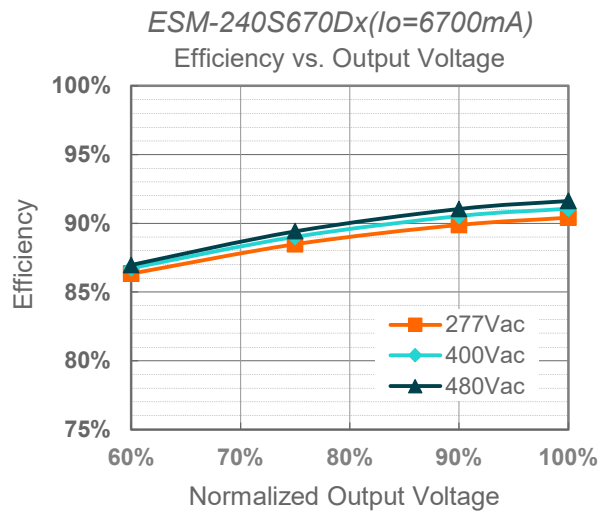
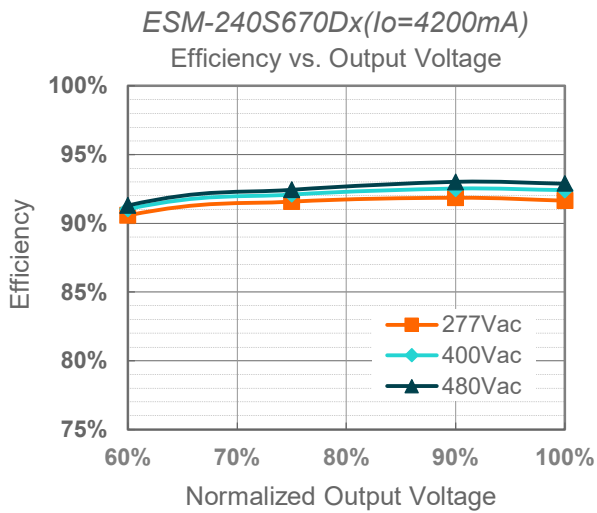
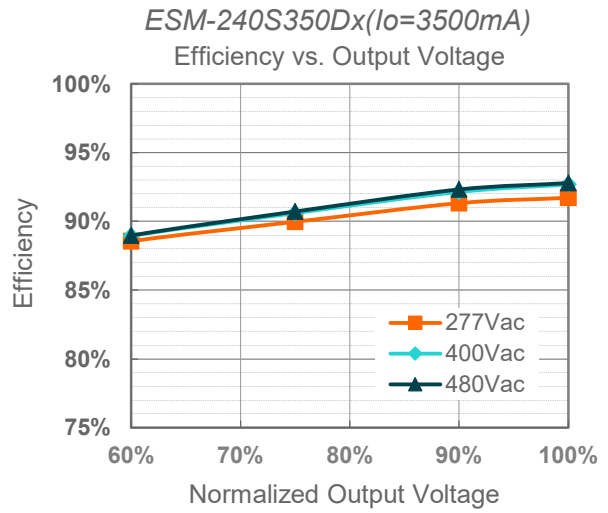
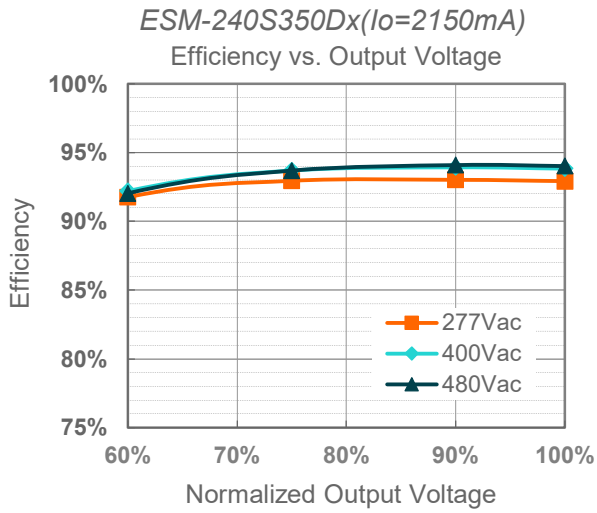

## Power Factor

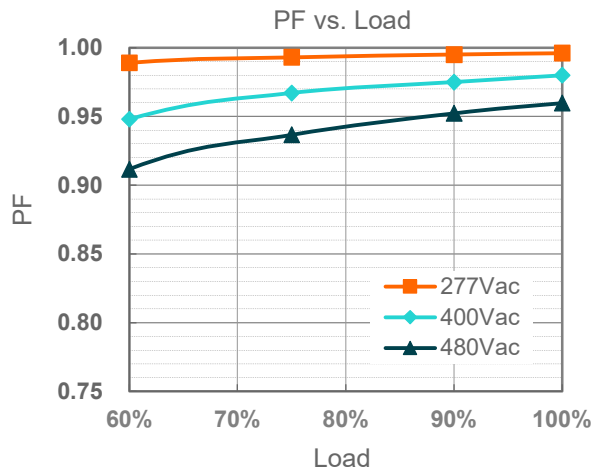

## Total Harmonic Distortion

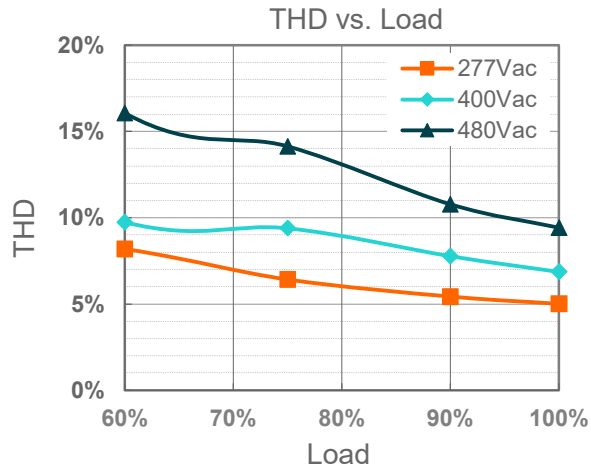

## Protection Functions

Parameter	Notes
Over Voltage Protection	Limits output voltage at no load and in case the normal voltage limit fails.
Short Circuit Protection	Auto Recovery. No damage will occur when any output is short circuited. The output shall return to normal when the fault condition is removed.
Over Temperature Protection	Decreases output current, returning to normal after over temperature is removed.

## Dimming

### ● 1-10V Dimming

The recommended implementation of the dimming control is provided below.

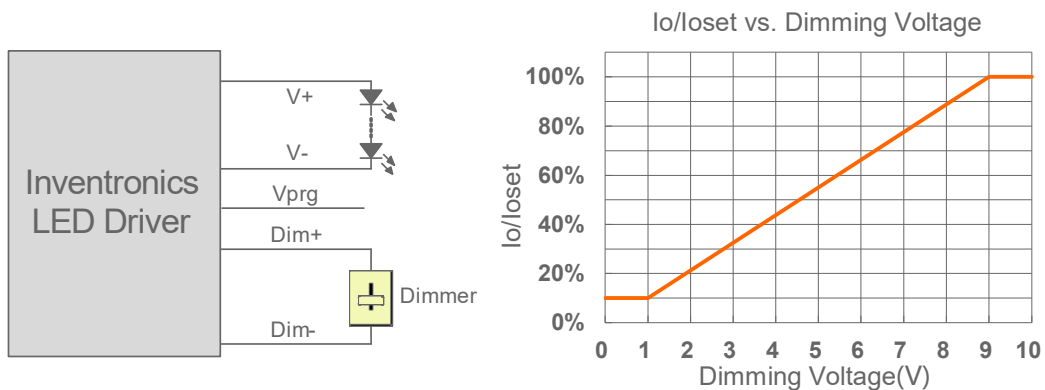

Implementation 1: Positive logic

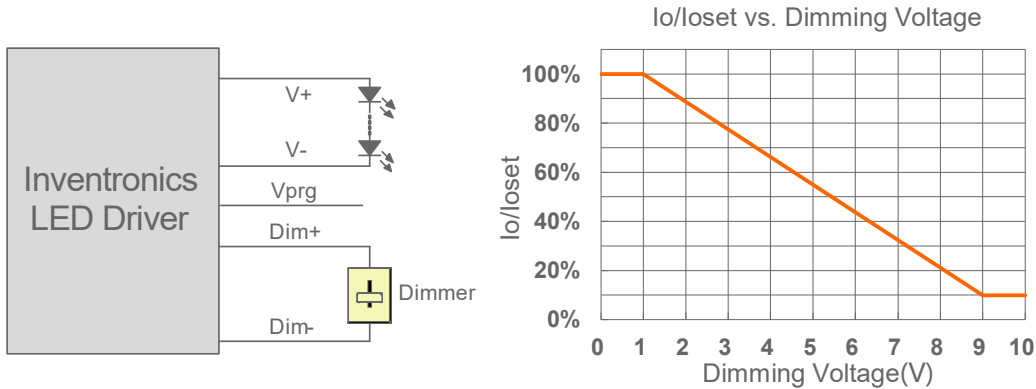

**Implementation 2: Negative logic**

**Notes:**

1. Do NOT connect Dim- to the output V- or V+, otherwise the driver will not work properly.
2. The dimmer can also be replaced by an active 1-10V voltage source signal or passive components like zener.
3. When 1-10V negative logic dimming mode and Dim+ is open, the driver will output minimum current.

● **10V PWM Dimming**

The recommended implementation of the dimming control is provided below.

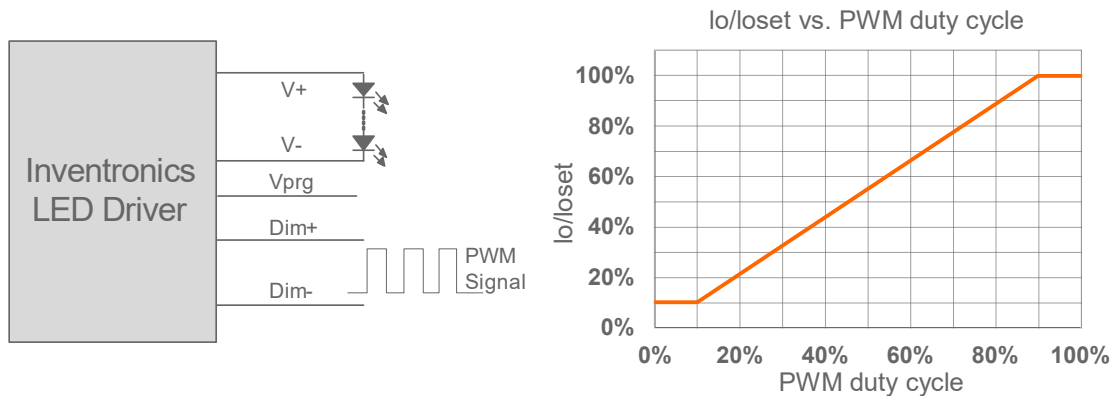

**Implementation 3: Positive logic**

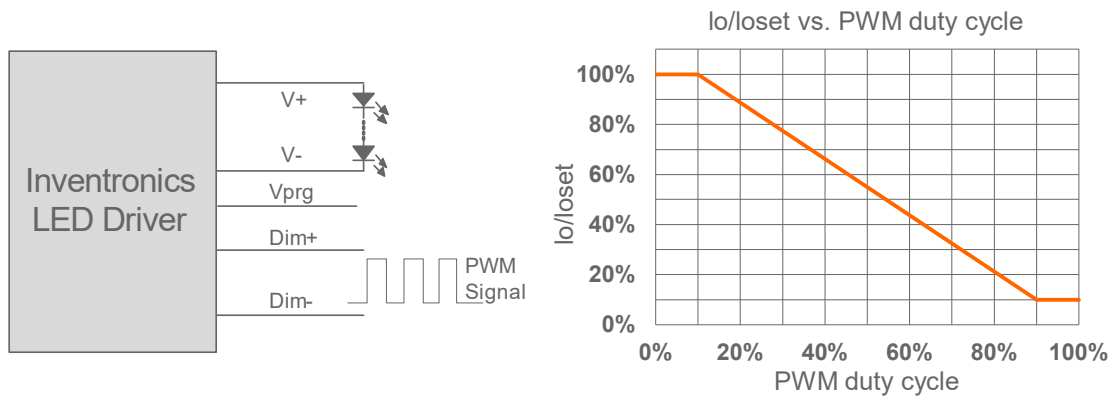

**Implementation 4: Negative logic**

**Notes:**

1. Do NOT connect Dim- to the output V- or V+, otherwise the driver will not work properly.
2. When 10V PWM negative logic dimming mode and Dim+ is open, the driver will output minimum current.

● **Time Dimming**

Time dimming control includes 3 kinds of modes, they are Self Adapting-Midnight, Self Adapting-Percentage and Traditional Timer.

- **Self Adapting-Midnight:** Automatically adjusts the dimming curve based on the on-time of past two days (if difference <15 minutes), assuming that the center point of the dimming curve is midnight local time.
- **Self Adapting-Percentage:** Automatically adjusts the on-time of each step by a constant percentage = (actual on-time for the past 2 days if difference <15 min) / (programmed on-time from the dimming curve).
- **Traditional Timer:** Follows the programmed timing curve after power on with no changes.

● **Output Lumen Compensation**

Output Lumen Compensation (OLC) may be used to maintain constant light output over the life of the LEDs by driving them at a reduced current when new, then gradually increasing the drive current over time to counteract LED lumen degradation.

● **End Of Life**

End-of-Life (EOL) is providing a visual notification to a user that the LED module has reached the end of manufacturer-specified life and that the replacement is recommended. Once active, an indication is given at each power-up of the driver, which the driver indicates this through a lower light output during the first 1 minute before normal operation is continued.

**Programming Connection Diagram**

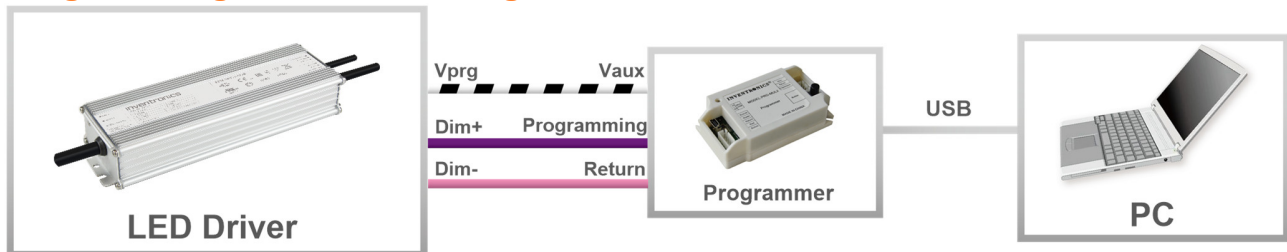

**Note:** The driver does not need to be powered on during the programming process.

- Please refer to [PRG-MUL2 \(Programmer\) datasheet](#) for details.

## Mechanical Outline

### ESM-240SxxxDG

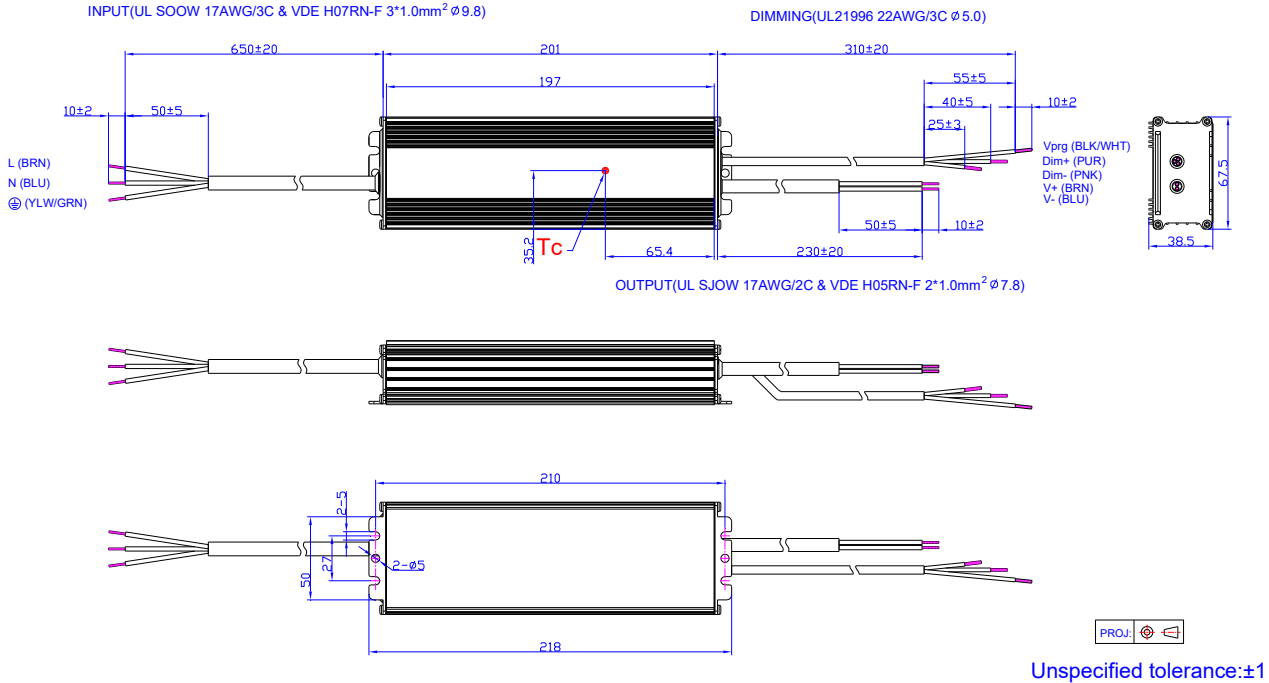

### ESM-240SxxxDT

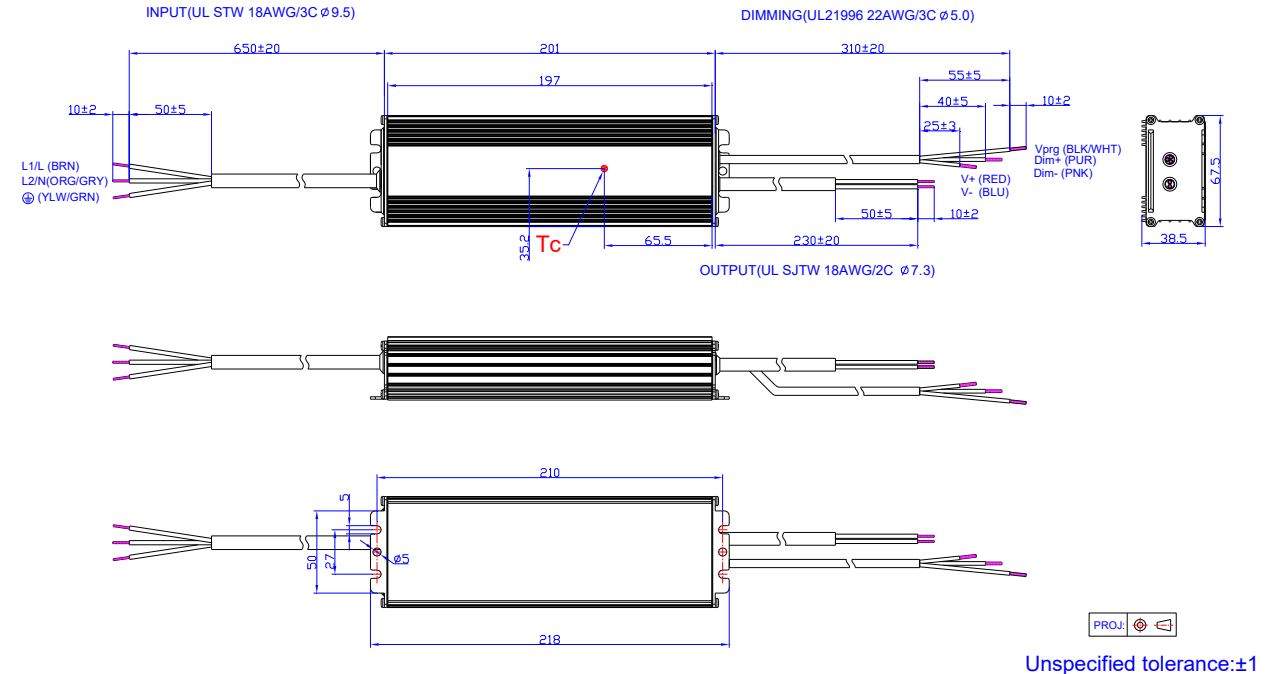

## RoHS Compliance

Our products comply with reference to RoHS Directive (EU) 2015/863 amending 2011/65/EU, calling for the elimination of lead and other hazardous substances from electronic products.

## Revision History

Change Date	Rev.	Description of Change		
		Item	From	To
2020-07-09	A	Datasheet Release	/	/
2022-01-15	B	UKCA / EAC logo	/	Added
		Safety &EMC Compliance	/	Updated
		Programming Connection Diagram	/	Updated
		Mechanical Outline	ESM-240SxxxDT	Updated
2023-07-05	C	Product Photograph	/	Updated
		Safety &EMC Compliance	/	Updated
		Dimming	/	Updated
		Programming Connection Diagram	/	Updated
		Mechanical Outline	/	Updated
2026-03-10	D	Format	/	Updated
		Product Photograph	/	Updated
		UKCA logo	/	Deleted
		Safety &EMC Compliance	/	Updated
		Inrush Current Waveform	/	Updated