

Features

- 0 -10V Dimmable (Compatible with Passive Dimmers)
- Constant Current Output
- High Efficiency
- Active Power Factor Correction
- All-Around Protection: OVP, SCP and Open Lamp Protection
- Class 2 & SELV Output



Description

The LUC-018SxxxDSP(SSP) series operates from a 90 ~ 305 Vac input range. They are designed to be highly efficient and reliable. Features include over voltage, short circuit and open lamp protections.

Models

Output Current	Input Voltage Range(1)	Output Voltage Range	Max. Output Power	Typical Efficiency (2)	Typical Power Factor (2)	Model Number
350 mA	90 ~ 305 Vac	26~ 51 Vdc	18 W	85%	0.94	LUC-018S035DSP(SSP) ⁽³⁾
500 mA	90 ~ 305 Vac	18~ 36 Vdc	18 W	85%	0.94	LUC-018S050DSP(SSP) ⁽⁴⁾
700 mA	90 ~ 305 Vac	13~ 26 Vdc	18 W	84%	0.94	LUC-018S070DSP(SSP) ⁽⁴⁾
1050 mA	90 ~ 305 Vac	9 ~ 17 Vdc	18 W	82%	0.94	LUC-018S105DSP(SSP) ⁽⁴⁾

Notes: (1) Certified input voltage range: UL 100-277Vac; otherwise: 100-240Vac.

(2) Measured in 220 Vac input at 100% load.

(3) Class 2 (USR), Non-Class 2 (CNR).

(4) Class 2 (USR & CNR).

Input Specifications

Parameter	Min.	Typ.	Max.	Notes
Input AC Voltage	90 Vac	-	305 Vac	
Input Frequency	47 Hz	-	63 Hz	
Leakage Current	-	-	0.75 MIU	UL 8750; 277Vac/ 60Hz
	-	-	0.70 mA	IEC 60598-1; 240Vac/ 60Hz
Input AC Current	-	-	0.28 A	Measured at 100% load and 100 Vac input
	-	-	0.12 A	Measured at 100% load and 220 Vac input
Inrush Current(I ² t)	-	-	0.18 A ² s	At 220Vac input, 25°C cold start, duration=176 μs, 10%I _{pk} -10%I _{pk} . See Inrush Current Waveform for the details.
Power Factor	0.90	-	-	At 100-277Vac, 50-60Hz, 75%-100% load (13.5-18W)
THD	-	-	20%	

Output Specifications

Parameter	Min.	Typ.	Max.	Notes
Output Current Tolerance	-5%Io	-	5%Io	At 100% load condition.
Output Current Ripple(pk-pk)	-	30%Io	50%Io	At 100% load condition.
No load Output Voltage				
Io = 350 mA	-	-	59.1 V	
Io = 500 mA	-	-	42 V	
Io = 700 mA	-	-	34 V	
Io = 1050 mA	-	-	24 V	
Startup Overshoot Current	-	-	10%Io	At 100% load condition.
Line Regulation	-	-	±1%	Measured at 100% load.
Load Regulation	-	-	±3%	Measured at 100% load.
Turn-on Delay Time	-	0.4 s	0.75 s	Measured at 100% load 120Vac input.
	-	0.4 s	0.6 s	Measured at 100% load 220Vac input.
Temperature Coefficient of Iomax	-	0.03%/°C	-	Case temperature = 0°C ~Tc max
12V Auxiliary Output Voltage	10.5 V	12 V	12.5 V	
12V Auxiliary Output Source Current	-	-	60 mA	60%~100% load, return terminal is "Dim-"
	-	-	5 mA	50%~60% load, return terminal is "Dim-"

Note: All specifications are tested by Cree XLamp XP-G unless otherwise stated.

General Specifications

Parameter	Min.	Typ.	Max.	Notes
Efficiency at 120 Vac input:				
Io = 350 mA	83%	84%	-	Measured at 100% load and steady-state temperature in 25°C ambient.
Io = 500 mA	83%	84%	-	
Io = 700 mA	82%	83%	-	
Io = 1050 mA	80%	81%	-	
Efficiency at 220 Vac input:				
Io = 350 mA	84%	85%	-	Measured at 100% load and steady-state temperature in 25°C ambient.
Io = 500 mA	84%	85%	-	
Io = 700 mA	83%	84%	-	
Io = 1050 mA	81%	82%	-	
Efficiency at 277 Vac input:				
Io = 350 mA	83%	84%	-	Measured at 100% load and steady-state temperature in 25°C ambient.
Io = 500 mA	83%	84%	-	
Io = 700 mA	82%	83%	-	
Io = 1050 mA	80%	81%	-	
No Load Power Dissipation	-	-	1 W	
MTBF	-	235,900 Hours	-	Measured at 120Vac input, 80%load and 25°C ambient temperature (MIL-HDBK-217F)
Lifetime	-	113,000 Hours	-	Measured at 120Vac input, 80%load and 60°Ccase temperature, See life time vs. Tc curve for more details

General Specifications (Continued)

Parameter	Min.	Typ.	Max.	Notes
Operating Case Temperature for Safety T _{c s}	-20°C	-	+90°C	
Operating Case Temperature for Warranty T _{c w}	-20°C	-	+70°C	Humidity: 10% RH to 100% RH No condensation
Storage Temperature	-20°C	-	+85°C	Humidity: 5% RH to 100% RH No condensation
Dimensions Inches (L × W × H) Millimeters (L × W × H)	4.72 × 1.65 × 1.20 120 × 42 × 30.5			
Net Weight	-	200 g	-	

Note: All specifications are tested by Cree XLamp XP-G unless otherwise stated.

Dimming Specifications

Parameter	Min.	Typ.	Max.	Notes
Absolute Maximum Voltage on the V _{dim} (+) Pin	-20 V	-	20 V	
Source Current on V _{dim} (+) Pin	0 μA	200 μA	250 μA	
Dimming Output Range	10% I _{omax}	-	100% I _{omax}	
Recommended Dimming Input Range	0 V	-	10 V	

Safety & EMC Compliance

Safety Category	Standard
UL/CUL	UL 8750, UL 1310, CAN/CSA-C22.2 No. 250.13, CAN/CSA-C22.2 No. 223-M91
CE	EN 61347-1, EN61347-2-13
KS	KS C 7655
EMI Standards	Notes
EN IEC 55015 ⁽¹⁾ /CISPR15	Conducted Emission Test & Radiated Emission Test
EN IEC 61000-3-2	Harmonic Current Emissions Class C
EN 61000-3-3	Voltage Fluctuations & Flicker
EMS Standards	Notes
EN 61000-4-2	Electrostatic Discharge (ESD): 8 kV air discharge, 4 kV contact discharge Level 3, Criteria A
EN 61000-4-3	Radio-Frequency Electromagnetic Field Susceptibility Test-RS Level 3, Criteria A
EN 61000-4-4	Electrical Fast Transient / Burst-EFT
EN 61000-4-5	Surge Immunity Test: AC Power Line: Differential Mode 1 kV
EN 61000-4-6	Conducted Radio Frequency Disturbances Test-CS Level 3, Criteria A

Safety & EMC Compliance (Continued)

EMS Standards	Notes
EN 61000-4-8	Power Frequency Magnetic Field Test 3A/m , Criteria A
EN 61000-4-11	Voltage Dips Criteria B
EN IEC 61547	Electromagnetic Immunity Requirements Applies to Lighting Equipment

Note: (1) This LED driver meets the EMI specifications above, but EMI performance of a luminaire that contains it depends also on the other devices connected to the driver and on the fixture itself.

Lifetime vs. Case Temperature

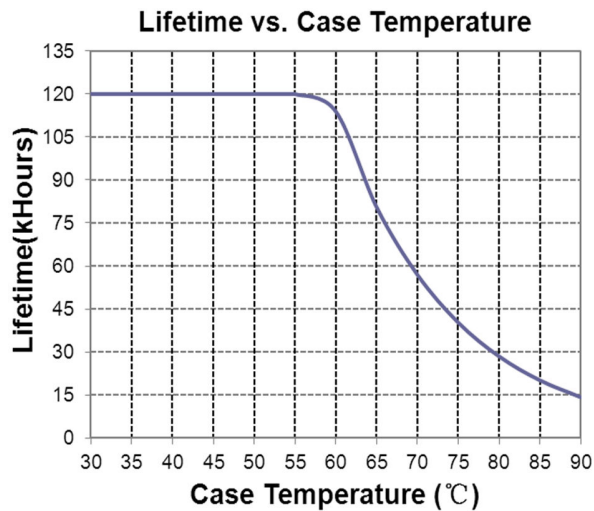

Inrush Current Waveform

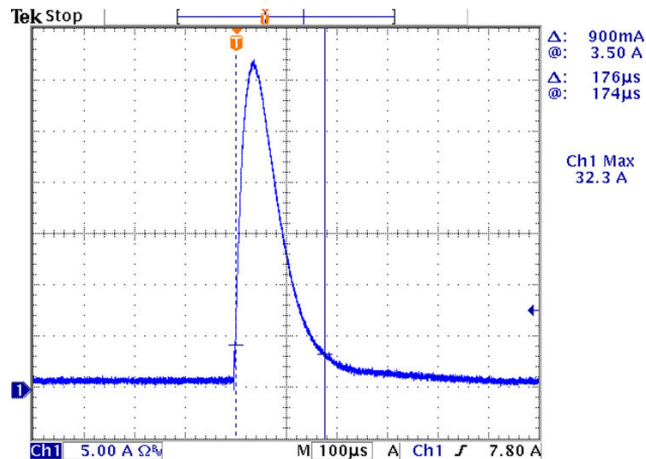

Efficiency vs. Load

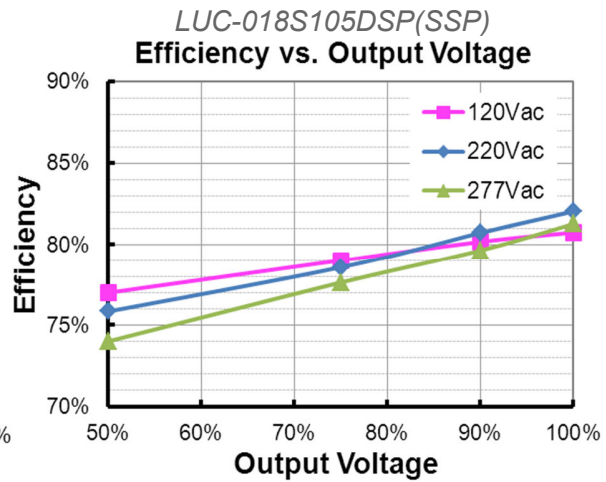
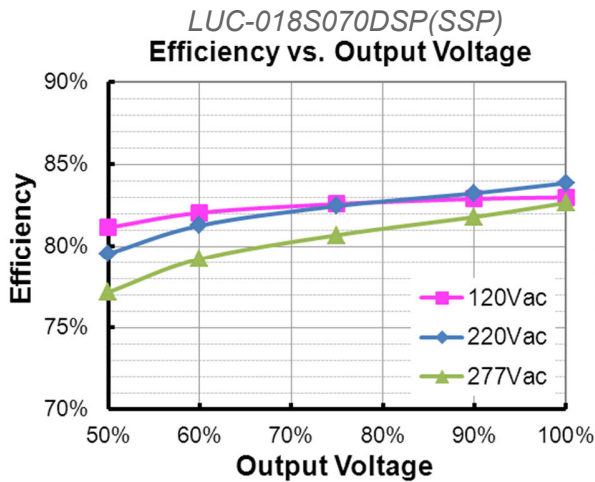
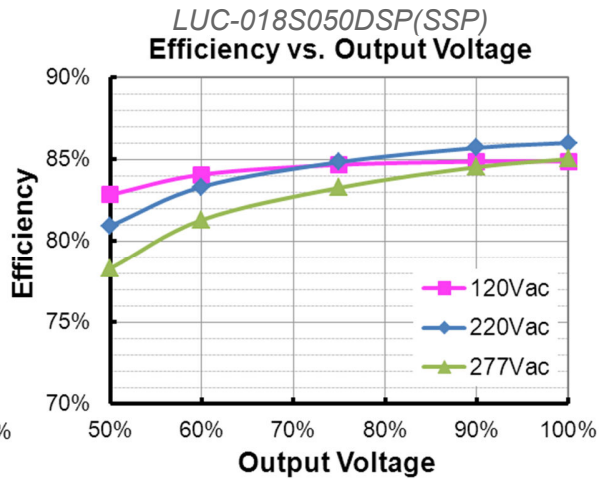
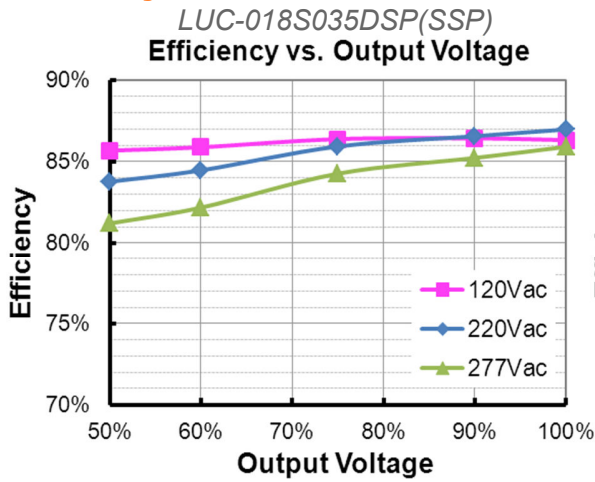

Power Factor

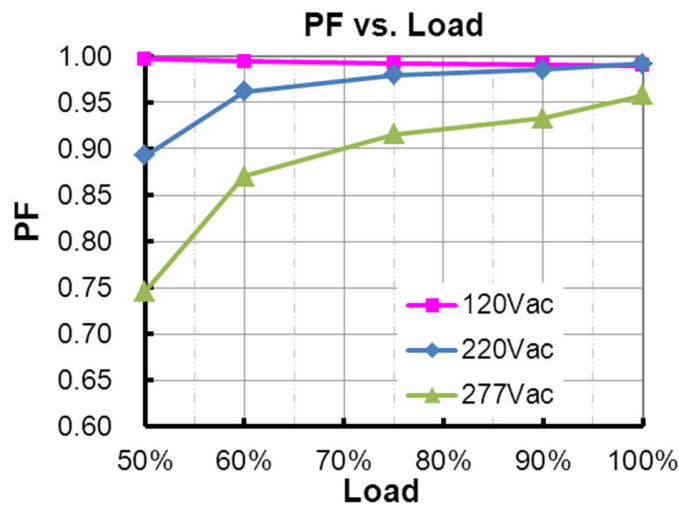

Total Harmonic Distortion

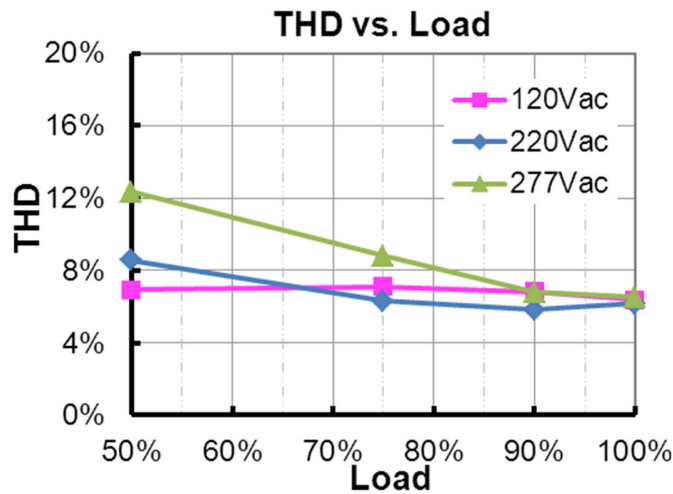

Protection Functions

Parameter	Notes
Over Voltage Protection	Limits output voltage at no load and in case the normal voltage limit fails.
Short Circuit Protection	Auto Recovery. No damage shall occur when any output operating in a short circuit condition. The power supply shall be self-recovery when the fault condition is removed.

Dimming

● 0-10V Dimming

The dimmer control may be operated from either a dimmer or from an input signal of 0 – 10Vdc. The recommended implementations of the dimming control are provided below.

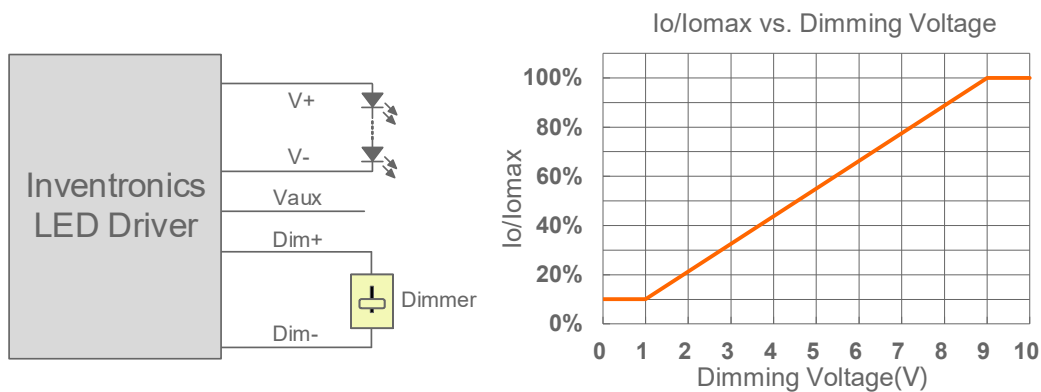

Implementation 1: DC Input

Note: If 0-10V dimming is not used, Dim + can be either open or connected to Vaux.

Mechanical Outline

LUC-018SxxxDSP

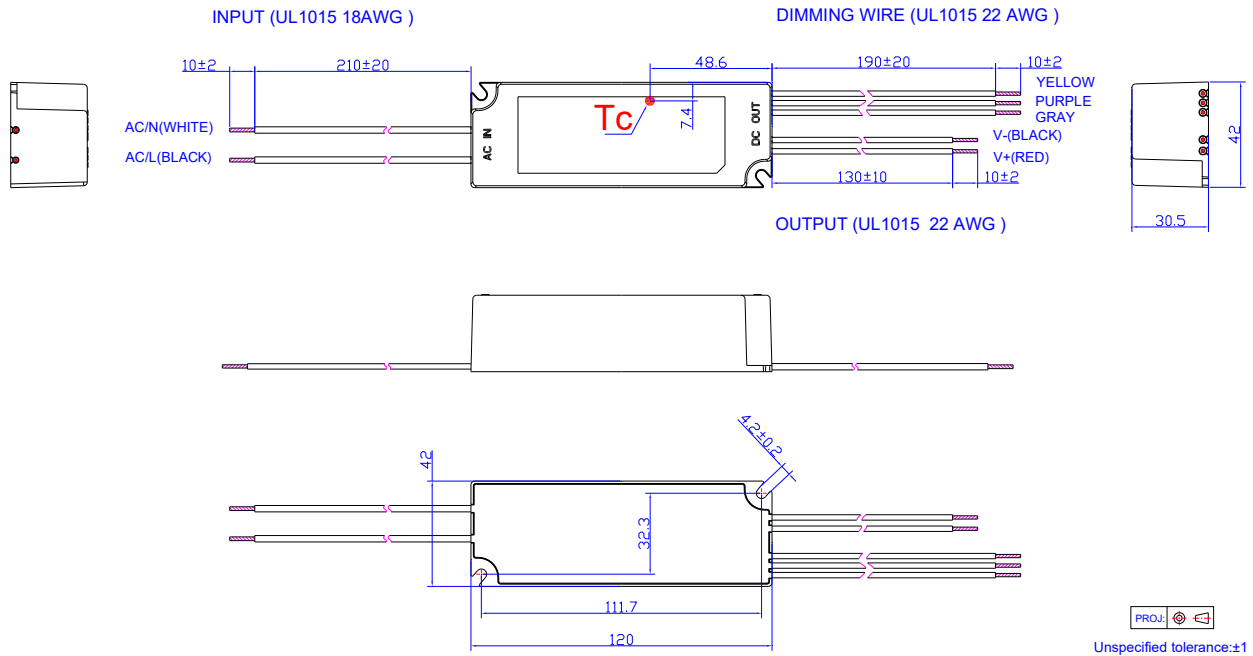

LUC-018SxxxSSP

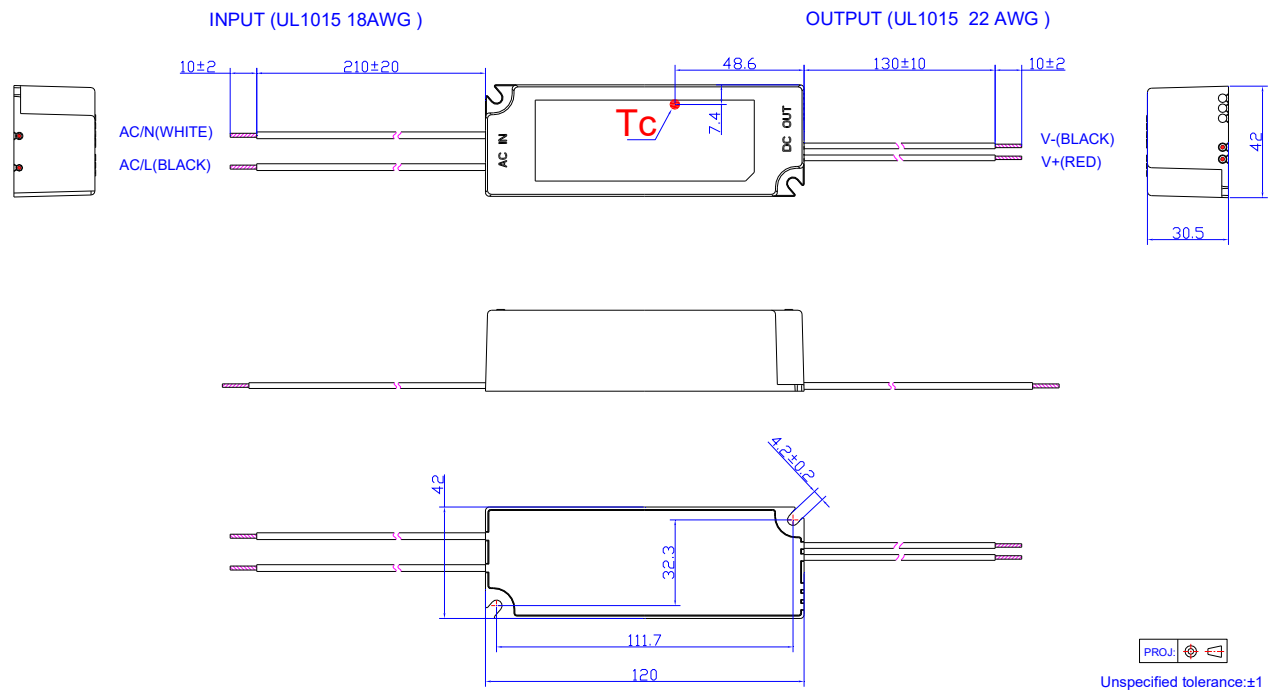

RoHS Compliance

Our products comply with reference to RoHS Directive (EU) 2015/863 amending 2011/65/EU, calling for the elimination of lead and other hazardous substances from electronic products.

Revision History

Change Date	Rev.	Description of Change		
		Item	From	To
2012-04-01	A	Datasheet Released	/	/
2012-07-17	B	Max Case Temperature 90 °C	/	Added
		Product Picture	/	Updated
		Mechanical Outline	/	Corrected
		12 V output voltage (Vaux) Min	11.5 V	10.5 V
2012-08-02	C	Details of No Load Voltage	/	Added
		Details of OVP	/	Added
2012-08-30	D	Inrush Current(I ² t)	/	Added
		Min PF	/	Added
		Max THD	/	Added
		Temperature coefficient	/	Added
2013-08-22	E	Min output voltage	60% Vomax	50%Vomax
		Dimming control-12 V source current	/	Corrected
		0~10V Wire Current Sourcing Capability	/	Updated
2015-08-11	F	Dimming Specifications-0~10V Wire Current Sourcing Capability Max.	210 uA	250 uA
		Inrush Current(I ² t)	0.11 A ² s Max.	0.18 A ² s Max.
		Inrush Current Waveform	/	Added
		Efficiency vs. Load Curve	/	Updated
		Power Factor Curve	/	Updated
		Total Harmonic Distortion Curve	/	Added
		Operating Case Temperature for Warranty Tc_w	/	Added
		Environmental Specifications	/	Deleted
		Lifetime	61,900	113,000
		Lifetime vs. Case Temperature Curve	/	Updated
		Double Insulation	/	Added
		Leakage Current	/	Updated
Turn-on Delay Time at 220 Vac	/	Added		
2017-07-07	G	KS Certificate	/	Added
		Turn-on Delay Time at 120Vac	Max.=1.0 s	Max.=0.75 s
		Turn-on Delay Time at 220Vac	Max.=0.8 s	Max.=0.6 s
		Net Weight	190 g	200 g

Revision History (Continued)

Change Date	Rev.	Description of Change		
		Item	From	To
2017-07-07	G	Note of EMI Standard	/	Added
2023-05-24	H	PSE logo	/	Deleted
		TUV logo	/	Updated
		Safety & EMC Compliance	/	Updated
2026-04-14	I	Format	/	Updated
		Product Photograph	/	Updated
		FCC/TUV/CB logo	/	Deleted
		Models	/	Updated
		Safety & EMC Compliance	/	Updated