

Feature

- Ultra High Efficiency (Up to 94%)
- Full Power at Wide Output Current Range (Constant Power)
- 0-5V/0-10V/PWM/Timer Dimmable
- Input Surge Protection: DM 6kV, CM 10kV
- All-Around Protection: OVP, SCP, OTP
- IP67 and UL Dry / Damp / Wet Location
- SELV Output
- TYPE HL, for use in a Class I, Division 2 Hazardous (Classified) location
- UL Type TL (Temperature Limited)
- 7 Years Warranty



Description

The EUG-240SxxxDT series is a 240W, constant-current, programmable LED driver that operates from 90-305 Vac input with excellent power factor. It is created for many lighting applications including high bay, high mast, and roadway lights. The high efficiency of these drivers and compact metal case enables them to run cooler, significantly improving reliability and extending product life. To ensure trouble-free operation, protection is provided against input surge, output over voltage, short circuit, and over temperature.

Models

Adjustable Output Current Range (mA)	Full-Power Current Range (mA) ⁽¹⁾	Default Output Current (mA)	Output Voltage Range (Vdc)	Max. Output Power (W)	Typical Efficiency ⁽²⁾	Power Factor		Model Number ⁽³⁾⁽⁴⁾
						120Vac	220Vac	
70-1050	700-1050	700	114-343	240	94.0%	0.99	0.96	EUG-240S105DT
140-2100	1400-2100	1400	57-171	240	93.0%	0.99	0.96	EUG-240S210DT
280-4200	2800-4200	4200	29-86	240	93.0%	0.99	0.96	EUG-240S420DT ⁽⁵⁾
445-6700	4450-6700	6700	18-54	240	93.0%	0.99	0.96	EUG-240S670DT ⁽⁵⁾

Notes: (1) Output current range with constant power at 240W

(2) Measured at 100% load and 220Vac input (see below "General Specifications" for details).

(3) Certified voltage range: UL, FCC 100-277Vac or 127-300Vdc; otherwise 100-240Vac or 127-250Vdc (except KS)

(4) All the models are certificated to KS, except EUG-240S105DT

(5) SELV Output.

I-V Operating Area

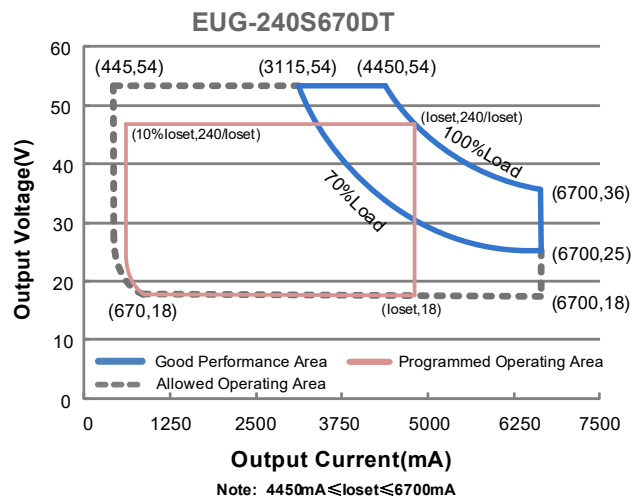
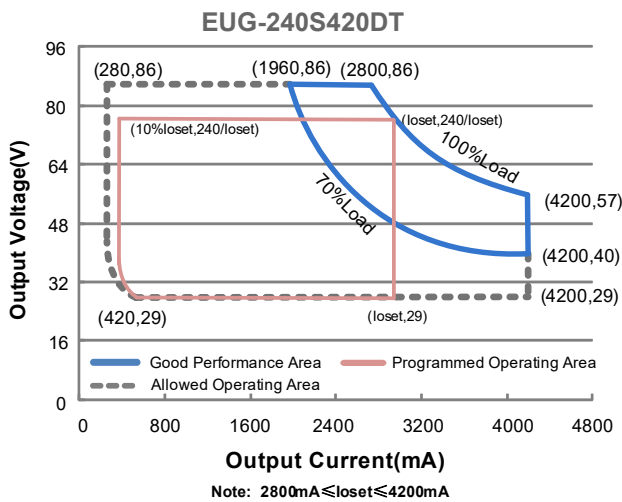
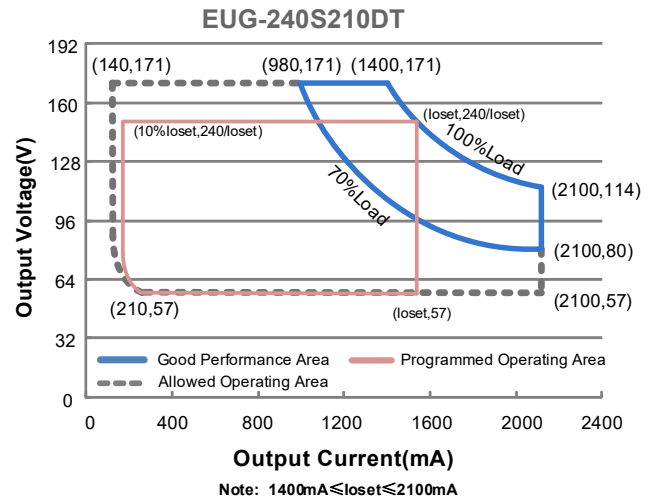
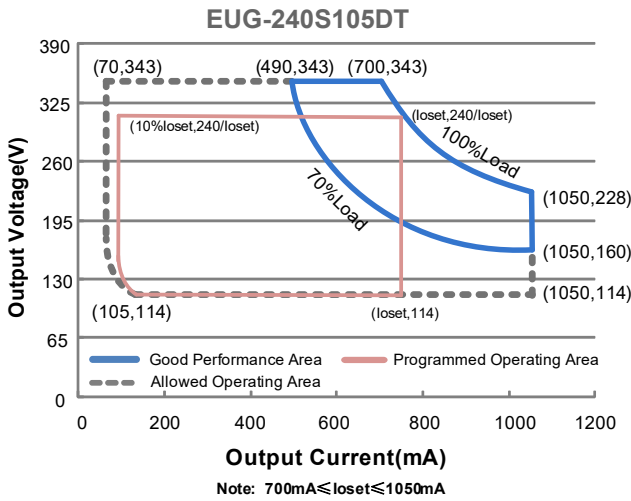

Input Specifications

Parameter	Min.	Typ.	Max.	Notes
Input AC Voltage	90 Vac	-	305 Vac	
Input DC Voltage	127 Vdc	-	300 Vdc	
Input Frequency	47 Hz	-	63 Hz	
Leakage Current	-	-	0.75 MIU	UL 8750; 277Vac/ 60Hz, grounding effectively
	-	-	0.70 mA	IEC 60598-1; 240Vac/ 60Hz, grounding effectively
Input AC Current	-	-	3.10 A	Measured at 100% load and 100 Vac input.
	-	-	1.40 A	Measured at 100% load and 220 Vac input.
Inrush Current(I ² t)	-	-	3.75 A ² s	At 220Vac input, 25°C cold start, duration=1.26 ms, 10%I _{pk} -10%I _{pk} . See Inrush Current Waveform for the details.

Input Specifications (Continued)

Parameter	Min.	Typ.	Max.	Notes
PF	0.9	-	-	At 100-277Vac, 50-60Hz, 70%-100% Load (168-240W)
THD	-	-	20%	
THD	-	-	10%	At 220-240Vac, 50-60Hz, 75%-100% Load (180-240W)

Output Specifications

Parameter	Min.	Typ.	Max.	Notes
Output Current Tolerance	-5%loset	-	5%loset	At 100% load condition
Output Current Setting(loset) Range				
EUG-240S105DT	70 mA	-	1050 mA	
EUG-240S210DT	140 mA	-	2100 mA	
EUG-240S420DT	280 mA	-	4200 mA	
EUG-240S670DT	445 mA	-	6700 mA	
Output Current Setting Range with Constant Power				
EUG-240S105DT	700 mA	-	1050 mA	
EUG-240S210DT	1400 mA	-	2100 mA	
EUG-240S420DT	2800 mA	-	4200 mA	
EUG-240S670DT	4450 mA	-	6700 mA	
Total Output Current Ripple (pk-pk)	-	5%lomax	10%lomax	At 100% load condition. 20 MHz BW
Output Current Ripple at < 200 Hz (pk-pk)	-	2%lomax	-	At 100% load condition. Only this component of ripple is associated with visible flicker.
Startup Overshoot Current	-	-	10%lomax	At 100% load condition
No Load Output Voltage				
EUG-240S105DT	-	-	356 V	
EUG-240S210DT	-	-	187 V	
EUG-240S420DT	-	-	96 V	
EUG-240S670DT	-	-	60 V	
Line Regulation	-	-	±0.5%	Measured at 100% load
Load Regulation	-	-	±1.5%	
Turn-on Delay Time	-	-	1.0 s	Measured at 120Vac input, 70%-100% Load
	-	-	0.5 s	Measured at 220Vac input, 70%-100% Load
Temperature Coefficient of loset	-	0.03%/°C	-	Case temperature = 0°C ~Tc max
12V Auxiliary Output Voltage	10.8 V	12 V	13.2 V	
12V Auxiliary Output Source Current	0 mA	-	20 mA	Return terminal is "Dim-"

General Specifications

Parameter	Min.	Typ.	Max.	Notes
Efficiency at 120 Vac input: EUG-240S105DT				Measured at 100% load and steady-state temperature in 25°C ambient; (Efficiency will be about 2.0% lower if measured immediately after startup.)
lo= 700 mA	90.0%	92.0%	-	
lo=1050 mA	88.5%	90.5%	-	
EUG-240S210DT				
lo=1400 mA	88.5%	90.5%	-	
lo=2100 mA	88.0%	90.0%	-	
EUG-240S420DT				
lo=2800 mA	89.0%	91.0%	-	
lo=4200 mA	87.0%	89.0%	-	
EUG-240S670DT				
lo=4450 mA	88.5%	90.5%	-	
lo=6700 mA	87.0%	89.0%	-	
Efficiency at 220 Vac input: EUG-240S105DT				Measured at 100% load and steady-state temperature in 25°C ambient; (Efficiency will be about 2.0% lower if measured immediately after startup.)
lo= 700 mA	92.0%	94.0%	-	
lo=1050 mA	90.5%	92.5%	-	
EUG-240S210DT				
lo=1400 mA	91.0%	93.0%	-	
lo=2100 mA	89.5%	91.5%	-	
EUG-240S420DT				
lo=2800 mA	91.0%	93.0%	-	
lo=4200 mA	89.5%	91.5%	-	
EUG-240S670DT				
lo=4450 mA	91.0%	93.0%	-	
lo=6700 mA	89.5%	91.5%	-	
Efficiency at 277 Vac input: EUG-240S105DT				Measured at 100% load and steady-state temperature in 25°C ambient; (Efficiency will be about 2.0% lower if measured immediately after startup.)
lo= 700 mA	92.5%	94.5%	-	
lo=1050 mA	91.0%	93.0%	-	
EUG-240S210DT				
lo=1400 mA	92.0%	94.0%	-	
lo=2100 mA	89.5%	91.5%	-	
EUG-240S420DT				
lo=2800 mA	91.5%	93.5%	-	
lo=4200 mA	90.0%	92.0%	-	
EUG-240S670DT				
lo=4450 mA	91.5%	93.5%	-	
lo=6700 mA	89.5%	91.5%	-	
MTBF	-	218,000 Hours	-	Measured at 220Vac input, 80%Load and 25°C ambient temperature (MIL-HDBK-217F)
Lifetime	-	109,000 Hours	-	Measured at 220Vac input, 80%Load and 70°C case temperature; See lifetime vs. Tc curve for the details
Operating Case Temperature for Safety Tc_s	-40°C	-	+88°C	
Operating Case Temperature for Warranty Tc_w	-40°C	-	+75°C	Case temperature for 7 years warranty. <i>Please see Inventronics Warranty Statement for complete details.</i>
Operating Case Temperature for Type TL Tc_TL	-40°C	-	+88°C	
Storage Temperature	-40°C	-	+85°C	Humidity: 5%RH to 100%RH

General Specifications (Continued)

Parameter	Min.	Typ.	Max.	Notes
Dimensions Inches (L × W × H) Millimeters (L × W × H)		8.35 × 2.66 × 1.56 212 × 67.5 × 39.7		With mounting ear 9.17 × 2.66 × 1.56 233 × 67.5 × 39.7
Net Weight	-	1200 g	-	

Dimming Specifications

Parameter	Min.	Typ.	Max.	Notes	
Absolute Maximum Voltage on the Vdim (+) Pin	-20 V	-	20 V		
Source Current on Vdim (+)Pin	200 uA	300 uA	450 uA	Vdim(+) = 0 V	
Dimming Output Range	EUG-240S105DT EUG-240S210DT EUG-240S420DT EUG-240S670DT	10%loset	-	loset	700 mA ≤ loset ≤ 1050 mA 1400 mA ≤ loset ≤ 2100 mA 2800 mA ≤ loset ≤ 4200 mA 4450 mA ≤ loset ≤ 6700 mA
	EUG-240S105DT EUG-240S210DT EUG-240S420DT EUG-240S670DT	70 mA 140 mA 280 mA 445 mA	-	loset	70 mA ≤ loset < 700 mA 140 mA ≤ loset < 1400 mA 280 mA ≤ loset < 2800 mA 445 mA ≤ loset < 4450 mA
Recommended Dimming Range for 0-5V	0 V	-	5 V	Dimming mode set to 0-5V in Inventronics Programing Software.	
Recommended Dimming Range for 0-10V	0 V	-	10 V	Default 0-10V dimming mode with positive logic.	
PWM_in High Level	3 V	-	10 V	Dimming mode set to PWM in Inventronics Programing Software.	
PWM_in Low Level	-0.3 V	-	0.6 V		
PWM_in Frequency Range	200 Hz	-	2 KHz		
PWM_in Duty Cycle	1%	-	99%		

Safety & EMC Compliance

Safety Category	Standard
UL/CUL	UL 8750,CAN/CSA-C22.2 No. 250.13
CE	EN 61347-1, EN 61347-2-13
CB	IEC 61347-1, IEC 61347-2-13
KS	KS C 7655
EMI Standards	Notes
EN IEC 55015/KS C 9815 ⁽¹⁾	Conducted emission Test &Radiated emission Test
EN IEC 61000-3-2	Harmonic current emissions
EN 61000-3-3	Voltage fluctuations & flicker

Safety & EMC Compliance (Continued)

EMI Standards	Notes
FCC Part 15 ⁽¹⁾	ANSI C63.4 Class B
	This device complies with Part 15 of the FCC Rules. Operation is subject to the following two conditions: [1] this device may not cause harmful interference, and [2] this device must accept any interference received, including interference that may cause undesired Operation.
EMS Standards	Notes
EN 61000-4-2	Electrostatic Discharge (ESD): 8 kV air discharge, 4 kV contact discharge
EN 61000-4-3	Radio-Frequency Electromagnetic Field Susceptibility Test-RS
EN 61000-4-4	Electrical Fast Transient / Burst-EFT
EN 61000-4-5	Surge Immunity Test: AC Power Line: Differential Mode 6 kV, Common Mode 10 kV ⁽²⁾
EN 61000-4-6	Conducted Radio Frequency Disturbances Test-CS
EN 61000-4-8	Power Frequency Magnetic Field Test
EN 61000-4-11	Voltage Dips
EN 61547/KS C 9547	Electromagnetic Immunity Requirements Applies To Lighting Equipment

Note: (1) This LED driver meets the EMI specifications above, but EMI performance of a luminaire that contains it depends also on the other devices connected to the driver and on the fixture itself.

(2) To perform electric strength (hi-pot) testing, the “GDT ground disconnect” (nut and metal lock sheet) on the driver end-cap should be removed temporarily to prevent the internal gas discharge tube from conducting (as allowed by IEC 60598-1 Clause 10.2). After testing is completed, these items must be reinstalled to restore line-to-earth surge protection and secure the end cap.

Derating

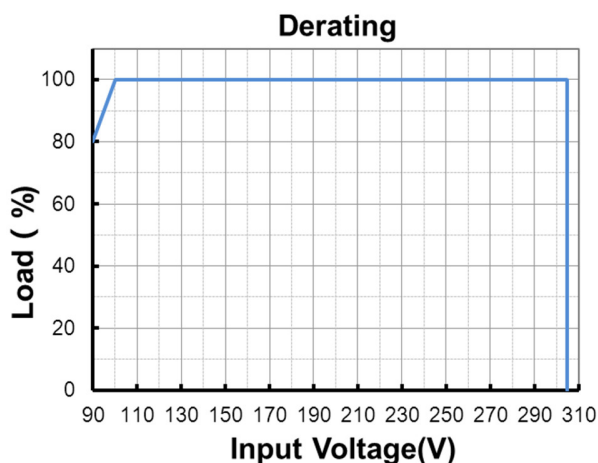

Lifetime vs. Case Temperature

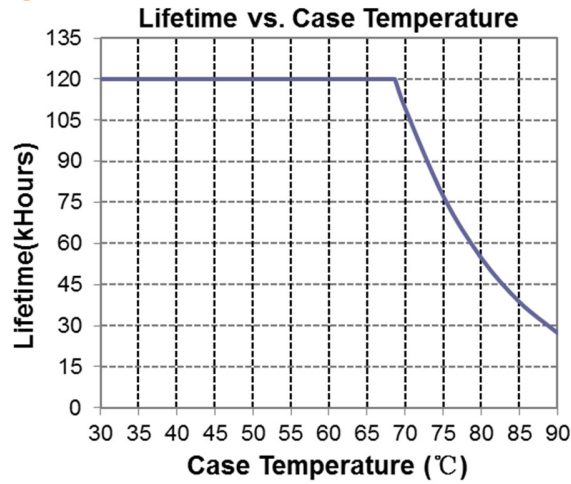

Inrush Current Waveform

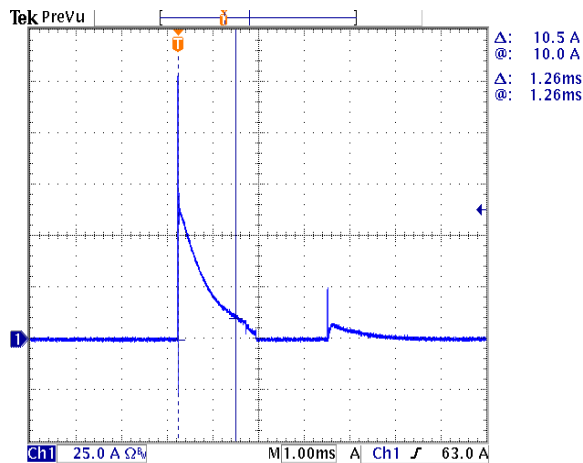

Efficiency vs. Load

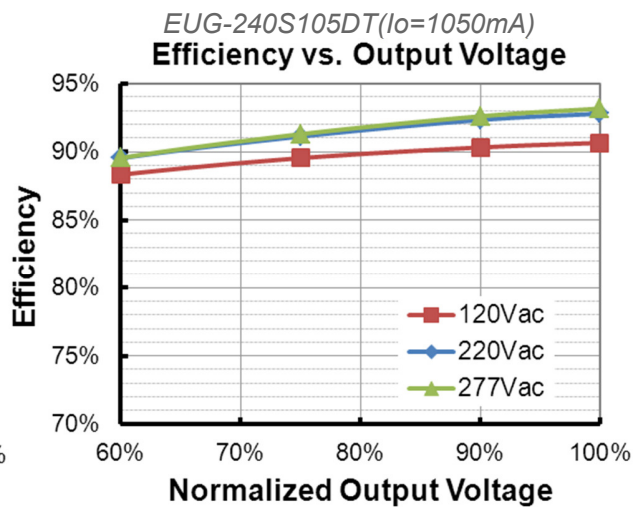
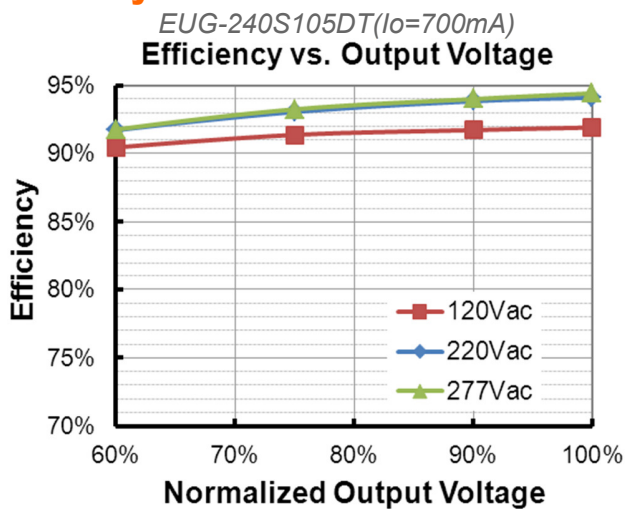

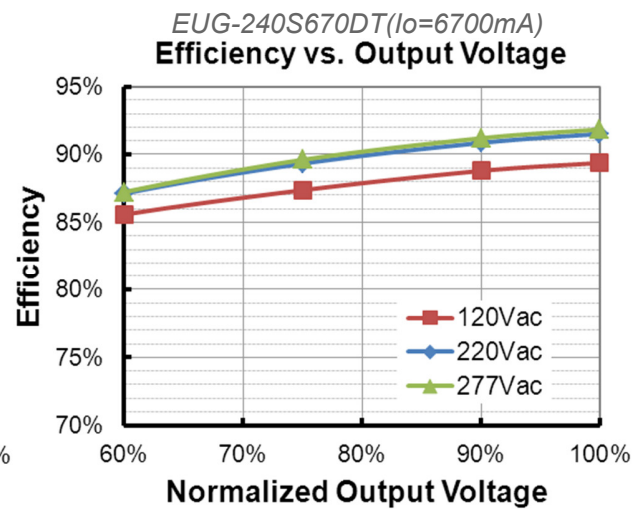
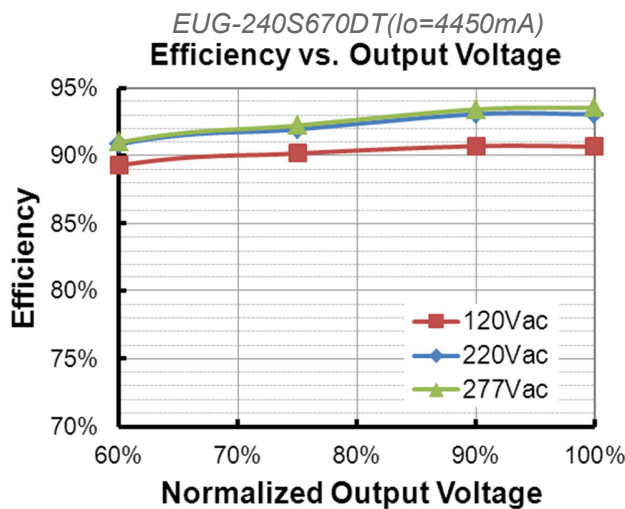
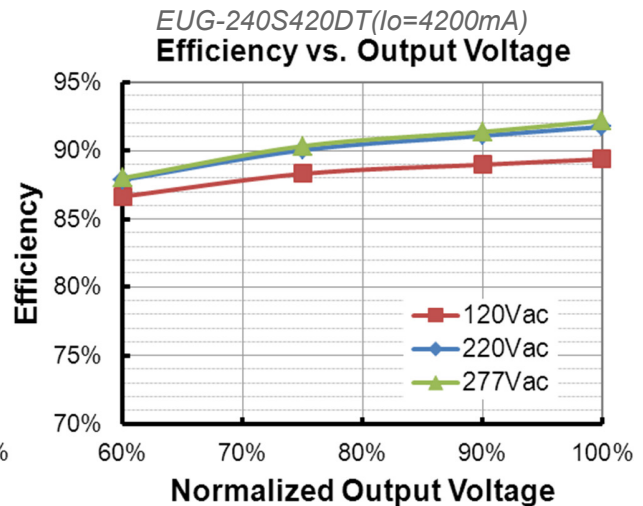
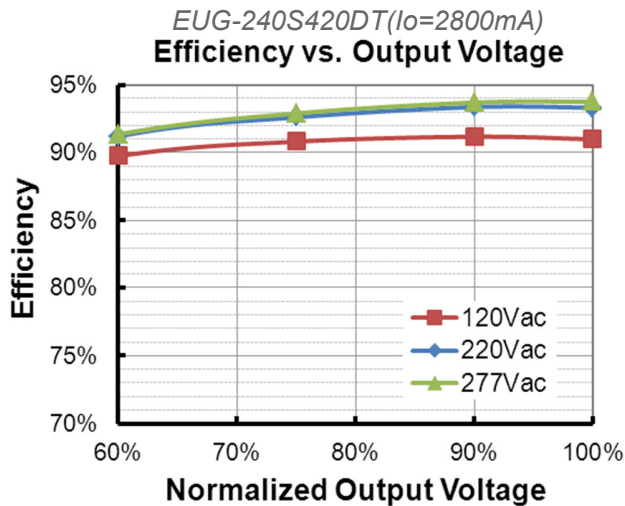
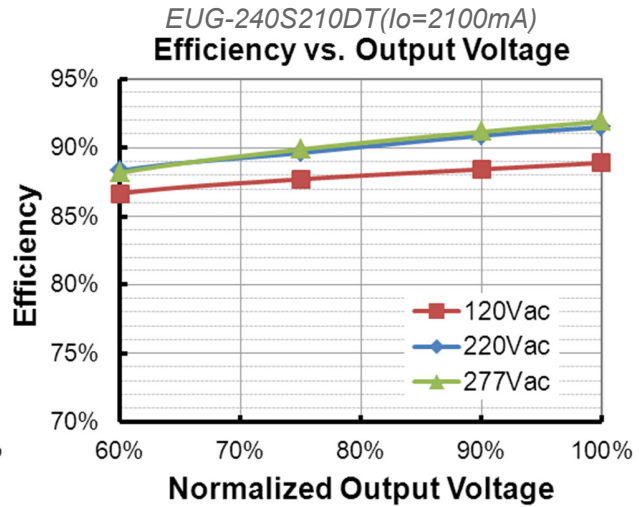
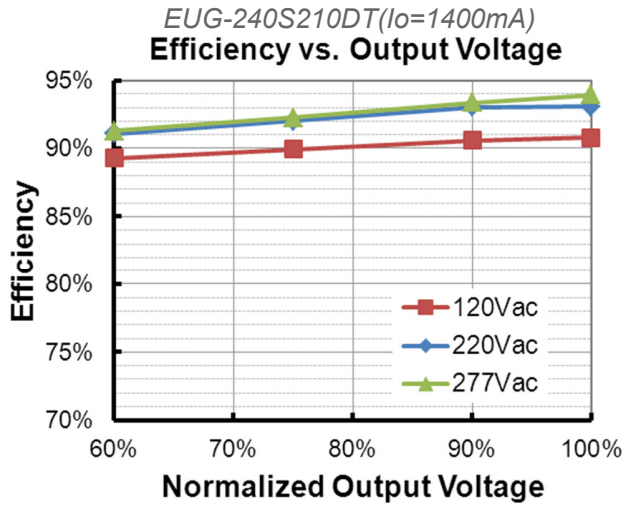

Power Factor

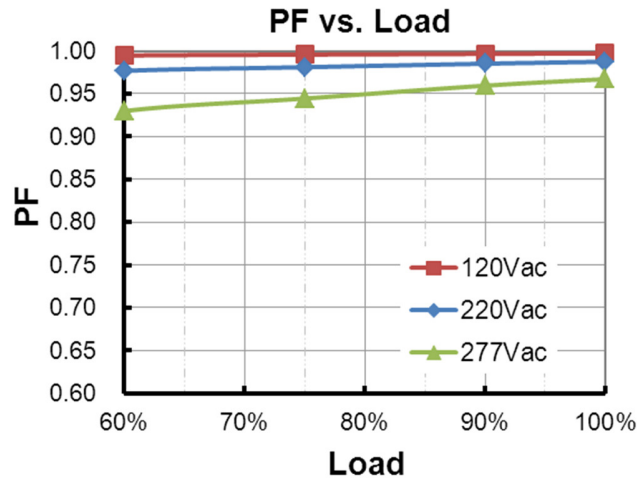

Total Harmonic Distortion

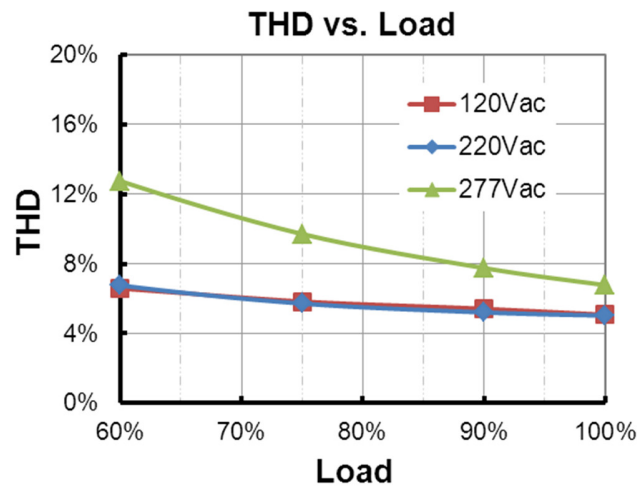

Protection Functions

Parameter	Notes
Over Temperature Protection	Decreases output current, returning to normal after over temperature is removed.
Short Circuit Protection	Auto Recovery. No damage will occur when any output is short circuited. The output shall return to normal when the fault condition is removed.
Over Voltage Protection	Limits output voltage at no load and in case the normal voltage limit fails.

Dimming

● 0-5V Dimming

The recommended implementation of the dimming control is provided below.

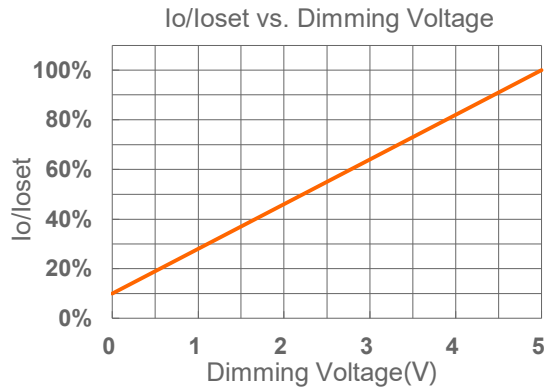
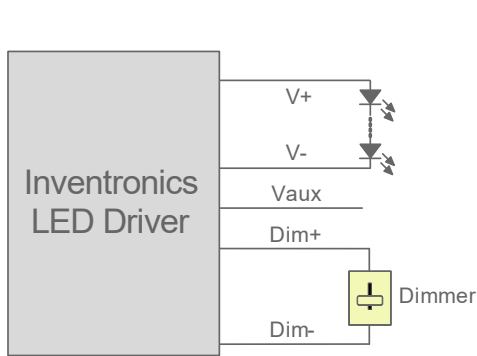

Implementation 1: Positive logic

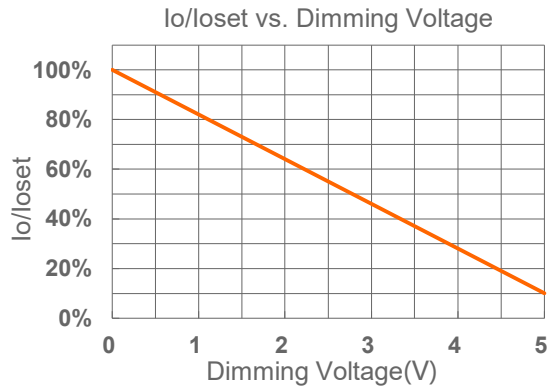
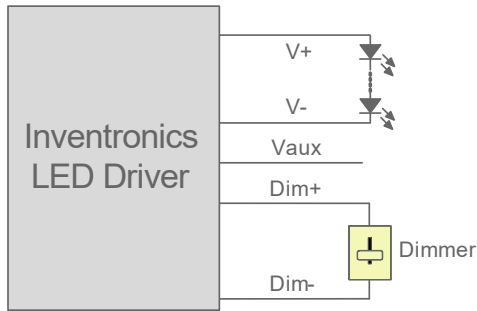

Implementation 2: Negative logic

Notes:

1. Do NOT connect Dim- to the output V- or V+, otherwise the driver will not work properly.
2. The dimmer can also be replaced by an active 0-5V voltage source signal or passive components like zener.
3. When 0-5V negative logic dimming mode and Dim+ is open, the driver will output maximum current.

● **0-10V Dimming**

The recommended implementation of the dimming control is provided below.

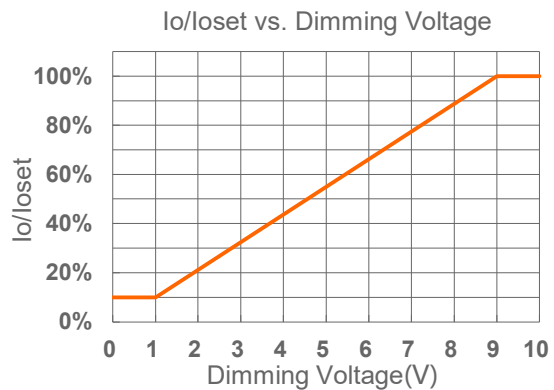
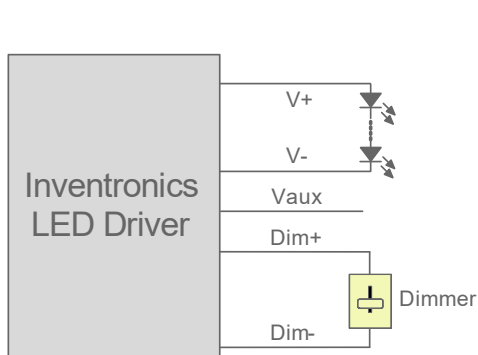

Implementation 3: Positive logic

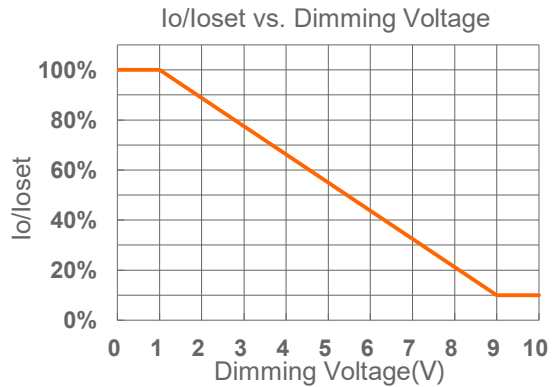
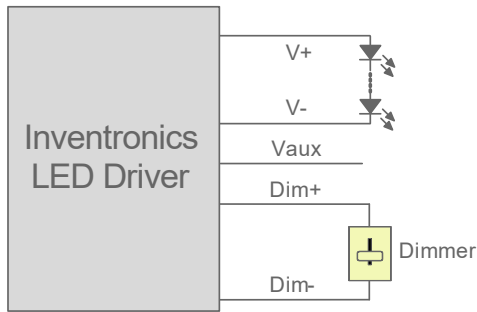

Implementation 4: Negative logic

Notes:

1. Do NOT connect Dim- to the output V- or V+, otherwise the driver will not work properly.
2. The dimmer can also be replaced by an active 0-10V voltage source signal or passive components like zener.
3. When 0-10V negative logic dimming mode and Dim+ is open, the driver will output minimum current.

● **PWM Dimming**

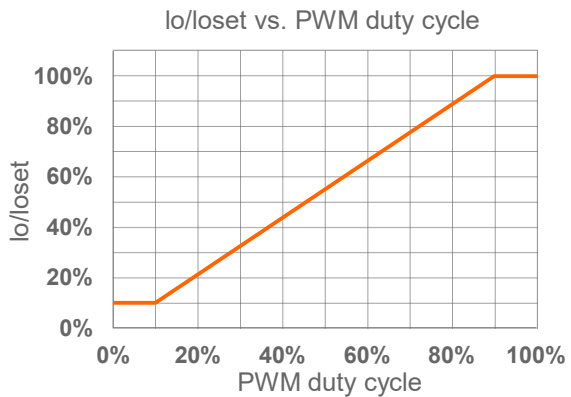
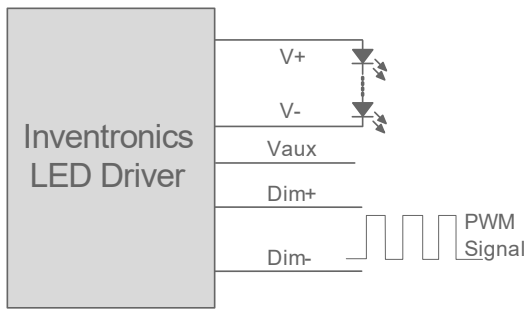

Implementation 5: Positive logic

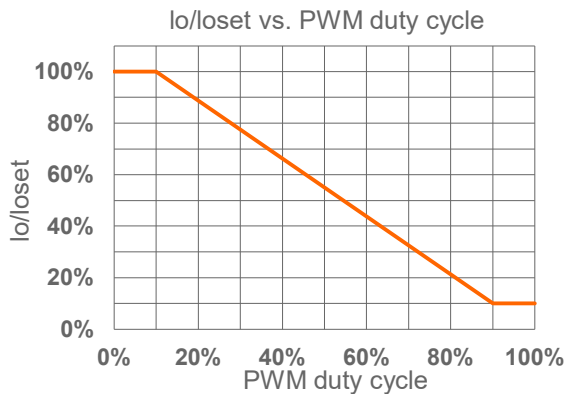
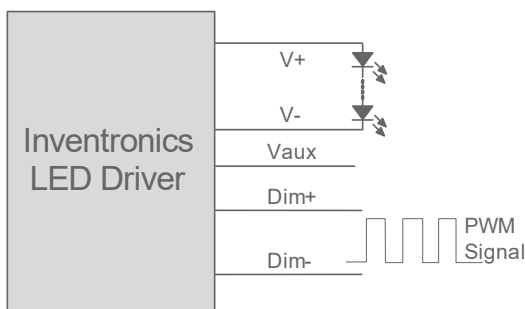

Implementation 6: Negative logic

Notes:

1. Do NOT connect Dim- to the output V- or V+, otherwise the driver will not work properly.
2. When PWM negative logic dimming mode and Dim+ is open, the driver will output minimum current.

● Time Dimming

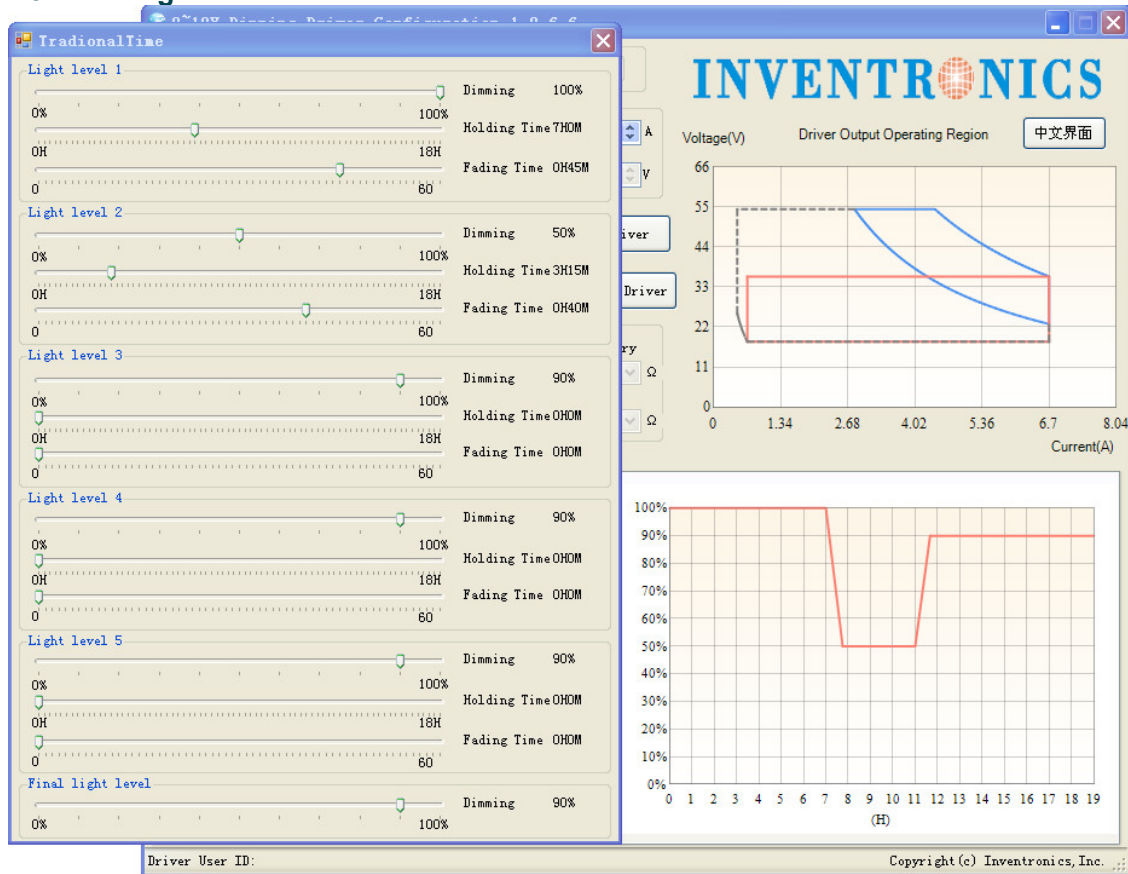

Set the timing curve by pulling the sliders.

Programming Connection Diagram

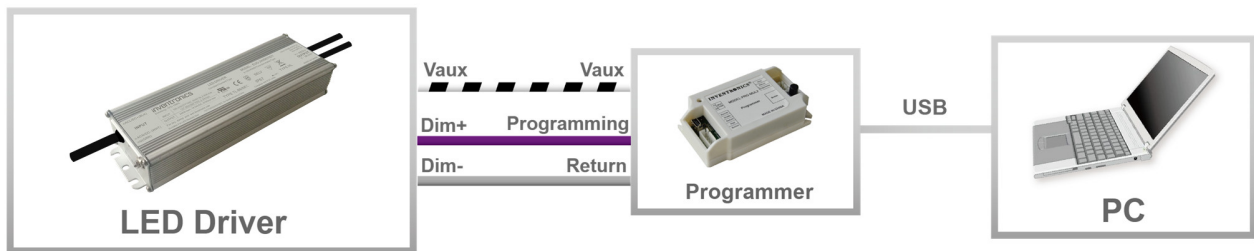

Note: The driver does not need to be powered on during the programming process.

- Please refer to [PRG-MUL2](#) (Programmer) datasheet for details.

Mechanical Outline

EUG-240S105DT

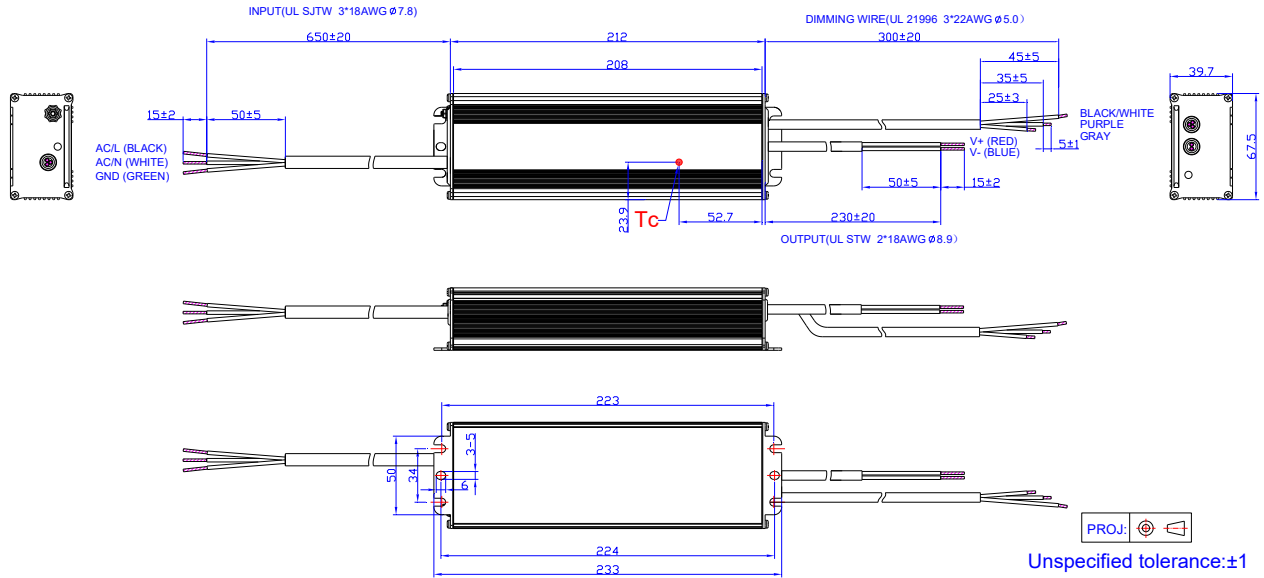

Others

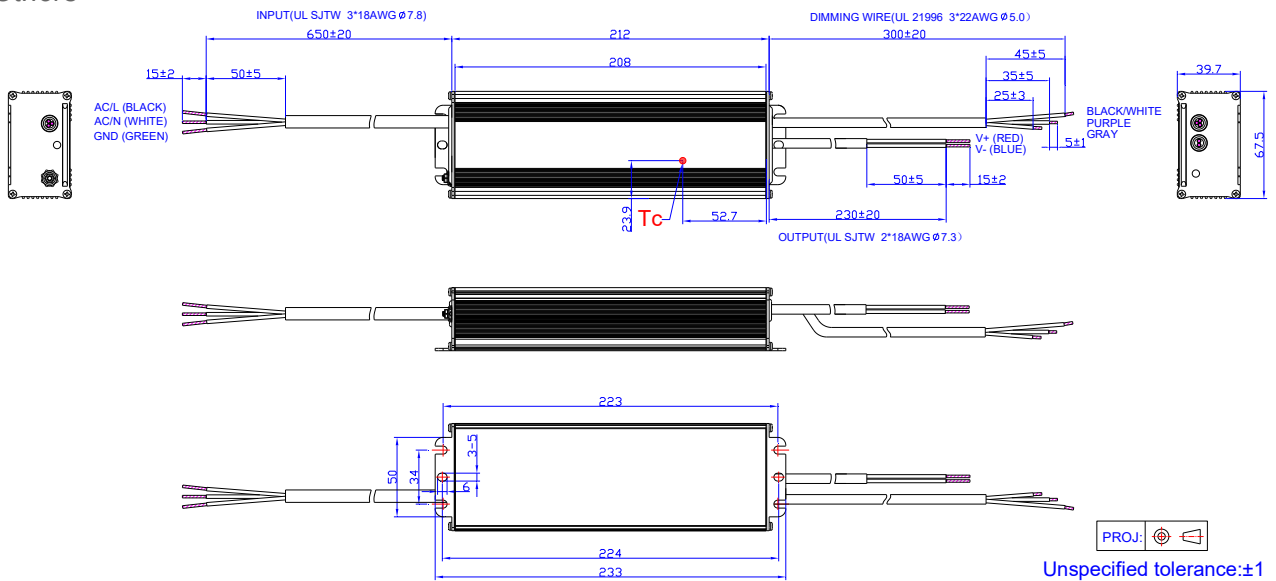

RoHS Compliance

Our products comply with reference to RoHS Directive (EU) 2015/863 amending 2011/65/EU, calling for the elimination of lead and other hazardous substances from electronic products.

Revision History

Change Date	Rev.	Description of Change		
		Item	From	To
2016-02-29	A	Datasheets Release	/	/
2016-04-08	B	Feature	/	Updated
		General Specifications	Operating Case Temperature for Type TL Tc_TL	Added
		General Specifications	With mounting ear	Updated
		Safety & EMC Compliance	/	Updated
		Mechanical Outline	/	Updated
2017-07-04	C	Feature	/	Updated
		Models	/	Updated
		Temperature Coefficient of loset	/	Updated
		Dimensions	/	Updated
		Safety & EMC Compliance	/	Updated
		Mechanical Outline	/	Updated
2017-10-26	D	Features	7 Years Warranty	Added
		Operating Case Temperature for Warranty Tc_w	/	Updated
2018-01-31	E	Description	/	Updated
		General Specifications	Lifetime	Updated
		General Specifications	Operating Case Temperature for Warranty Tc_w	Updated
		Lifetime vs. Case Temperature	/	Updated
2026-03-16	F	Format	/	Updated
		Product Photograph	/	Updated
		CB, KCC	/	Added
		Safety & EMC Compliance	/	Updated
		RoHS Compliance	/	Updated