

Features

- Ultra High Efficiency (Up to 94%)
- Full Power at Wide Output Current Range (Constant Power)
- Thermal Sensing and Protection for LED Module
- 0-10V/PWM/3-Timer-Modes Dimmable
- Dim-to-Off with Standby Power ≤ 0.5 W
- Always-on Auxiliary Power: 12Vdc, 200mA
- Output Lumen Compensation
- Input Surge Protection: DM 6kV, CM 10kV
- All-Around Protection: OVP, SCP, OTP
- IP67 and UL Dry/Damp/Wet Location
- SELV Output
- TYPE HL, for Use in a Class I, Division 2 Hazardous (Classified) Location
- 7 Years Warranty



Description

The EUD-320SxxxDT series is a 320W, constant-current, programmable LED driver that operates from 90-305 Vac input with excellent power factor. Created for many lighting applications including high bay, high mast, aquaculture and sports, etc, it provides a dim-to-off mode with low standby power. The high efficiency of these drivers and compact metal case enables them to run cooler, significantly improving reliability and extending product life. To ensure trouble-free operation, protection is provided against input surge, output over voltage, short circuit, and over temperature.

Models

Adjustable Output Current Range	Full-Power Current Range (1)	Default Output Current	Input Voltage Range(2)	Output Voltage Range	Max. Output Power	Typical Efficiency (3)	Typical Power Factor		Model Number
							120Vac	220Vac	
105-1500mA	1050-1500mA	1400 mA	90~305 Vac/ 127~300 Vdc	107~305Vdc	320 W	94.0%	0.99	0.96	EUD-320S150DT
154-2200mA	1540-2200mA	2100 mA	90~305 Vac/ 127~300 Vdc	73~208Vdc	320 W	93.5%	0.99	0.96	EUD-320S220DT
224-3200mA	2240-3200mA	2800 mA	90~305 Vac/ 127~300 Vdc	50~143Vdc	320 W	93.5%	0.99	0.96	EUD-320S320DT
322-4600mA	3220-4600mA	4200 mA	90~305 Vac/ 127~300 Vdc	35~100Vdc	320 W	93.5%	0.99	0.96	EUD-320S460DT ⁽⁴⁾
469-6700mA	4690-6700mA	6700 mA	90~305 Vac/ 127~300 Vdc	24 ~ 68Vdc	320 W	93.5%	0.99	0.96	EUD-320S670DT ⁽⁴⁾

- Notes:** (1) Output current range with constant power at 320W
 (2) Certified input voltage range: UL, FCC 100-277Vac or 127-300Vdc; otherwise 100-240Vac or 127-250Vdc
 (3) Measured at 100% load and 220Vac input (see below "General Specifications" for details).
 (4) SELV output

I-V Operating Area

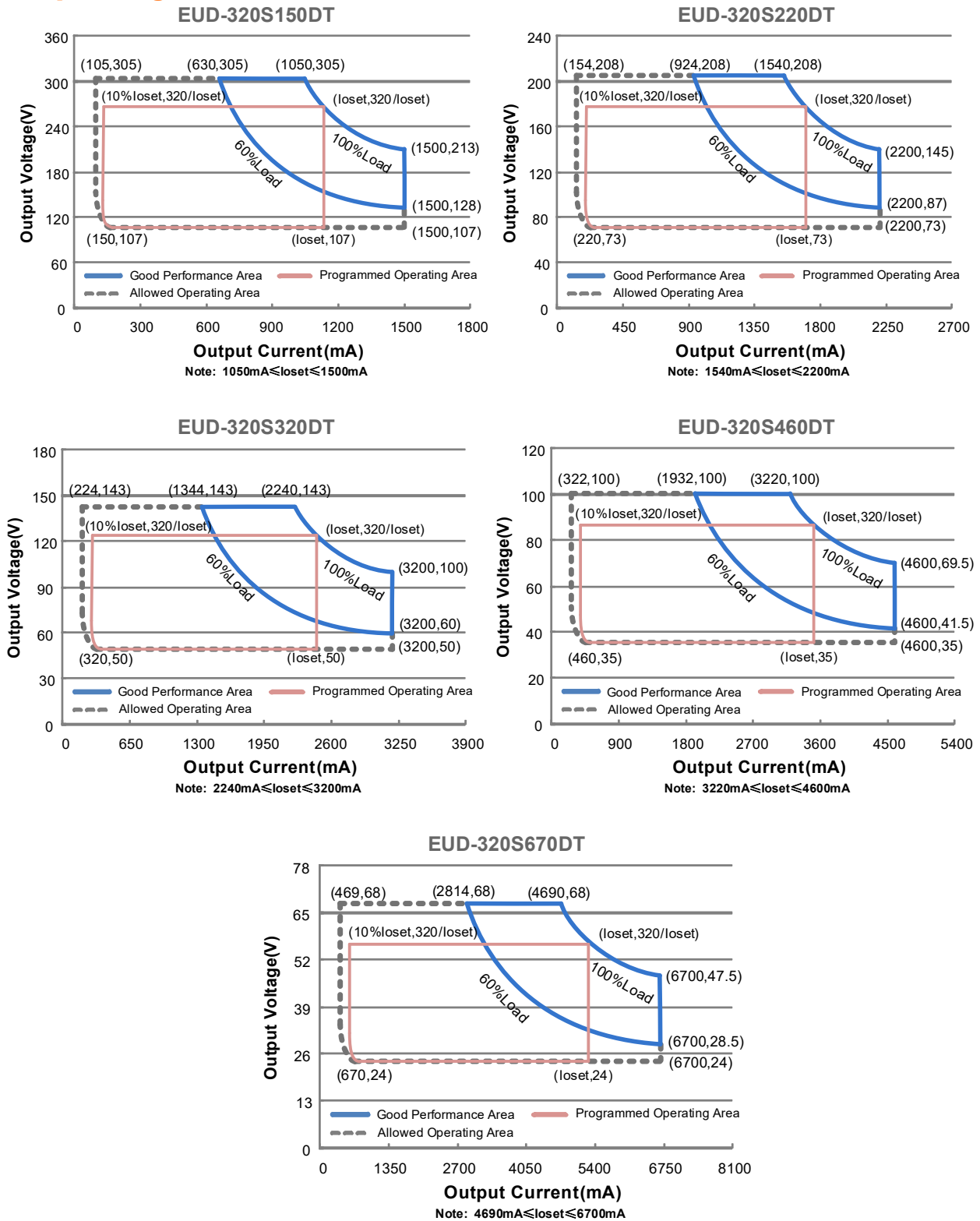

Input Specifications

Parameter	Min.	Typ.	Max.	Notes
Input AC Voltage	90 Vac	-	305 Vac	
Input DC Voltage	127 Vdc	-	300 Vdc	
Input Frequency	47 Hz	-	63 Hz	
Leakage Current	-	-	0.75 MIU	UL 8750; 277Vac/60Hz, grounding effectively
	-	-	0.70 mA	IEC 60598-1; 240Vac/60Hz, grounding effectively
Input AC Current	-	-	3.30 A	Measured at 100% load and 120Vac input.
	-	-	1.80 A	Measured at 100% load and 220Vac input.
Inrush Current(I ² t)	-	-	1.90 A ² s	At 220Vac input, 25°C Cold Start, Duration=3.52 ms, 10%Ipk-10%Ipk. See Inrush Current Waveform for the details.
PF	0.90	-	-	At 100-277Vac, 50-60Hz,60%-100%Load (192-320W)
THD	-	-	20%	
THD	-	-	10%	At 220-240Vac, 50-60Hz,75%-100%Load (240-320W)

Output Specifications

Parameter	Min.	Typ.	Max.	Notes
Output Current Tolerance	-5%loset	-	5%loset	At 100% load condition
Output Current Setting(loset) Range				
EUD-320S150DT	105 mA	-	1500 mA	
EUD-320S220DT	154 mA	-	2200 mA	
EUD-320S320DT	224 mA	-	3200 mA	
EUD-320S460DT	322 mA	-	4600 mA	
EUD-320S670DT	469 mA	-	6700 mA	
Output Current Setting Range with Constant Power				
EUD-320S150DT	1050 mA	-	1500 mA	
EUD-320S220DT	1540 mA	-	2200 mA	
EUD-320S320DT	2240 mA	-	3200 mA	
EUD-320S460DT	3220 mA	-	4600 mA	
EUD-320S670DT	4690 mA	-	6700 mA	
Total Output Current Ripple (pk-pk)	-	5%Iomax	10%Iomax	At 100% load condition, 20 MHz BW
Output Current Ripple at < 200 Hz (pk-pk)	-	2%Iomax	-	At 100% load condition. Only this component of ripple is associated with visible flicker.
Startup Overshoot Current	-	-	10%Iomax	At 100% load condition
No Load Output Voltage				
EUD-320S150DT	-	-	350 V	
EUD-320S220DT	-	-	240 V	
EUD-320S320DT	-	-	160 V	
EUD-320S460DT	-	-	115 V	
EUD-320S670DT	-	-	78 V	

Output Specifications (Continued)

Parameter	Min.	Typ.	Max.	Notes
Line Regulation	-	-	±0.5%	Measured at 100% load
Load Regulation	-	-	±1.5%	
Turn-on Delay Time	-	-	1.0 s	Measured at 120Vac input, 60%-100% Load
	-	-	0.5 s	Measured at 220Vac input, 60%-100% Load
Temperature Coefficient of I _o set	-	0.03%/°C	-	Case temperature = 0°C ~T _c max
12V Auxiliary Output Voltage	10.8 V	12 V	13.2 V	
12V Auxiliary Output Source Current	0 mA	-	200 mA	Return terminal is "Dim-"

General Specifications

Parameter	Min.	Typ.	Max.	Notes
Efficiency at 120 Vac input: EUD-320S150DT				Measured at 100% load and steady-state temperature in 25°C ambient; (Efficiency will be about 2.0% lower if measured immediately after startup.)
I _o =1050mA	89.5%	91.5%	-	
I _o =1500mA	88.0%	90.0%	-	
EUD-320S220DT				
I _o =1540mA	89.5%	91.5%	-	
I _o =2200mA	88.5%	90.5%	-	
EUD-320S320DT				
I _o =2240mA	89.5%	91.5%	-	
I _o =3200mA	87.5%	89.5%	-	
EUD-320S460DT				
I _o =3220mA	89.0%	91.0%	-	
I _o =4600mA	87.5%	89.5%	-	
EUD-320S670DT				
I _o =4690mA	89.0%	91.0%	-	
I _o =6700mA	87.5%	89.5%	-	
Efficiency at 220 Vac input: EUD-320S150DT				Measured at 100% load and steady-state temperature in 25°C ambient; (Efficiency will be about 2.0% lower if measured immediately after startup.)
I _o =1050mA	92.0%	94.0%	-	
I _o =1500mA	90.5%	92.5%	-	
EUD-320S220DT				
I _o =1540mA	91.5%	93.5%	-	
I _o =2200mA	90.5%	92.5%	-	
EUD-320S320DT				
I _o =2240mA	91.5%	93.5%	-	
I _o =3200mA	90.0%	92.0%	-	
EUD-320S460DT				
I _o =3220mA	91.5%	93.5%	-	
I _o =4600mA	90.0%	92.0%	-	
EUD-320S670DT				
I _o =4690mA	91.5%	93.5%	-	
I _o =6700mA	89.5%	91.5%	-	

General Specifications (Continued)

Parameter	Min.	Typ.	Max.	Notes
Efficiency at 277 Vac input: EUD-320S150DT				
Io=1050mA	92.0%	94.0%	-	
Io=1500mA	91.0%	93.0%	-	
EUD-320S220DT				
Io=1540mA	92.0%	94.0%	-	
Io=2200mA	90.5%	92.5%	-	
EUD-320S320DT				
Io=2240mA	92.0%	94.0%	-	
Io=3200mA	90.0%	92.0%	-	
EUD-320S460DT				
Io=3220mA	91.5%	93.5%	-	
Io=4600mA	90.5%	92.5%	-	
EUD-320S670DT				
Io=4690mA	91.5%	93.5%	-	
Io=6700mA	90.0%	92.0%	-	
Standby power	-	-	0.5 W	Measured at 230Vac/50Hz; Dimming off
MTBF	-	237,000 Hours	-	Measured at 220Vac input, 80%Load and 25°C ambient temperature (MIL-HDBK-217F)
Lifetime	-	97,000 Hours	-	Measured at 220Vac input, 80%Load and 70°C case temperature; See lifetime vs. Tc curve for the details
Operating Case Temperature for Safety Tc_s	-40°C	-	+89°C	
Operating Case Temperature for Warranty Tc_w	-40°C	-	+75°C	Case temperature for 7 years warranty. Please see <i>Inventronics Warranty Statement</i> for complete details. Humidity: 10%RH to 95%RH
Storage Temperature	-40°C	-	+85°C	Humidity: 5%RH to 95%RH
Dimensions				With mounting ear
Inches (L × W × H)	8.82 × 3.86 × 1.75			9.88 × 3.86 × 1.75
Millimeters (L × W × H)	224 × 98 × 44.8			251 × 98 × 44.8
Net Weight	-	1875 g	-	

Dimming Specifications

Parameter	Min.	Typ.	Max.	Notes	
Absolute Maximum Voltage on the Vdim (+) Pin	-20 V	-	20 V		
Source Current on Vdim (+)Pin	200 µA	300 µA	450 µA	Vdim(+) = 0 V	
Dimming Output Range	EUD-320S150DT EUD-320S220DT EUD-320S320DT EUD-320S460DT EUD-320S670DT	10%IoSet	-	IoSet	1050mA ≤ IoSet ≤ 1500mA 1540mA ≤ IoSet ≤ 2200mA 2240mA ≤ IoSet ≤ 3200mA 3220mA ≤ IoSet ≤ 4600mA 4690mA ≤ IoSet ≤ 6700mA
	EUD-320S150DT EUD-320S220DT EUD-320S320DT EUD-320S460DT EUD-320S670DT	105 mA 154 mA 224 mA 322 mA 469 mA	-	IoSet	105mA ≤ IoSet < 1050mA 154mA ≤ IoSet < 1540mA 224mA ≤ IoSet < 2240mA 322mA ≤ IoSet < 3220mA 469mA ≤ IoSet < 4690mA

Dimming Specifications (Continued)

Parameter	Min.	Typ.	Max.	Notes
Recommended Dimming Input Range	0 V	-	10 V	Default 0-10V dimming mode.
Dim off Voltage	0.35 V	0.5 V	0.65 V	
Dim on Voltage	0.55 V	0.7 V	0.85 V	
Hysteresis	-	0.2 V	-	
PWM_in High Level	3 V	-	10 V	Dimming mode set to PWM in Inventronics Programing Software.
PWM_in Low Level	-0.3 V	-	0.6 V	
PWM_in Frequency Range	200 Hz	-	3 KHz	
PWM_in Duty Cycle	1%	-	99%	
PWM Dimming off (Positive Logic)	3%	5%	8%	
PWM Dimming on (Positive Logic)	5%	7%	10%	
PWM Dimming off (Negative Logic)	92%	95%	97%	
PWM Dimming on (Negative Logic)	90%	93%	95%	
Hysteresis	-	2%	-	

Safety & EMC Compliance

Safety Category	Standard
UL/CUL	UL 8750,CAN/CSA-C22.2 No. 250.13
CE	EN 61347-1, EN 61347-2-13
CB	IEC 61347-1, IEC 61347-2-13
EMI Standards	Notes
EN IEC 55015/KS C 9815 ⁽¹⁾	Conducted emission Test & Radiated emission Test
EN IEC 61000-3-2	Harmonic current emissions Class C
EN 61000-3-3	Voltage Fluctuations & Flicker
FCC Part 15 ⁽¹⁾	ANSI C63.4 Class B
	This device complies with Part 15 of the FCC Rules. Operation is subject to the following two conditions: [1] this device may not cause harmful interference, and [2] this device must accept any interference received, including interference that may cause undesired Operation.
EMS Standards	Notes
EN 61000-4-2	Electrostatic Discharge(ESD): 8kV air discharge, 4kV contact discharge
EN 61000-4-3	Radio-Frequency Electromagnetic Field Susceptibility Test-RS

Safety & EMC Compliance (Continued)

EMS Standards	Notes
EN 61000-4-4	Electrical Fast Transient/Burst-EFT
EN 61000-4-5	Surge Immunity Test: AC Power Line: Differential Mode 6kV, Common Mode 10kV ⁽²⁾
EN 61000-4-6	Conducted Radio Frequency Disturbances test-CS
EN 61000-4-8	Power Frequency Magnetic Field Test
EN 61000-4-11	Voltage Dips
EN 61547/KS C 9547	Electromagnetic Immunity Requirements Applies To Lighting Equipment

Note: (1) This LED driver meets the EMI specifications above, but EMI performance of a luminaire that contains it depends also on the other devices connected to the driver and on the fixture itself.

(2) To perform electric strength (hi-pot) testing, the “GDT ground disconnect” (nut and metal lock sheet) on the driver end-cap should be removed temporarily to prevent the internal gas discharge tube from conducting (as allowed by IEC 60598-1 Clause 10.2). After testing is completed, these items must be reinstalled to restore line-to-earth surge protection and secure the end cap.

Derating

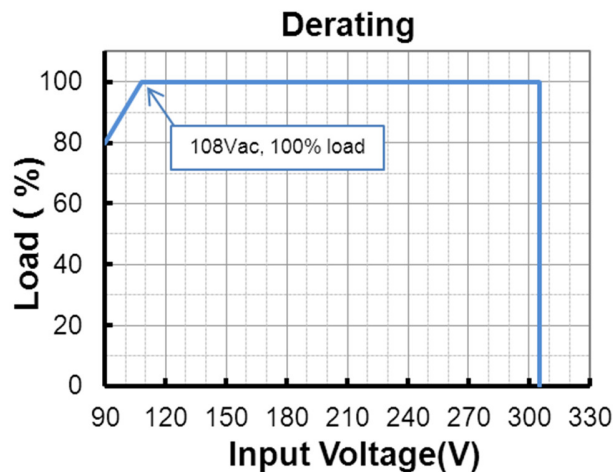

Lifetime vs. Case Temperature

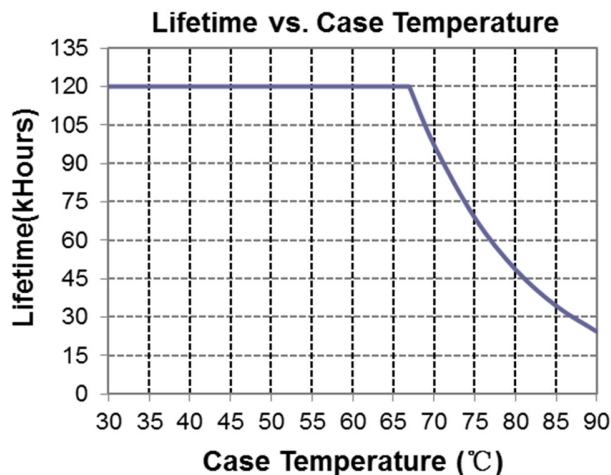

Inrush Current Waveform

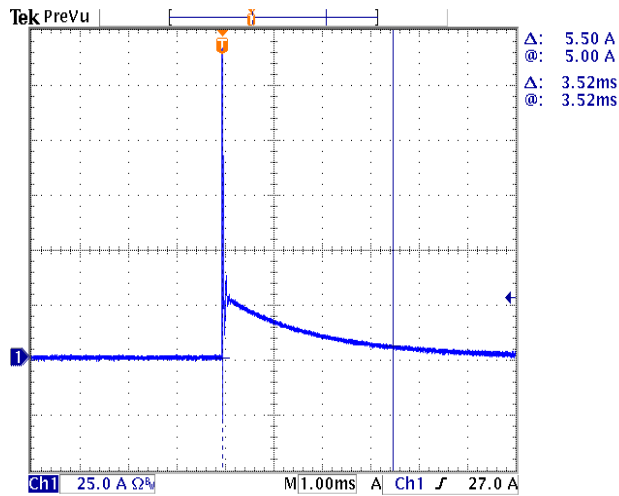

Efficiency vs. Load

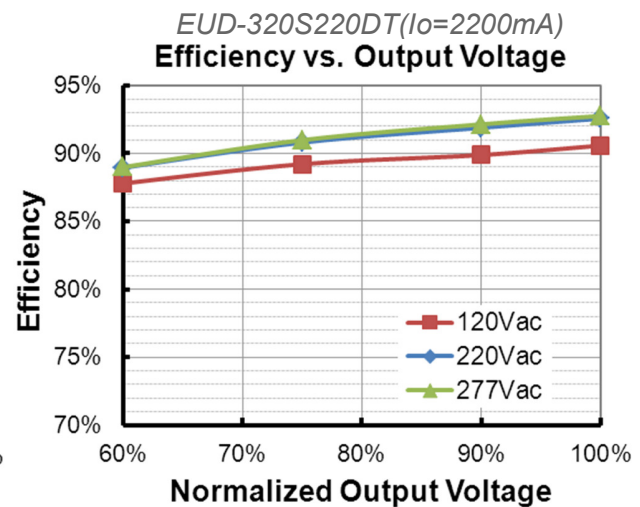
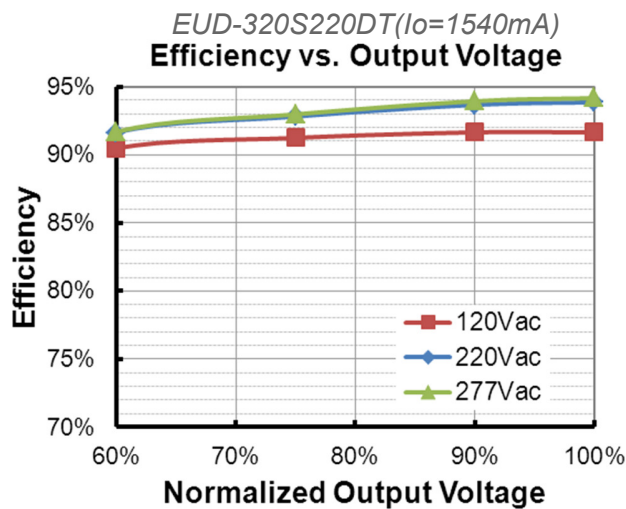
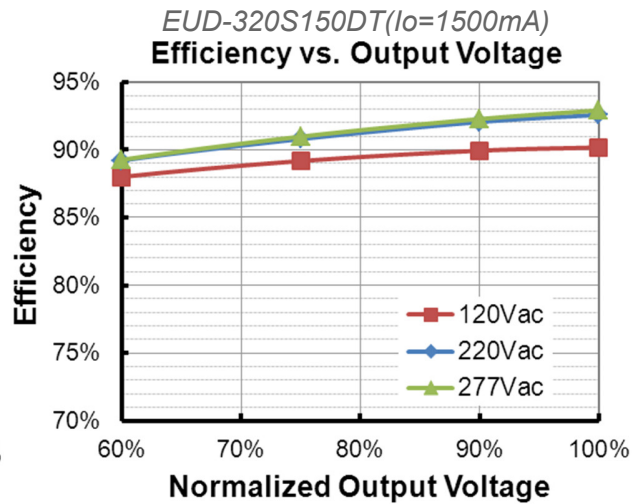
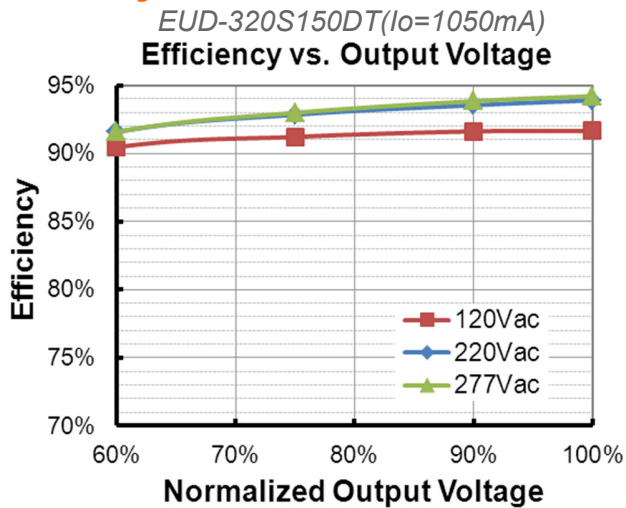

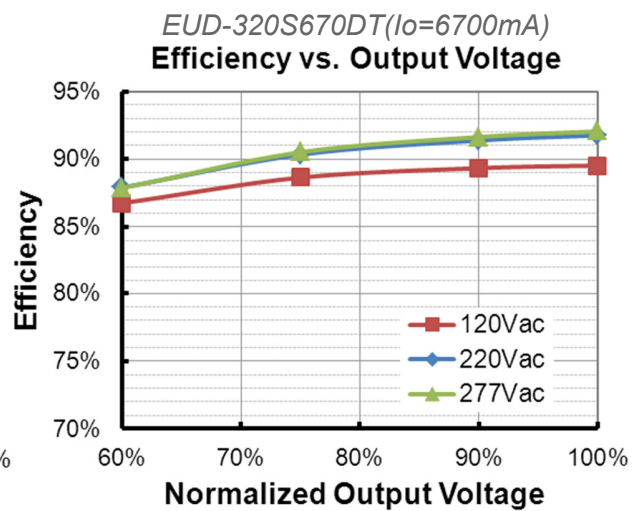
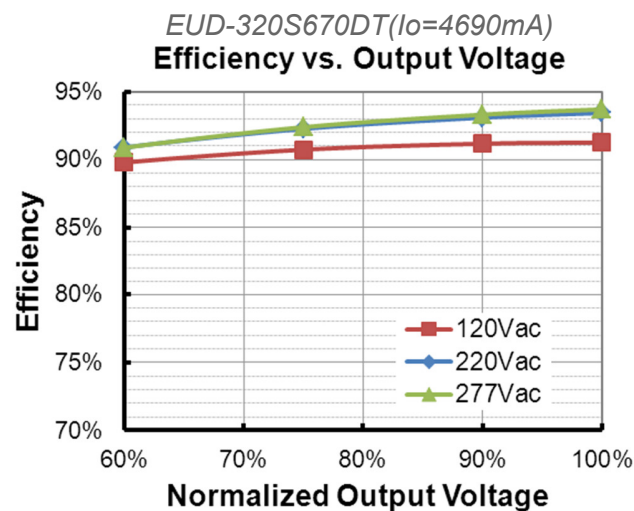
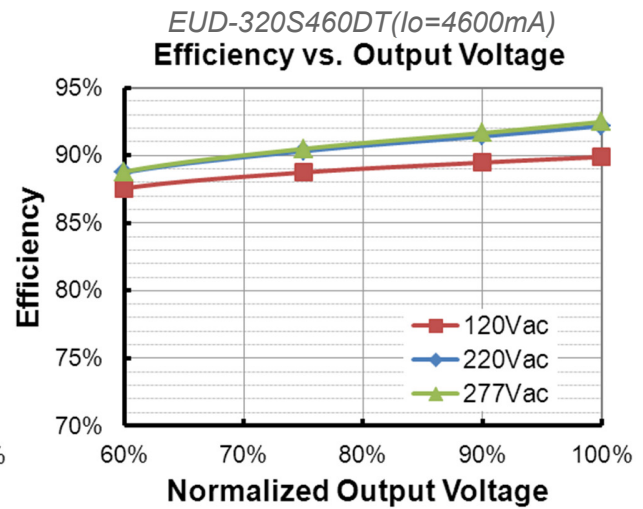
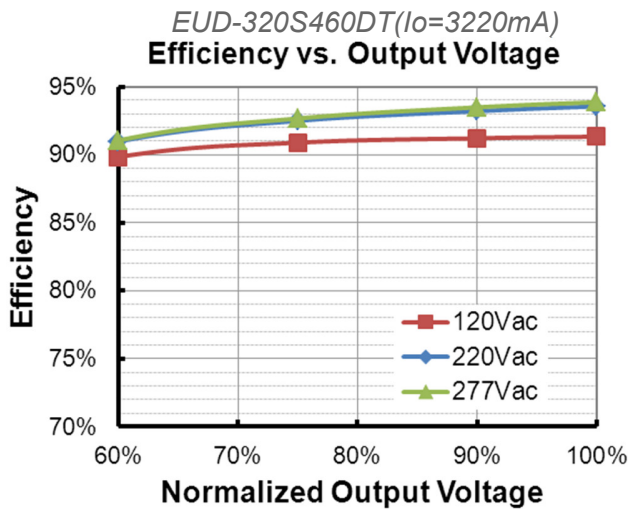
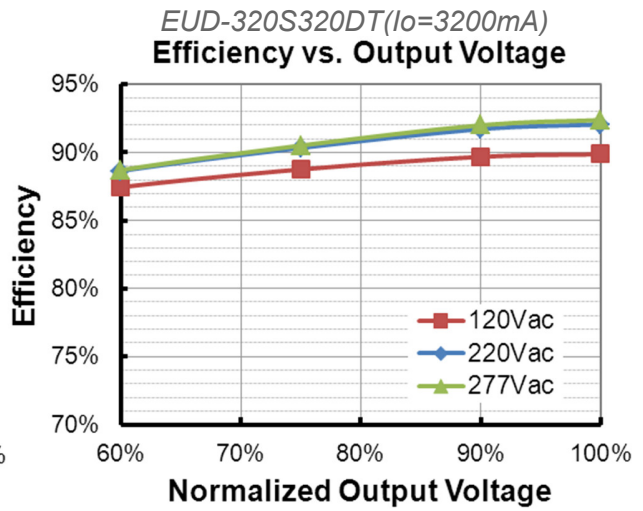
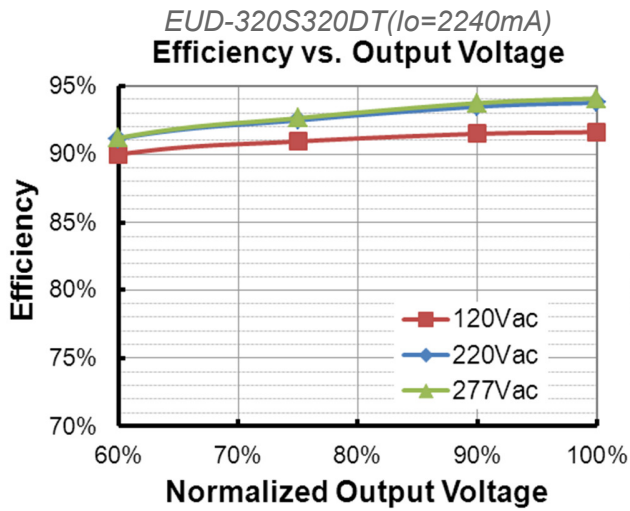

Power Factor

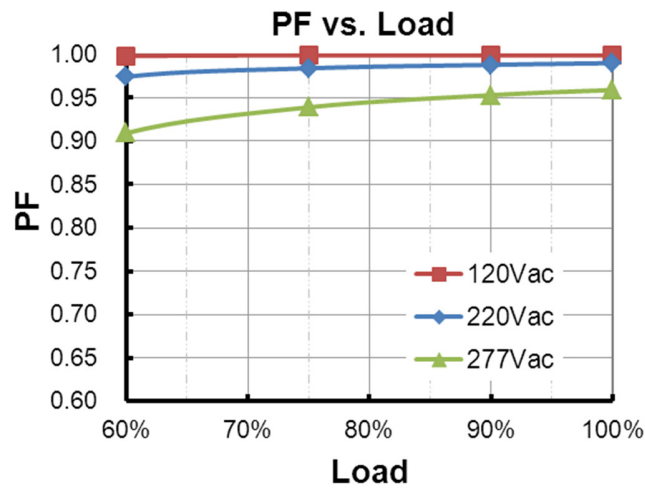

Total Harmonic Distortion

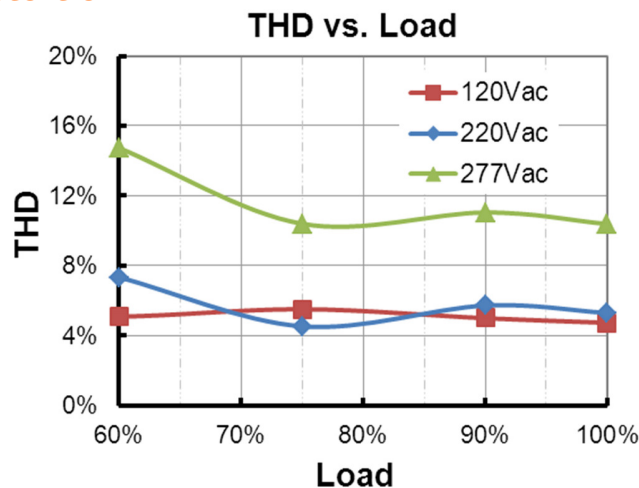

Protection Functions

Parameter		Min.	Typ.	Max.	Notes
External Thermal Protection NTC	R1	-	7.81 kOhm	-	When R_NTC falls below R1, External Thermal Protection is triggered, reducing output current until R2 is reached.
	R2	-	4.16 kOhm	-	When R_NTC is less than R2, output current is reduced to the programmed "Protection Current Floor."
	Protection Current Setting Range	10%loset	60%loset	100%loset	10%loset > lomin (default setting is 60%)
		lomin	60%loset	100%loset	10%loset ≤ lomin (default setting is 60%)
Over Temperature Protection	Decreases output current, returning to normal after over temperature is removed.				
Short Circuit Protection	Auto Recovery. No damage will occur when any output is short circuited. The output shall return to normal when the fault condition is removed.				
Over Voltage Protection	Limits output voltage at no load and in case the normal voltage limit fails.				

Dimming

● 0-10V Dimming

The recommended implementation of the dimming control is provided below.

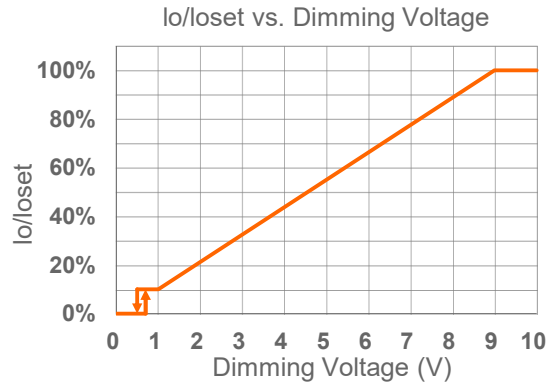
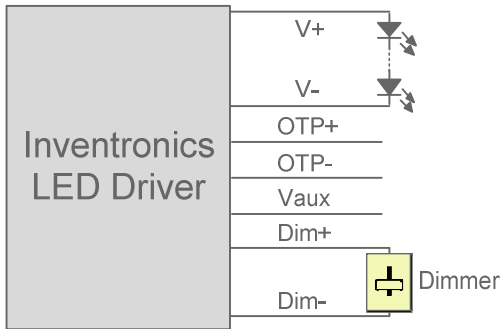

Implementation 1: DC Input

Notes:

1. Do NOT connect Dim- to the output V- or V+, otherwise the driver will not work properly.
2. The dimmer can also be replaced by an active 0-10V voltage source signal or passive components like zener.

● PWM Dimming

The recommended implementation of the dimming control is provided below.

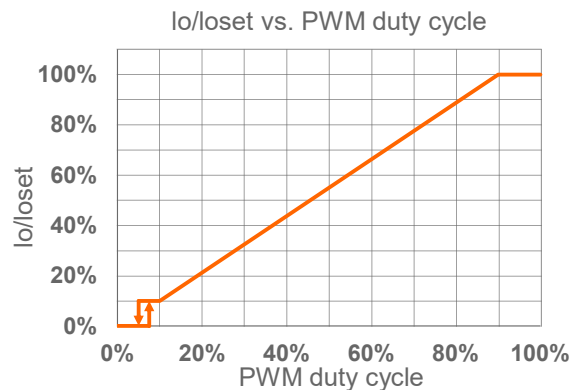
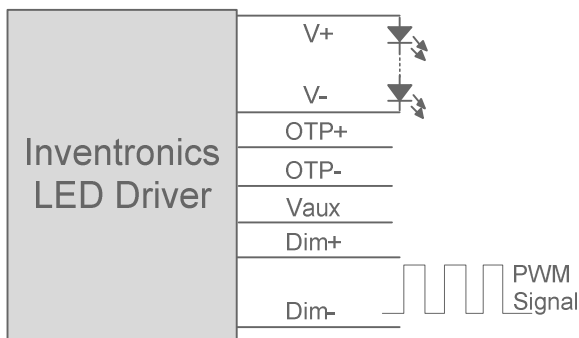

Implementation 2: Positive logic

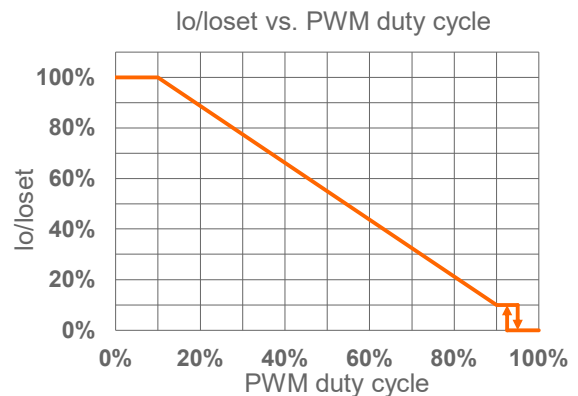
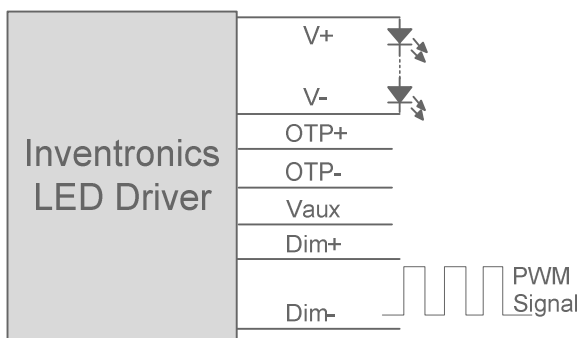

Implementation 3: Negative logic

Notes:

1. Do NOT connect Dim- to the output V- or V+, otherwise the driver will not work properly.
2. When PWM negative logic dimming mode and Dim+ is open, the driver will dim to off and be standby.

● **Time Dimming**

Time dimming control includes 3 kinds of modes, they are Self Adapting-Midnight, Self Adapting-Percentage and Traditional Timer.

- **Self Adapting-Midnight:** Automatically adjusts the dimming curve based on the on-time of past two days (if difference <15 minutes), assuming that the center point of the dimming curve is midnight local time.
- **Self Adapting-Percentage:** Automatically adjusts the on-time of each step by a constant percentage = (actual on-time for the past 2 days if difference <15 min) / (programmed on-time from the dimming curve).
- **Traditional Timer:** Follows the programmed timing curve after power on with no changes.

● **Output Lumen Compensation**

Output Lumen Compensation (OLC) may be used to maintain constant light output over the life of the LEDs by driving them at a reduced current when new, then gradually increasing the drive current over time to counteract LED lumen degradation.

Programming Connection Diagram

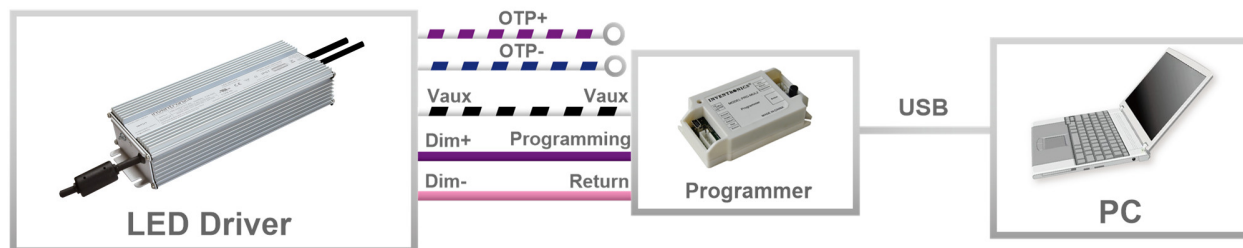

Note: The driver does not need to be powered on during the programming process.

- Please refer to [PRG-MUL2 \(Programmer\) datasheet](#) for details.

Mechanical Outline

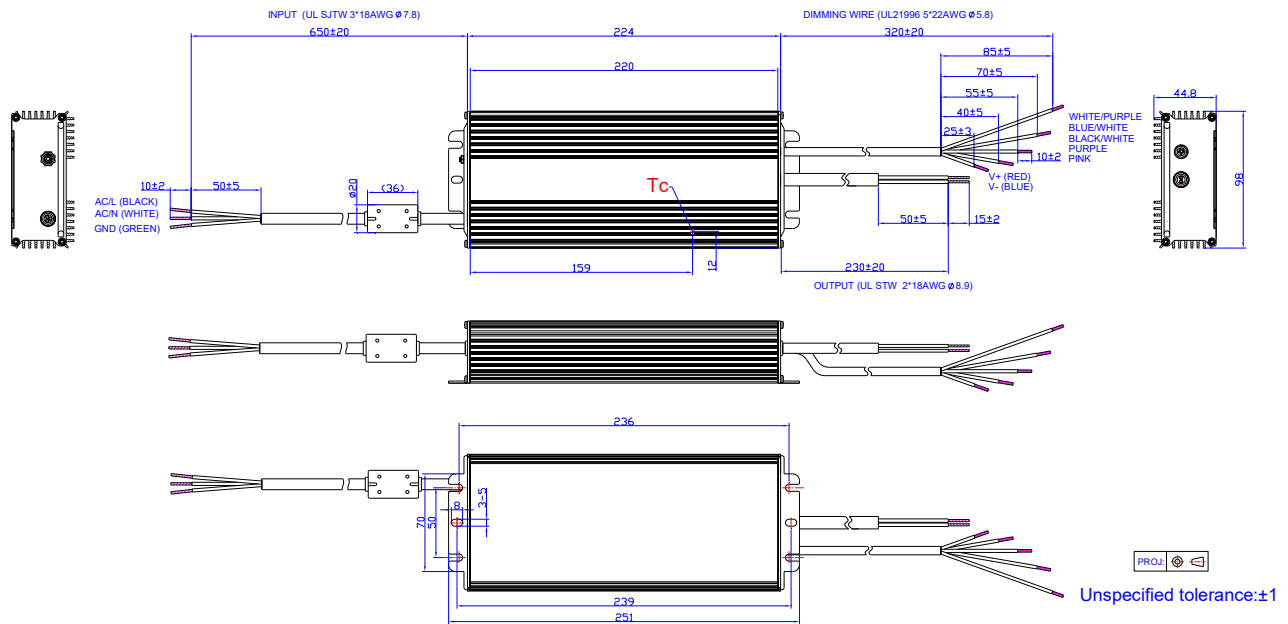

RoHS Compliance

Our products comply with reference to RoHS Directive (EU) 2015/863 amending 2011/65/EU, calling for the elimination of lead and other hazardous substances from electronic products.

Revision History

Change Date	Rev.	Description of Change		
		Item	From	To
2016-03-28	A	Datasheets Release	/	/
2017-07-31	B	Features	/	Updated
		Models	/	Updated
		Input Specifications	PF/THD	Updated
		Output Specifications	Temperature Coefficient of loset	Updated
		General Specifications	Dimensions	Updated
		Safety & EMC Compliance	/	Updated
		Mechanical Outline	/	Updated
2017-10-25	C	Features	Always-on Auxiliary Power	Added
		Features	7 Years Warranty	Added
		General Specifications	Operating Case Temperature for Warranty Tc_w	Updated
2018-01-22	D	Description	/	Updated
		General Specifications	Lifetime	Updated
		Operating Case Temperature for Warranty Tc_w	+70°C	+75°C
		Lifetime vs. Case Temperature	/	Updated
2019-10-16	E	KCC Logo	/	Added
		Features	Timer Dimmable (3 Timer Modes)	3-Timer-Modes Dimmable
		Features	6kV line-line, 10kV line-earth	DM 6kV, CM 10kV
		Features	Waterproof (IP67)	IP67
		Safety & EMC Compliance	EN 55015 ⁽¹⁾	EN 55015/KN 15 ⁽¹⁾
		Safety & EMC Compliance	EN 61000-4-5	Updated
		Mechanical Outline	/	Updated
		RoHS Compliance	/	Updated

Revision History (Continued)

Change Date	Rev.	Description of Change		
		Item	From	To
2022-03-10	F	Product Photograph	/	Updated
		ENEC/CB/TUV logo	/	Added
		General Specifications	Humidity	Updated
		General Specifications	Dimensions	Updated
		Safety &EMC Compliance	ENEC/CB/TUV	Added
		Dimming	/	Updated
		Programming Connection Diagram	/	Updated
		Mechanical Outline	/	Updated
2024-05-08	G	Product Photograph	/	Updated
		ENEC/TUV logo	/	Deleted
		Safety &EMC Compliance	/	Updated
		Programming Connection Diagram	/	Updated
2026-03-17	H	Format	/	Updated
		Product Photograph	/	Updated