

Features

- Ultra High Efficiency (Up to 93.5%)
- Ultra High Input Voltage (249~528Vac)
- Constant Voltage Output
- Input Surge Protection: DM 6kV, CM 10kV
- All-Around Protection: OCP, OVP, SCP, OTP
- IP67 and UL Dry / Damp / Wet Location
- UL Class P & SELV Output
- TYPE HL, for Use in a Class I, Division 2 Hazardous (Classified) Location
- 5 Years Warranty



Description

The *ESV-320SxxxST* series is a 320W, constant-voltage IP67 LED driver that operates from 249~528 Vac input with excellent power factor. It is created for many lighting applications including horticulture lighting, architectural, and decorative. The high efficiency of these drivers enables them to run cooler, significantly improving reliability and extending product life. To ensure trouble-free operation, protection is provided against input surge, over current, output over voltage, short circuit, and over temperature.

Models

Output Voltage	Input Voltage Range(1)	Output Current Range	Max. Output Power	Typical Efficiency (2)	Typical Power Factor		Model Number(3)
					277Vac	480Vac	
24 Vdc	249~528Vac 352~500Vdc	0 ~ 13.4 A	320 W	92.5%	0.95	0.90	ESV-320S024ST
36 Vdc	249~528Vac 352~500Vdc	0 ~ 8.9 A	320 W	92.5%	0.95	0.90	ESV-320S036ST
48 Vdc	249~528Vac 352~500Vdc	0 ~ 6.7 A	320 W	93.0%	0.95	0.90	ESV-320S048ST
54 Vdc	249~528Vac 352~500Vdc	0 ~ 6.0 A	320 W	93.5%	0.95	0.90	ESV-320S054ST

Notes: (1) Certified voltage range: 277-480Vac or 352-500Vdc.

(2) Measured at 25°C, 100% load and 480 Vac input.

(3) SELV output.

Input Specifications

Parameter	Min.	Typ.	Max.	Notes
Input AC Voltage	249 Vac	-	528 Vac	
Input DC Voltage	352 Vdc	-	500 Vdc	
Input Frequency	47 Hz	-	63 Hz	

Input Specifications (Continued)

Parameter	Min.	Typ.	Max.	Notes
Leakage Current	-	-	0.75 MIU	UL 8750; 480Vac/60Hz
	-	-	0.7 mA	IEC 60598-1; 480Vac/60Hz
Input AC Current	-	-	1.4 A	Measured at 100% load and 277 Vac input.
	-	-	0.81 A	Measured at 100% load and 480 Vac input.
Inrush Current(I ² t)	-	-	8.93 A ² s	At 480Vac input, 25°C Cold Start, Duration=616µs, 10%Ipk-10%Ipk. See Inrush Current Waveform for the details.
PF	0.90	-	-	At 277-480Vac, 50-60Hz, 60%-100% load (192-320W)
THD	-	-	20%	

Output Specifications

Parameter	Min.	Typ.	Max.	Notes
Output Voltage Tolerance	-2.5%	-	2.5%	
Output Voltage Ripple (pk-pk)	-	-	2%Vo	At 0% - 100% load condition. Measured by 20 MHz bandwidth oscilloscope and the output paralleled a 0.1 µF ceramic capacitor and a 10 µF electrolytic capacitor.
Output Voltage Overshoot /Undershoot	-	-	5%Vo	
Line Regulation	-	-	±0.5%	Measured at 100% load
Load Regulation	-	-	±1.0%	
Turn-on Delay Time	-	-	0.5 s	Measured at 277Vac input, 60%-100% load
	-	-	0.5 s	Measured at 480Vac input, 60%-100% load
Load Dynamic Response	Output Deviation	-	5%Vo	R/S: 1 A/us Load: 10% ~ 100%load.
	Settling Time	-	10 ms	
Temperature Coefficient	-	0.03%/°C	-	Case temperature = 0°C~Tc max

General Specifications

Parameter	Min.	Typ.	Max.	Notes
Efficiency at 277Vac input:				Measured at 100% load and steady-state temperature in 25°C ambient; (Efficiency will be about 2.0% lower if measured immediately after startup.)
ESV-320S024ST	89.0%	91.0%	-	
ESV-320S036ST	89.5%	91.5%	-	
ESV-320S048ST	90.0%	92.0%	-	
ESV-320S054ST	90.0%	92.0%	-	

General Specifications (Continued)

Parameter	Min.	Typ.	Max.	Notes
Efficiency at 347Vac input: ESV-320S024ST ESV-320S036ST ESV-320S048ST ESV-320S054ST	90.0% 90.0% 90.5% 91.0%	92.0% 92.0% 92.5% 93.0%	- - - -	Measured at 100% load and steady-state temperature in 25°C ambient; (Efficiency will be about 2.0% lower if measured immediately after startup.)
Efficiency at 480Vac input: ESV-320S024ST ESV-320S036ST ESV-320S048ST ESV-320S054ST	90.5% 90.5% 91.0% 91.5%	92.5% 92.5% 93.0% 93.5%	- - - -	Measured at 100% load and steady-state temperature in 25°C ambient; (Efficiency will be about 2.0% lower if measured immediately after startup.)
MTBF	-	230,000 Hours	-	Measured at 480Vac input, 80%load and 25°C ambient temperature (MIL-HDBK-217F)
Lifetime	-	93,000 Hours	-	Measured at 480Vac input, 80%load and 70°C case temperature; See lifetime vs. Tc curve for the details
Operating Case Temperature for Safety Tc_s	-40°C	-	+90°C	
Operating Case Temperature for Warranty Tc_w	-40°C	-	+70°C	Case temperature for 5 years warranty. Humidity: 10% RH to 100% RH.
Storage Temperature	-40°C	-	+85°C	Humidity: 5%RH to 100%RH
Dimensions Inches (L × W × H) Millimeters (L × W × H)	8.82 × 3.86 × 1.76 224 × 98 × 44.8			With mounting ear 9.88 × 3.86 × 1.76 251 × 98 × 44.8
Net Weight	-	1815 g	-	

Safety & EMC Compliance

Safety Category	Standard
UL/CUL	UL 8750, CAN/CSA-C22.2 No. 250.13
CE	EN 61347-1, EN 61347-2-13
EMI Standards	Notes
EN IEC 55015 ⁽¹⁾	Conducted emission Test & Radiated emission Test
EN IEC 61000-3-2	Harmonic current emissions
EN 61000-3-3	Voltage fluctuations & flicker
FCC Part15 ⁽¹⁾	ANSI C63.4 Class B
	This device complies with Part 15 of the FCC Rules. Operation is subject to the following two conditions: [1] this device may not cause harmful interference, and [2] this device must accept any interference received, including interference that may cause undesired operation.

Safety & EMC Compliance (Continued)

EMS Standards	Notes
EN 61000-4-2	Electrostatic Discharge (ESD): 8 kV air discharge, 4 kV contact discharge
EN 61000-4-3	Radio-Frequency Electromagnetic Field Susceptibility Test-RS
EN 61000-4-4	Electrical Fast Transient / Burst-EFT
EN 61000-4-5	Surge Immunity Test: AC Power Line: Differential Mode 6 kV, Common Mode 10 kV ⁽²⁾
EN 61000-4-6	Conducted Radio Frequency Disturbances Test-CS
EN 61000-4-8	Power Frequency Magnetic Field Test
EN 61000-4-11	Voltage Dips
EN IEC 61547	Electromagnetic Immunity Requirements Applies To Lighting Equipment

Notes: (1) This LED driver meets the EMI specifications above, but EMI performance of a luminaire that contains it depends also on the other devices connected to the driver and on the fixture itself.

(2) To perform electric strength (hi-pot) testing, the “GDT ground disconnect” (nut and metal lock sheet) on the driver end-cap should be removed temporarily to prevent the internal gas discharge tube from conducting (as allowed by IEC 60598-1 Clause 10.2). After testing is completed, these items must be reinstalled to restore line-to-earth surge protection and secure the end cap.

Lifetime vs. Case Temperature Curve

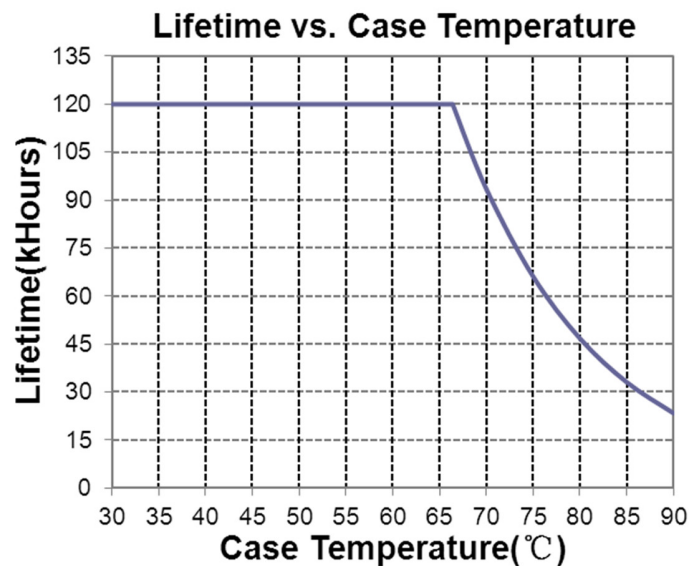

Inrush Current Waveform

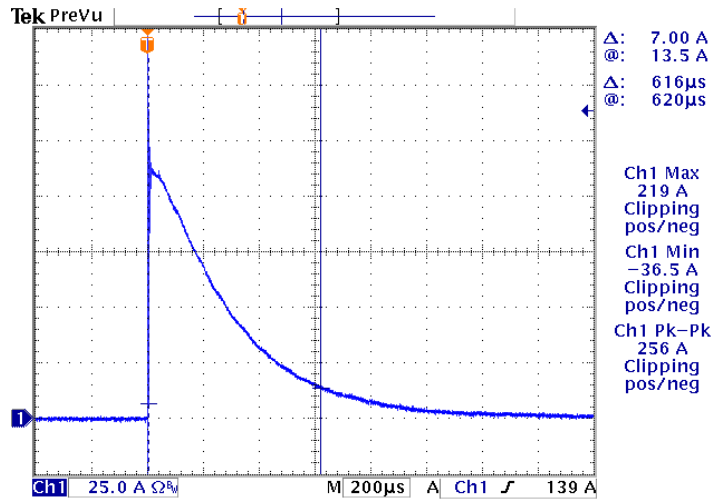

Efficiency vs. Load

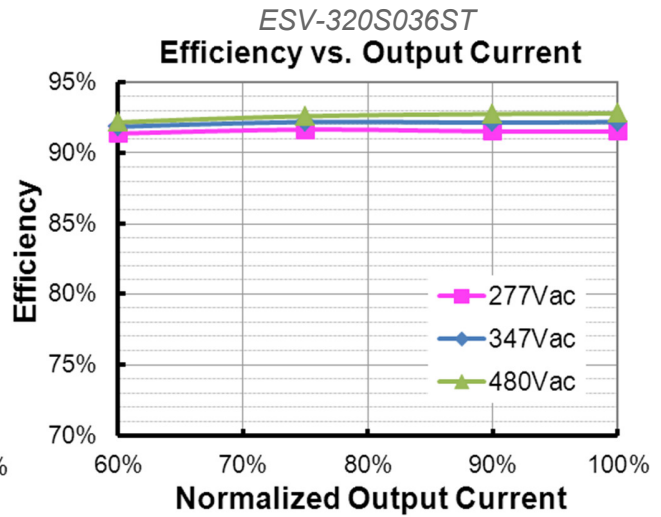
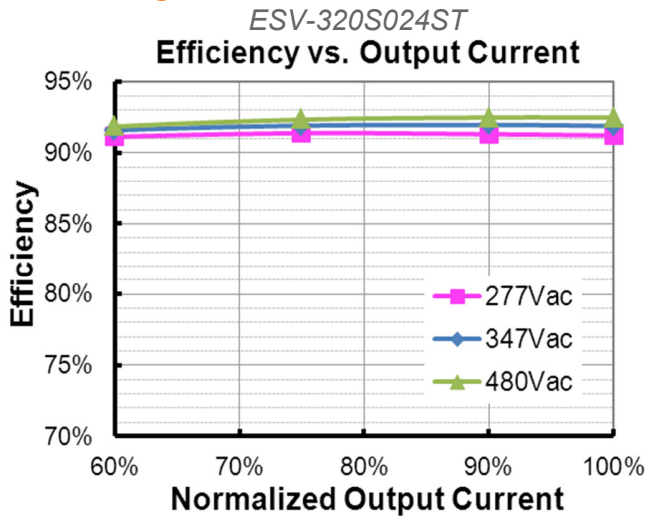

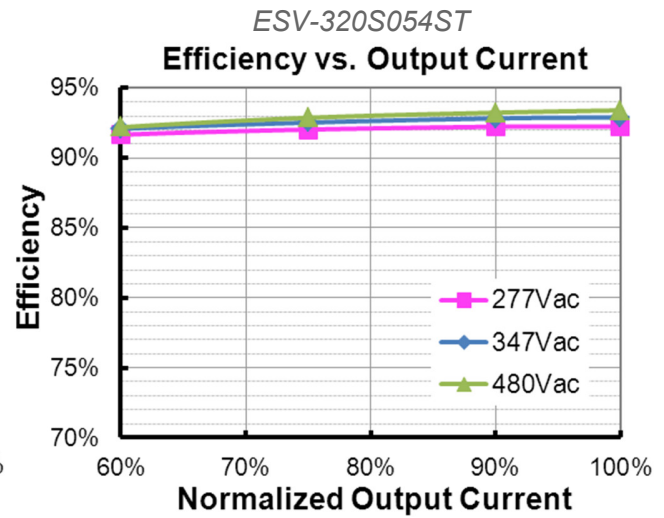
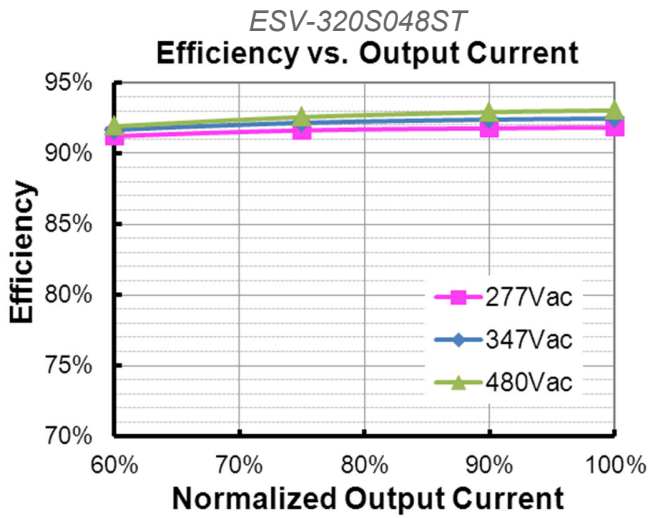

Power Factor Characteristics

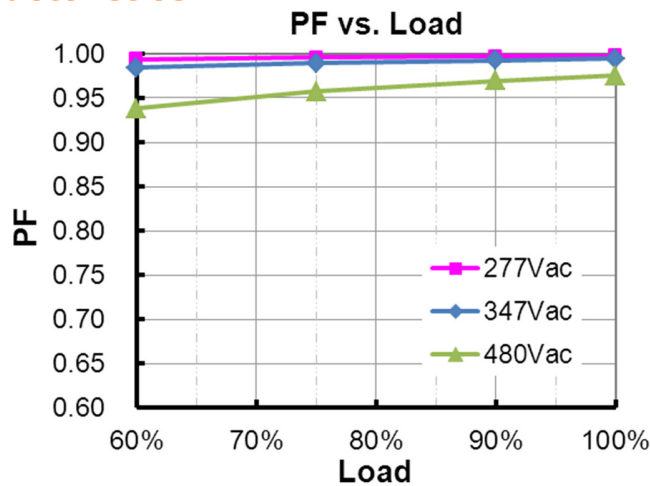

Total Harmonic Distortion

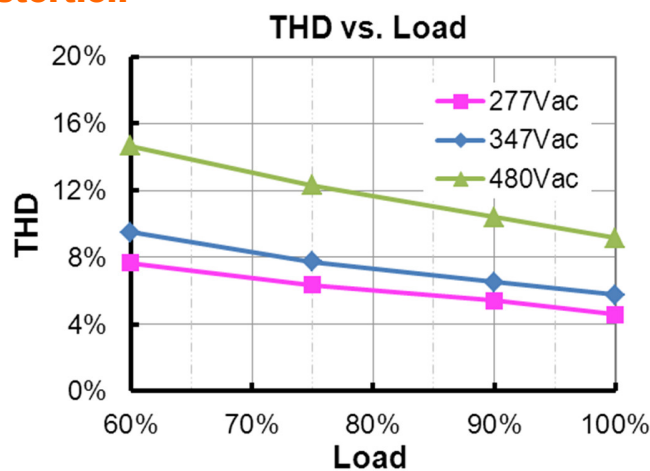

Protection Functions

Parameter	Notes
Over Current Protection	Auto Recovery. The driver shall be self-recovery when the fault condition is removed.
Over Voltage Protection	Limits output voltage at no load and in case the normal voltage limit fails.
Short Circuit Protection	Auto Recovery. No damage will occur when any output is short circuited. The output shall return to normal when the fault condition is removed.
Over Temperature Protection	Auto Recovery. Returning to normal after over temperature is removed.

Mechanical Outline

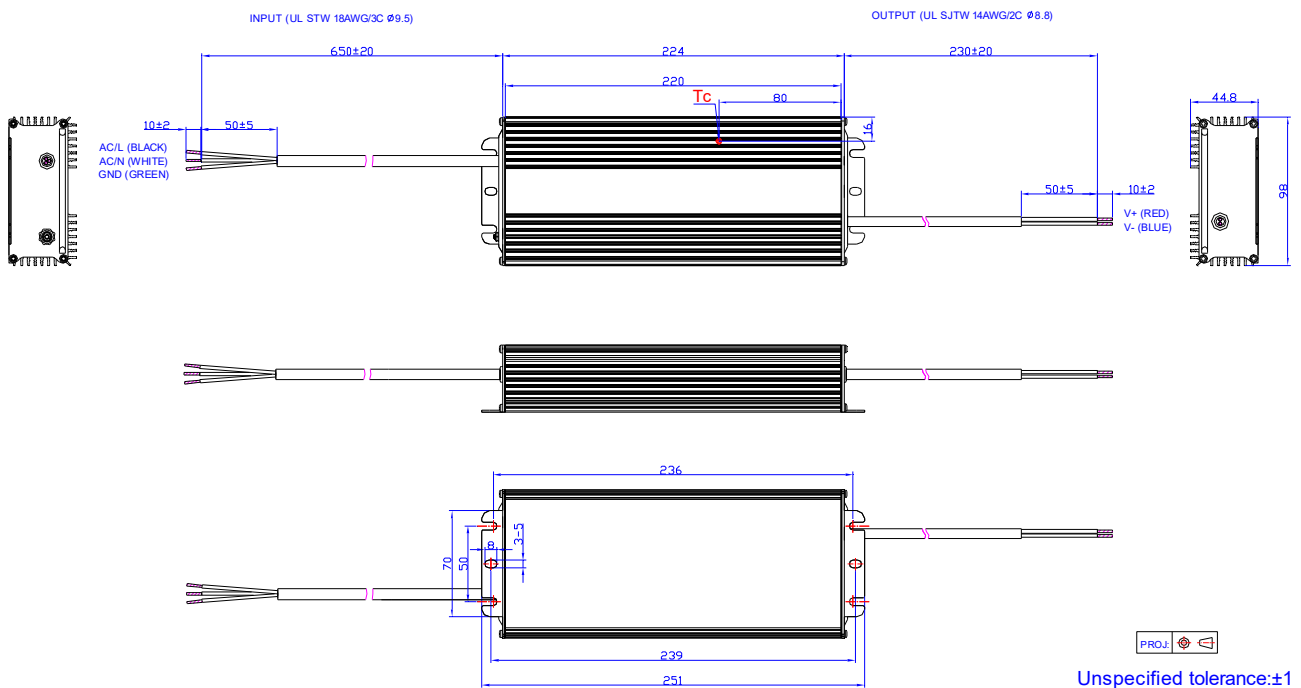

RoHS Compliance

Our products comply with reference to RoHS Directive (EU) 2015/863 amending 2011/65/EU, calling for the elimination of lead and other hazardous substances from electronic products.

Revision History

Change Date	Rev.	Description of Change		
		Item	From	To
2018-11-30	A	Datasheet Release	/	/
2026-04-15	B	Format	/	Updated
		Product Photograph	/	Updated
		Safety &EMC Compliance	/	Updated
		RoHS Compliance	/	Updated